

# **Stratus<sup>®</sup> ftServer<sup>®</sup> 27x0, 47x0, and 64x0 Systems: Site Planning Guide**

Stratus Technologies  
R666-04

---

# Notice

The information contained in this document is subject to change without notice.

UNLESS EXPRESSLY SET FORTH IN A WRITTEN AGREEMENT SIGNED BY AN AUTHORIZED REPRESENTATIVE OF STRATUS TECHNOLOGIES, STRATUS MAKES NO WARRANTY OR REPRESENTATION OF ANY KIND WITH RESPECT TO THE INFORMATION CONTAINED HEREIN, INCLUDING WARRANTY OF MERCHANTABILITY AND FITNESS FOR A PURPOSE. Stratus Technologies assumes no responsibility or obligation of any kind for any errors contained herein or in connection with the furnishing, performance, or use of this document.

Software described in Stratus documents (a) is the property of Stratus Technologies Bermuda, Ltd. or the third party, (b) is furnished only under license, and (c) may be copied or used only as expressly permitted under the terms of the license.

Stratus documentation describes all supported features of the user interfaces and the application programming interfaces (API) developed by Stratus. Any undocumented features of these interfaces are intended solely for use by Stratus personnel and are subject to change without warning.

This document is protected by copyright. All rights are reserved. Stratus Technologies grants you limited permission to download and print a reasonable number of copies of this document (or any portions thereof), without charge, for your internal use only, provided you retain all copyright notices and other restrictive legends and/or notices appearing in the copied document.

Stratus, the Stratus logo, ftServer, and the ftServer logo are registered trademarks of Stratus Technologies Bermuda, Ltd.

The Stratus Technologies logo, the Stratus 24 x 7 logo, ActiveService, ftScalable, Automated Uptime, and Active Upgrade are trademarks of Stratus Technologies Bermuda, Ltd.

VMware, vSphere, ESX, ESXi, vCenter Server, and vMotion are registered trademarks or trademarks of VMware, Inc. in the United States and/or other jurisdictions. QLogic, the QLogic logo SANbox, InfiniPath and SANblade are trademarks or registered trademarks of QLogic Corporation.

All other trademarks are the property of their respective owners.

Manual Name: *Stratus ftServer 27x0, 47x0, and 64x0 Systems: Site Planning Guide*

Part Number: R666

Revision Number: 04

Software Release Number: Automated Uptime Layer for Windows-based ftServer Systems, Release 9.0.0

Automated Uptime Layer for VMware vSphere-based ftServer Systems, Release 5.1.0

Publication Date: April 2014

Stratus Technologies, Inc.

111 Powdermill Road

Maynard, Massachusetts 01754-3409

© 2014 Stratus Technologies Bermuda, Ltd. All rights reserved.

---

# Contents

---

|                |    |
|----------------|----|
| <b>Preface</b> | ix |
|----------------|----|

---

|   |      |
|---|------|
| <b>1. Site Planning for ftServer 27x0, 47x0, and 64x0 Systems</b> | 1-1  |
| Site Planning Overview  | 1-1  |
| The Stratus ActiveService Network                                 | 1-3  |
| Site Planning Checklist   | 1-3  |
| System Documentation  | 1-7  |
| Safety Notices  | 1-10 |
| Consignes de sécurité   | 1-13 |
| Safety Notices (Traditional Chinese)                              | 1-17 |

---

|   |      |
|---|------|
| <b>2. Electrical Power Planning</b>                 | 2-1  |
| Redundant Power Sources                             | 2-1  |
| AC Power and HVAC Service Requirements              | 2-2  |
| AC Power Outlet Requirements                        | 2-4  |
| Connecting a System Directly to Separate AC Sources | 2-6  |
| Selecting a UPS Unit for ftServer Systems           | 2-9  |
| Communicating with a UPS over a Network             | 2-9  |
| Connecting a System Directly to a UPS               | 2-10 |
| Power Cord Summary                                  | 2-11 |
| Power Cords for ftServer Systems and Peripheral     |      |
| Components  | 2-11 |
| PDU Power Cords                                     | 2-13 |
| Grounding Requirements                              | 2-14 |

---

|                          |     |
|--------------------------|-----|
| <b>3. Space Planning</b> | 3-1 |
| Room Requirements        | 3-1 |
| Planning for Cables      | 3-3 |

---

|  |     |
|--|-----|
| <b>4. Communications Line Planning</b>               | 4-1 |
| Supported Host Bus Adapters                          | 4-2 |
| Connections from Storage Systems to ftServer Systems | 4-2 |
| Fibre Channel Connections                            | 4-2 |
| iSCSI Connections                                    | 4-4 |
| Ethernet Cables                                      | 4-5 |
| Category-6/Category-6A Cables                        | 4-7 |
| Telephone Line Connections                           | 4-8 |
| Modem Requirements for Brazil                        | 4-9 |
| Modem Requirements for Belarus                       | 4-9 |
| Modem Requirements for Kazakhstan                    | 4-9 |

---

|                                       |     |
|---------------------------------------|-----|
| <b>5. Rack Configuration Planning</b> | 5-1 |
| Using PDUs                            | 5-1 |
| Determining PDU Requirements          | 5-2 |
| Example of PDU Usage Calculation      | 5-4 |

---

|  |     |
|--|-----|
| <b>6. Cabinet and Monitor Requirements</b> | 6-1 |
| Cabinet Requirements                       | 6-1 |
| Monitor Requirements                       | 6-5 |

---

|  |     |
|--|-----|
| <b>Appendix A. System Specifications</b> | A-1 |
| System Specifications                    | A-1 |
| PCIe Adapter Specifications              | A-7 |
| AAP87600 PDU Specifications              | A-8 |

---

|  |      |
|--|------|
| <b>Appendix B. Electrical Circuit and Wiring Information</b> | B-1  |
| Fault Protection Requirements                                | B-1  |
| Grounding Considerations                                     | B-1  |
| Circuit Wiring Diagrams                                      | B-2  |
| Electrical Power Connectors                                  | B-9  |
| PDU Safety Considerations                                    | B-10 |

---

|  |     |
|--|-----|
| <b>Appendix C. Standards Compliance</b>                    | C-1 |
| Electronic Interference, Immunity, Safety, and Noise Level |     |
| Standards Compliance                                       | C-1 |
| Toxic and Hazardous Substances and Elements Disclosure     | C-4 |

---

|              |         |
|--------------|---------|
| <b>Index</b> | Index-1 |
|--------------|---------|

---

## Figures

|             |   |      |
|-------------|---|------|
| Figure 2-1. | System Connected Directly to AC Power                                     | 2-7  |
| Figure 2-2. | PDUs Connected Directly to AC Power                                       | 2-8  |
| Figure 2-3. | Rack-Mountable Systems: A-Side Power Connected Directly to a UPS          | 2-10 |
| Figure 6-1. | Rail Clearance  | 6-4  |
| Figure A-1. | ftServer 27x0, 47x0, 64x0 System: CPU-I/O Enclosures: Front View          | A-2  |
| Figure A-2. | ftServer 27x0, 47x0, 64x0 System: Rear View                               | A-3  |
| Figure A-3. | AAP87600 PDU  | A-9  |
| Figure B-1. | Star Ground Example   | B-2  |
| Figure B-2. | PDU Power Input Labeling  | B-3  |
| Figure B-3. | ftServer Enclosure Power Input Labeling                                   | B-3  |
| Figure B-4. | Single-Phase 120V AC Circuit Connection                                   | B-4  |
| Figure B-5. | Single-Phase 240V AC Circuit Connection                                   | B-5  |
| Figure B-6. | Split-Phase 120/240 Volts AC Circuit Connection                           | B-6  |
| Figure B-7. | Three-Phase 208V AC, Y-, or D-Source Circuit Connection, Phase-to-Phase   | B-7  |
| Figure B-8. | Three-Phase 380V AC, Y-, or D-Source Circuit Connection, Phase-to-Neutral | B-8  |

---

## Tables

|             |   |      |
|-------------|---|------|
| Table 1-1.  | Ethernet PCIe Adapters  | 1-4  |
| Table 1-2.  | ftServer 27x0, 47x0, and 64x0 System Documentation                        | 1-7  |
| Table 1-3.  | Additional System Documentation for Windows-based Systems                 | 1-8  |
| Table 1-4.  | Additional System Documentation for VMware vSphere-based Systems          | 1-9  |
| Table 2-1.  | Worksheet: Determining A-Side Power Requirements                          | 2-3  |
| Table 2-2.  | Worksheet: Determining B-Side Power Requirements                          | 2-3  |
| Table 2-3.  | Worksheet: Determining External Power Requirements                        | 2-4  |
| Table 2-4.  | HVAC Requirements   | 2-4  |
| Table 2-5.  | Worksheet: A-Side External Power Outlet Requirements: PDUs Used           | 2-4  |
| Table 2-6.  | Worksheet: B-Side External Power Outlet Requirements: PDUs Used           | 2-5  |
| Table 2-7.  | Worksheet: A-Side External Power Outlet Requirements: No PDUs             | 2-5  |
| Table 2-8.  | Worksheet: B-Side External Power Outlet Requirements: No PDUs             | 2-5  |
| Table 2-9.  | Power Cords - ftServer Systems and Peripheral Components to AC Power      | 2-11 |
| Table 2-10. | Power Cords Between ftServer Systems or Storage Systems and a UPS         | 2-13 |
| Table 2-11. | Power Cords to Connect PDUs Directly to AC Power Mains                    | 2-13 |
| Table 2-12. | System Power ( <i>Jumper</i> ) Cables to Connect ftServer Systems to PDUs | 2-13 |
| Table 4-1.  | Optical FC Cables   | 4-3  |
| Table 4-2.  | Customer-Supplied Ethernet Cables   | 4-6  |
| Table 5-1.  | Current and Rack-Space Requirements                                       | 5-3  |
| Table 5-2.  | Calculating A-Side PDU and Rack-Space Requirements                        | 5-4  |
| Table 5-3.  | Example: Current and Rack-Space Requirements (208 volts)                  | 5-4  |
| Table 5-4.  | Example: Calculating A-Side PDU and Rack-Space Requirements               | 5-5  |
| Table A-1.  | Cabinet Dimensions  | A-3  |
| Table A-2.  | ftServer 27x0, 47x0, 64x0 System Unit Specifications                      | A-5  |
| Table A-3.  | PCIe Adapter Specifications   | A-8  |
| Table A-4.  | AAP87600 PDU: Specifications  | A-10 |

|            |   |     |
|------------|---|-----|
| Table B-1. | Connectors for AC Power Outlets           | B-9 |
| Table C-1. | Compliance Standards for ftServer Systems | C-2 |



---

# Preface

The *Stratus ftServer 27x0, 47x0, and 64x0 Systems: Site Planning Guide* (R666) documents the site requirements and customer responsibilities related to preparing a site for the installation of ftServer 27x0, 47x0, or 64x0 systems.

This document is intended for those responsible for preparing a site for the installation of an ftServer 27x0, 47x0, or 64x0 system.

## Revision Information

This document is a revision. It adds information about support for Automated Uptime™ Layer for VMware® vSphere™-based ftServer Systems, Release 5.1.0, and VMware ESXi 5.5.

## Notation Conventions

This document uses the notation conventions described in this section.

## Warnings, Cautions, and Notes

Warnings, cautions, and notes provide special information and have the following meanings:



### **WARNING** \_\_\_\_\_

A warning indicates a situation where failure to take or avoid a specified action could cause bodily harm or loss of life.



### **AVERTISSEMENT** \_\_\_\_\_

Un avertissement indique une situation où une omission ou un manque d'action spécifique peut causer une blessure corporelle, voir la mort.



### **CAUTION** \_\_\_\_\_

A caution indicates a situation where failure to take or avoid a specified action could damage a hardware device, program, system, or data.



## MISE EN GARDE

Une mise en garde indique une situation où une omission ou un manque d'action spécifique peut endommager un équipement matériel, un programme, un système ou des données.

## NOTE

A note provides important information about the operation of an ftServer system.

## Typographical Conventions

The following typographical conventions are used in this document:

- The bold font emphasizes words in text or (for Windows-based systems) indicates text that you type, the name of a screen object, or the name of a programming element. For example:

**Before** handling or replacing system components, make sure that you are properly grounded by using a grounded wrist strap.

In the **System Properties** dialog box, click the **Hardware** tab.

Call the **RegisterDeviceNotification** function.

- The italic font introduces new terms and (for Windows-based systems) indicates programming and command-line arguments that the user supplies. For example:

Many hardware components are *customer-replaceable units* (CRUs), which can be replaced on-site by system administrators with minimal training or tools.

**copy** *filename1 filename2*

Pass a pointer for the *NotificationFilter* parameter

- The monospace font indicates sample program code and output, including message text. For example:

```
#include <iostream.h>
The operation completed successfully.
```

The monospace font also represents text that would appear on your display screen when working in a text-based console on a VMware vSphere-based system. The monospace bold font represents text you must type in examples that contain both user input and system output. The monospace italic font represents terms in command lines that are to be replaced by literal values. For example:

To display the state of a CPU enclosure, type a command in the following format:

```
/opt/ft/bin/ftsmaint ls n
```

If you type `/opt/ft/bin/ftsmaint ls 0` at the prompt, the following output appears:

```
H/W Path : 0
Description : Combined CPU/IO
.
.
.
```

- The percent sign (%), dollar sign (\$), and number sign (#) are default prompt signs that have a specific meaning at the command prompt of a VMware vSphere-based system. Although a prompt is sometimes shown at the beginning of a command line as it would appear on the screen, you do not type it.
  - % or \$ indicates you are logged in to a standard user account and are subject to certain access limitations. The prompt displayed on the screen depends on your shell environment, for example, `cs`h (%) or `ba`sh (\$).
  - # indicates you are logged in to the system administrator account and have *superuser* access. Users of this account are referred to as `root`. The # prompt sign used in an example indicates the command can be issued only by `root`.

## Getting Help

If you have a technical question about ftServer system hardware or software, try these online resources first:

- **Online documentation at the StrataDOC Web site.** Stratus provides complimentary access to StrataDOC, an online-documentation service that enables you to view, search, download, and print customer documentation. You can access StrataDOC at the following Web site: <http://stratadoc.stratus.com>

A copy of StrataDOC on supported media for your system is included with this release. To order additional copies of the StrataDOC media or to obtain copies of printed manuals, do one of the following:

- If you are in North America, call the Stratus Customer Assistance Center (CAC) at (800) 221-6588 or (800) 828-8513, 24 hours a day, 7 days a week.
  - If you are located outside North America, contact your nearest Stratus sales office, CAC office, or distributor; for CAC phone numbers outside the U.S., see <http://www.stratus.com/go/support/ftserver/location>.
- **Online support from Stratus Customer Service.** You can find the latest technical information about an ftServer system through online product support at the Customer Support Web site: <http://www.stratus.com/go/support>
  - **Online product support for Microsoft® products.** Your primary source for support is the computer manufacturer who provided your software, or an authorized Microsoft Support Provider. You can also find the latest technical information about Microsoft Windows® and other Microsoft products through online product support at the [Microsoft Help and Support Web site: http://support.microsoft.com/](http://support.microsoft.com/)
  - **Online product support for VMware vSphere products.** You can find the latest technical information about VMware vSphere through online product support at the VMware Support Web site: <http://www.vmware.com/support/>

If you are unable to resolve your questions with the help available at these online sites, and the ftServer system is covered by a service agreement, please contact the Stratus Customer Assistance Center (CAC) or your authorized Stratus service representative. For information about how to contact the CAC, see the following Web site: <http://www.stratus.com/go/support/ftserver/location>

## Commenting on the Documentation

To provide corrections and suggestions on the documentation, send your comments in one of the following ways:

- By clicking the **site feedback** link at the bottom of a Help topic. Information to identify the topic is supplied in the StrataDOC Web Site Feedback form.
- By email to [Comments@stratus.com](mailto:Comments@stratus.com). If it is possible, please include specific information about the documentation on which you are commenting:
  - For a printed document or a document in PDF format, include the title and part number from the Notice page and the page numbers.
  - For online documentation, include the Help subject and topic title.

This information will assist Stratus Information Development in making any needed changes to the ftServer system documentation. Your assistance is most appreciated.

## Regulatory Notice

All regulatory notices are provided in the site planning guide for your system.



---

# Chapter 1

## Site Planning for ftServer 27x0, 47x0, and 64x0 Systems

For an overview of required information and tasks you need to perform to prepare a site for ftServer 27x0, 47x0, and 64x0 systems, see:

- [“Site Planning Overview” on page 1-1](#)
- [“Site Planning Checklist” on page 1-3](#)
- [“System Documentation” on page 1-7](#)
- [“Safety Notices” on page 1-10](#)

### Site Planning Overview

Site planning for fault-tolerant systems includes:

- [Purchasing an appropriate cabinet and monitor](#)

If you do not purchase a monitor from Stratus, provide a monitor that meets the system’s requirements.

#### NOTE \_\_\_\_\_

A monitor, keyboard, and mouse are required to install Automated Uptime Layer.

If you do not purchase a cabinet from Stratus, provide a cabinet that meets the system’s requirements.

- [Electrical power planning](#)

Provide electrical power sources that meet the requirements of the system and optional components, optionally including the purchase of a qualified [uninterruptible power supply \(UPS\)](#).

- **Space planning**

Provide adequate space for the system or cabinet and for a desk or table to accommodate components outside a cabinet. Also provide enough space for servicing the systems and components.

Provide an environment that meets the system's requirements for ambient temperature and air quality.

- **Communications line planning**

Provide sufficient network and analog telephone lines and plan the location of the system and external components to accommodate the lengths of the connecting cables.

- **Rack space planning**

Ensure that the power distribution units (PDUs) supply sufficient power to the components you have purchased and that you have sufficient space available in an appropriate cabinet.

Use the “[Site Planning Checklist](#)” on page 1-3 to track your site preparation progress.

For information about obtaining documents related to your ftServer system, see “[System Documentation](#)” on page 1-7.

During the site planning and preparation processes, work closely with your facilities group or contractor to determine space, power, and environmental requirements. Enlist their help to provide a suitable location with sufficient alternating current (AC) power, heating, ventilation and air conditioning (HVAC) capabilities, and network and telephone connections.

If your system is covered by a service agreement and you need help with site planning, contact the Stratus Customer Assistance Center (CAC) or your authorized Stratus service representative. If you have a contract with the CAC or your authorized Stratus service representative to install the system, contact them after you have prepared the installation site and moved the system to the site. For more information about the CAC, see [Getting Help](#) in the Preface or the <http://www.stratus.com/go/support> Web site.

See [Appendix A](#) for the specifications of the base ftServer systems and of PDUs. See the *Stratus ftServer Systems: Peripherals Site Planning Guide* (R582) for specifications of other components.



## The Stratus ActiveService Network

The Stratus ActiveService Network (ASN) is a network that allows your ftServer system to automatically report problems to the Stratus Customer Assistance Center (CAC) or your authorized Stratus service representative, and that can allow the CAC or your authorized Stratus service representative to remotely diagnose, troubleshoot, and resolve problems online.

To enable connectivity to the ASN, you connect a pair of partnered Ethernet ports, one from each CPU-I/O enclosure in your system, to a network that has Internet access. For additional protection, if you connect the Ethernet port of the VTM in each enclosure to a network with Internet access, the VTMs can communicate with the ASN even when the host operating system is not running or is unresponsive.

If Internet access is not available, or if you wish to have a backup method of connecting to the ASN, you can also install the optional ASN modem in your system, which allows either the host operating system or a VTM to communicate with the ASN through a telephone dialup connection.

## Site Planning Checklist

Referring to the information in this document, answer the following questions:

### Planning for ASN Connectivity

- Will your system connect to the ASN? If so, will it connect over an ASN modem or the Internet?
- If your system will use the Internet to connect to the ASN, do you have an Internet connection available?
- If your system will use an ASN modem, do you have an external analog telephone line available for the ASN modem?

### NOTE

A dedicated phone line provides the most reliable service. ASN calls routed through a PBX may be slow due to load on the PBX, or may not complete successfully due to disconnections. If you must use a PBX, do not route the telephone extension through a switchboard; instead, provide a direct-dial analog number.

- Do you have an additional telephone connection and telephone near the operator's station for voice communications when calling for support?

### Planning for Network Connectivity

- ❑ All ftServer 27x0, 47x0, and 64x0 systems contain four embedded 1-gigabit Ethernet (GbE) ports that operate at 10 or 100 Megabits-per-second (Mbps) or at 1 gigabit-per-second (Gbps). In addition, four embedded 10-GbE ports are standard on ftServer 64x0 systems and optional on ftServer 47x0 systems. Also, you can add optional Ethernet PCI adapters to provide additional Ethernet bandwidth.

Will your system additionally include any of the following PCI adapters? If so, in [Table 1-1](#), indicate the total number of ports, and plan network connections for all Ethernet ports you will use.

**Table 1-1. Ethernet PCIe Adapters**

| Adapter  | Total Number of Ports |
|--|-----------------------|
| Embedded Dual-Port 1GbE Base-T Ethernet PCI-Express Adapters (2)             | 4                     |
| Embedded Dual-Port 10-Gigabit Ethernet PCI-Express Adapters (2) <sup>†</sup> |                       |
| U105 Dual-Port 10/100/1000 Base-T Ethernet PCI-Express Adapter               |                       |
| U584 Dual-Port Fiber 10-Gigabit Ethernet PCI-Express Adapter                 |                       |

<sup>†</sup> Standard on ftServer 64x0 systems; provided on ftServer 47x0 systems if you purchase the optional PCI riser assembly; not available on ftServer 27x0 systems. See [“Category-6/Category-6A Cables” on page 4-7](#) for additional site-planning requirements for embedded 10-GbE ports.

### Planning for External Storage Options

- ❑ Will your system connect to external Fibre Channel storage enclosures? If so, the system requires a pair of Fibre Channel HBAs, which are provided when you order the storage enclosure. If you order the enclosure at the same time you order the system, the required Fibre Channel HBAs are installed at the factory. See the *Stratus ftServer Systems: Peripherals Site Planning Guide* (R582) for descriptions of the storage enclosures provided by Stratus and the names of the PCI adapters required for supported storage enclosures.

## NOTES \_\_\_\_\_

1. ftServer systems support first-generation ftScalable™ Storage systems, ftScalable Storage G2 systems, and EMC® CLARiiON® or Symmetrix® storage systems.
  2. If you plan to connect an EMC storage system to a VMware vSphere-based ftServer system, ensure that you receive approval for your configuration by submitting a request through EMC's RPQ process to guarantee EMC support.
- Will your system connect to external Fibre Channel storage enclosures in a storage area network (SAN) configuration? If so, do you have a minimum of two switches that can accommodate the cables from the pair of Fibre Channel HBAs in each ftServer system?

## NOTE \_\_\_\_\_

Stratus has successfully tested the Brocade® 200E and 5100 Fibre Channel switches, as well as the QLogic® SANbox® 5800V switch. Other model switches may also be compatible as long as they can be configured in the same manner as the Brocade 200E or 5100 switch, or the QLogic 5800V switch.

- Will your system have an iSCSI connection to ftScalable Storage G2 systems or EMC CLARiiON storage systems? If so, ensure that you supply two Ethernet switches that can accommodate the cables from the network adapters in each ftServer system.
- Set up your system to communicate with a UPS.

**Planning for Optional Components**

- Will you supply your own monitor, or will Stratus supply the monitor, keyboard, and mouse? Is the monitor rack-mountable, or do you need to provide a table or desk?
- Will you connect a SAS tape drive (customer-supplied) to your system?

## NOTE \_\_\_\_\_

VMware vSphere-based systems do not support tape drives.

### Planning AC Power

- Will you provide power to both sides of the system through a pair of PDUs?
- Will you protect the system power with a UPS?
- What optional components will you use?
- What are the AC power requirements of your system, including all optional components?
- What are the lengths and types of the power cords that are provided for the PDUs or system, and optional components?
- What type of AC receptacles do you need to provide?
- Is the AC power service wired properly?

### Planning Space for Your System

- Will your system and its external components fit where you plan to place them?
- What is the height of the cabinet you will use, and what is the total height of the systems and components that will be installed in the cabinet? Will the items fit into the cabinet? What components will be located outside the cabinet?
- What are the lengths and types of the interface and communications cables that will connect to your system?
- Have you created a sketch of how you plan to arrange the system at the installation site? Consider the available cable lengths, the placement of external devices, and the location of network and voice communication connections.

On the sketch, show the following:

- Location of the system and its external components
- Power cords, and telephone and interface cables
- Locations of AC power receptacles, phone jacks, Ethernet jacks, switches, and hubs

#### NOTE \_\_\_\_\_

Make sure that all cords and cables are long enough to reach between their respective components and connectors. Route all cables out of the way of foot traffic.

## Working with Other Groups

- ❑ Have you provided your facilities group and contractors with the sketch of how you plan to arrange the system and copies of the following?
  - [“AC Power and HVAC Service Requirements” on page 2-2](#)
  - [“Redundant Power Sources” on page 2-1](#)
  - Tables [2-1](#), [2-2](#), and [2-3](#), worksheets for determining AC power requirements
  - Tables [2-5](#) and [2-6](#) (if you are using PDUs) or Tables [2-7](#) and [2-8](#) (if you are not using PDUs), worksheets for determining the number of external power outlets required
  - [Appendix B, “Electrical Circuit and Wiring Information”](#)
  - Any notes you have about site planning
  
- ❑ Have you reviewed and discussed the requirements with the facilities personnel and contractors to ensure that all site modifications are understood and implemented?

If you have any questions about the number and types of components, contact your Stratus account representative or distributor.

## System Documentation

[Table 1-2](#) lists the hardware documents for ftServer 27x0, 47x0, and 64x0 systems, and the tasks described in each document. Also see [Table 1-3](#) for Windows-based systems or [Table 1-4](#) for VMware vSphere-based systems.

**Table 1-2. ftServer 27x0, 47x0, and 64x0 System Documentation**

| Document  | Task  |
|---|---|
| <i>Stratus ActiveService Network Configuration Guide (R072)</i>   | Configure your system for support by the ASN  |
| <i>Stratus ftServer Systems: PCI Adapter Guide (R461)</i>         | Install, configure, replace, or troubleshoot PCI adapters   |
| <i>Stratus ftServer Systems: Technical Reference Guide (R550)</i> | <p>Consult technical reference information for ftServer systems</p> <p>View or change BIOS settings in the system BIOS setup utility</p> <p>Use the Unified Extensible Firmware Interface (UEFI) to configure the BMC and configure user accounts</p> |

**Table 1-2. ftServer 27x0, 47x0, and 64x0 System Documentation (Continued)**

| Document   | Task  |
|--|---|
| <i>Stratus ftServer Systems: Peripherals Site Planning Guide (R582)</i>                      | Find information about optional equipment that you have ordered with your system that is needed to complete site preparation            |
| <i>Stratus ftServer Virtual Technician Module User's Guide (R642)</i>                        | Use the VTM console to remotely control, monitor, and troubleshoot your system  |
| <i>Read Me First: Unpacking ftServer 27x0, 47x0, and 64x0 Systems (R663)</i>                 | Inspect and unpack ftServer system hardware that you install in your cabinet  |
| <i>Stratus ftServer 27x0, 47x0, and 64x0 Systems: Operation and Maintenance Guide (R667)</i> | Start up, shut down, and operate your system<br><br>Troubleshoot system hardware<br><br>Remove and replace CRUs, including PCI adapters |
| <i>Stratus ftServer 27x0, 47x0, and 64x0 Systems: Installation Guide (R668)</i>              | Install your system, including mounting the system in a cabinet   |
| <i>ftScalable Storage: Getting Started Guide (R601)</i>                                      | Install and initially configure a first-generation ftScalable Storage system  |
| <i>ftScalable Storage G2: Getting Started Guide (R651)</i>                                   | Install and initially configure an ftScalable Storage G2 system   |

Table 1-3 lists additional documentation for Windows-based systems.

**Table 1-3. Additional System Documentation for Windows-based Systems**

| Document  | Task   |
|---|--|
| <i>Release Notes: Stratus Automated Uptime Layer for Windows-based ftServer Systems (R004W)</i> | Learn the contents of the latest Automated Uptime Layer release<br><br>Learn the latest information about the product<br><br>Learn about significant known problems and how to work around or avoid the problems |

**Table 1-3. Additional System Documentation for Windows-based Systems** (Continued)

| Document   | Task   |
|--|--|
| <i>Stratus Automated Uptime Layer for Windows-based ftServer Systems: Installation and Configuration</i> (R002W) | <p>Respond to Mini-Setup questions</p> <p>Install or reinstall Automated Uptime Layer and Windows Server software</p> <p>Install the operating system on your new system</p> <p>Upgrade software and BIOS and BMC firmware</p> <p>Configure Automated Uptime Layer</p> <p>Set up your system to communicate with a UPS</p> <p>Configure VTMs</p> |
| <i>Stratus ftServer System Administrator's Guide for the Windows Operating System</i> (R014W)                    | <p>Use tools that are provided by the operating system software, Automated Uptime Layer, and other vendors to manage and troubleshoot the system</p> <p>Manage data-storage devices</p>  |

[Table 1-4](#) lists additional documentation for VMware vSphere-based systems.

**Table 1-4. Additional System Documentation for VMware vSphere-based Systems**

| Document  | Task  |
|---|---|
| <i>Release Notes: Stratus Automated Uptime Layer for VMware vSphere-based ftServer Systems</i> (R001E)                  | <p>Learn the contents of the latest Automated Uptime Layer release</p> <p>Learn the latest information about the product</p> <p>Learn about significant known problems and how to work around or avoid the problems</p> |
| <i>Stratus Automated Uptime Layer for VMware vSphere-based ftServer Systems: Installation and Configuration</i> (R004E) | <p>Install, update, and configure VMware ESXi, Automated Uptime Layer, and BIOS and BMC firmware</p> <p>Configure VTMs</p> <p>Set up your system to communicate with a UPS</p>  |

**Table 1-4. Additional System Documentation for VMware vSphere-based Systems (Continued)**

| Document  | Task  |
|---|---|
| <i>Stratus ftServer System Administrator's Guide for VMware vSphere (R002E)</i> | Use tools that are provided by VMware vSphere, Automated Uptime Layer, and other vendors to manage and troubleshoot the system<br><br>Manage data storage devices |
| VMware vSphere Storage <sup>†</sup>   | Learn how to set up and manage a system using VMware vSphere with Fibre Channel storage area networks (SANs) or iSCSI storage systems                             |

† Available from VMware at <http://www.vmware.com/support/pubs/>.

## Safety Notices

 **WARNING** \_\_\_\_\_  
**Risk of explosion if battery is replaced by an incorrect type. Dispose of used batteries according to the instructions provided with the battery.**

 **WARNING** \_\_\_\_\_  
**The system uses two power cords to provide redundant sources of power. To fully remove power from a system, disconnect both power cords. To reduce the risk that electrical shock could injure a person or damage the system, exercise caution when working in the unit even when only one power cord is connected.**

 **WARNING** \_\_\_\_\_  
**To prevent a cabinet from tipping over and injuring a person or damaging the system, start installing systems from the bottom of the cabinet upward.**

 **WARNING** \_\_\_\_\_  
**If you replace the modem cable supplied by Stratus, use a cable with a gauge of at least 26 AWG to prevent fire.**



**WARNING** \_\_\_\_\_

To avoid fire, electric shock, and equipment breakdown, prevent water or foreign objects from getting into the equipment. Do not let water or foreign objects, such as pins or paper clips, enter the equipment.

**WARNING** \_\_\_\_\_

To prevent fire or current leakage, do not plug the power cord into a nonconforming outlet. Use a power outlet with appropriate voltage and power type, as specified in this guide.

**WARNING** \_\_\_\_\_

Do not install the equipment where you may need an extension cord. Use of an extension cord that does not meet the power specifications introduces a risk of overheating that could lead to a fire.

**WARNING** \_\_\_\_\_

Disconnect the power cords from the server or power source before you install or relocate the equipment. All voltage is removed only when the power cords are disconnected.

**WARNING** \_\_\_\_\_

Do not install or store the equipment in an unsuitable place. Install or store the equipment in a place that meets the requirements specified in this guide. Avoid the following conditions to avoid the risk of fire:

- Dust
- High humidity, such as a place near a boiler
- Direct sunlight
- Instability, such as places not stabilized against earthquakes



**WARNING** \_\_\_\_\_

**Do not use or store this product in a corrosive environment.**

**Avoid using or storing this product in an environment which may contain corrosive gases. Such gases include, but are not limited to, sulfur dioxide, hydrogen sulfide, nitrogen dioxide, chlorine, ammonia or ozone.**

**Avoid installing this product in a dusty environment or one that may contain corrosive materials such as sodium chloride or sulfur.**

**Avoid installing this product in an environment which may contain excessive metal flakes or conductive particles in the air.**

**Such environments may cause corrosion or short circuits within this product, resulting in not only damage to this product, but also fire.**

**If there are any concerns regarding the environment at the planned site of installation or storage, please contact your CAC or your authorized Stratus service representative.**



**WARNING** \_\_\_\_\_

**When installing a system or CRU, always connect the power cord first, before adding communications cables. The power cord contains the protective earth connection; it should be connected first and disconnected last, to maintain a grounded chassis.**

**Before attempting to remove a CRU from the system chassis, make sure to power off the CRU, disconnect communications cables, and then disconnect the power cord.**

**Never connect a power cord to a CRU when it is not located within the system chassis.**

**WARNING** \_\_\_\_\_

Do not disassemble, repair, or alter the server, except as described in the *Stratus ftServer 27x0, 47x0, and 64x0 Systems: Operation and Maintenance Guide* (R667). There is a risk of an electric shock or fire as well as equipment malfunction if you do not observe the instructions in the *Stratus ftServer 27x0, 47x0, and 64x0 Systems: Operation and Maintenance Guide* (R667).

**WARNING** \_\_\_\_\_

Do not place any object on top of the server. The object may fall off and cause injuries, damage to hardware, or a fire.

**WARNING** \_\_\_\_\_

Do not leave the DVD tray ejected. Dust may enter the equipment and cause it to malfunction. The ejected tray may also become a cause of injuries.

## Consignes de sécurité

**AVERTISSEMENT** \_\_\_\_\_

Risque d'explosion si la batterie est remplacée par une autre de type incorrect. Jeter les batteries usagées conformément aux instructions fournies avec la batterie.

**AVERTISSEMENT** \_\_\_\_\_

Le système utilise deux cordons d'alimentation pour fournir des sources d'alimentation redondantes. Pour mettre un système entièrement hors tension, débrancher les deux cordons d'alimentation. Pour réduire le risque qu'un choc électrique puisse blesser une personne ou endommager le système, utiliser l'unité avec prudence même lorsqu'un seul cordon d'alimentation est branché.



**AVERTISSEMENT** \_\_\_\_\_

Pour éviter qu'une armoire ne bascule et blesse une personne ou endommage le système, commencer par installer les systèmes de bas en haut de l'armoire.



**AVERTISSEMENT** \_\_\_\_\_

En cas de remplacement du câble de modem fourni par Stratus, utiliser un câble homologué UL dont le calibre est d'au moins 26 AWG afin de prévenir les incendies.



**AVERTISSEMENT** \_\_\_\_\_

Pour éviter tout risque d'incendie, de choc électrique et de panne de matériel, empêcher l'eau ou les objets étrangers d'entrer dans l'équipement. Ne pas laisser d'eau ou d'objets étrangers, tels que des agrafes ou des trombones, entrer dans l'équipement.



**AVERTISSEMENT** \_\_\_\_\_

Pour éviter tout risque d'incendie ou de fuite de courant, ne pas brancher le cordon d'alimentation dans une prise non conforme. Utiliser une prise de courant avec une tension et un type d'alimentation appropriés, tel qu'indiqué dans ce guide.



**AVERTISSEMENT** \_\_\_\_\_

Ne pas installer l'équipement dans un lieu où une rallonge pourrait être nécessaire. L'utilisation d'une rallonge ne respectant pas les spécifications électriques présente un risque de surchauffe pouvant provoquer un incendie.



**AVERTISSEMENT** \_\_\_\_\_

Débrancher les cordons d'alimentation du serveur ou de la source d'alimentation avant d'installer ou de déplacer l'équipement. Toute la tension n'est coupée que lorsque les cordons d'alimentation sont débranchés.



## **AVERTISSEMENT** \_\_\_\_\_

**Ne pas installer ou entreposer l'équipement dans un lieu inadapté. Installer ou entreposer l'équipement dans un lieu qui satisfait aux exigences spécifiées dans ce guide. Éviter les situations suivantes pour empêcher le risque d'incendie:**

- **Poussière**
- **Forte humidité, comme à proximité d'une chaudière**
- **Exposition directe au soleil**
- **Instabilité, comme des endroits non stabilisés contre les tremblements de terre**



## **AVERTISSEMENT** \_\_\_\_\_

**Ne pas utiliser ou entreposer ce produit dans un environnement corrosif.**

**Éviter d'utiliser ou d'entreposer ce produit dans un environnement qui pourrait contenir des gaz corrosifs. Ces gaz incluent, mais sans s'y limiter, du dioxyde de soufre, du sulfure d'hydrogène, du dioxyde d'azote, du chlore, de l'ammoniac ou de l'ozone.**

**Éviter d'installer ce produit dans un environnement poussiéreux ou qui pourrait contenir des matériaux corrosifs, tels que du chlorure de sodium ou du soufre.**

**Éviter d'installer ce produit dans un environnement qui pourrait contenir des éclats de métal excessifs ou des particules conductrices dans l'air.**

**Ces environnements peuvent causer une corrosion ou des courts-circuits dans ce produit, ce qui endommage non seulement le produit, mais peut aussi provoquer un incendie.**

**Pour toute question concernant l'environnement sur le site planifié de l'installation ou de l'entreposage, veuillez communiquer avec votre centre d'assistance à la clientèle (CAC).**



#### AVERTISSEMENT \_\_\_\_\_

Lors de l'installation d'un système ou d'une unité remplaçable par le client (CRU), commencez toujours par brancher le cordon d'alimentation, avant d'ajouter les câbles de communications. Le cordon d'alimentation est équipé d'une connexion de terre de protection; il doit être branché en premier et débranché en dernier afin de conserver un châssis relié à la terre.

Avant d'essayer d'enlever une CRU du châssis du système, veillez à bien mettre la CRU hors tension, à débrancher les câbles de communications, puis à débrancher le cordon d'alimentation.

Ne jamais brancher un cordon d'alimentation à une CRU lorsqu'elle n'est pas à l'intérieur du châssis du système.



#### AVERTISSEMENT \_\_\_\_\_

Ne pas démonter, réparer ou modifier le serveur, sauf conformément à ce qui est décrit dans le *Stratus ftServer 27x0, 47x0, and 64x0 Systems: Operation and Maintenance Guide* (R667). Il existe un risque de choc électrique ou d'incendie, ainsi que de défaillance de l'équipement, si vous ne respectez pas les instructions décrites dans le *Stratus ftServer 27x0, 47x0, and 64x0 Systems: Operation and Maintenance Guide* (R667).



#### AVERTISSEMENT \_\_\_\_\_

Ne placer aucun objet au-dessus du serveur. L'objet pourrait tomber et causer des blessures, endommager le matériel ou provoquer un incendie.



#### AVERTISSEMENT \_\_\_\_\_

Ne pas laisser le plateau du DVD ouvert. De la poussière pourrait entrer dans l'équipement et causer une défaillance. Le plateau d'éjection pourrait également causer des blessures en position ouverte.

## Safety Notices (Traditional Chinese)

### 安全注意事項



#### WARNING

若錯誤更換電池類型，將產生爆炸風險。請按電池包裝說明，妥善丟棄已耗廢電池。



#### WARNING

系統採用兩條電源線，以提供冗餘電源。欲徹底清除系統電源，先拔下兩條電源線。為降低觸電所導致的人體傷害或系統損害，請小心操作機體，即使系統僅插入一條電源線。



#### WARNING

欲預防儲櫃翻倒，進而導致人體傷害或系統損害，請從儲櫃下方開始往上安裝系統。



#### WARNING

若您更換由Stratus供應的數據機纜線，請使用至少有26 AWG壓力的纜線，避免發生火災。



#### WARNING

避免火災、觸電、設備故障、液體或其他異物進入設備。不得讓液體或類似圖釘或迴紋針等異物進入設備。



**WARNING** \_\_\_\_\_

為避免火災或漏電，不得將電源線插入規格不符的的插座中。請使用本指南指定之電壓及電源類別的的插座。



**WARNING** \_\_\_\_\_

不得使用延長線安裝設備。使用與指定電源規格不符的延長線會產生設備過熱風險，進而可能導致火災。



**WARNING** \_\_\_\_\_

安裝或移動設備前，請從伺服器或電源拔下電源插頭。

只有在拔下電源線後，設備的所有電壓才會消除。



**WARNING** \_\_\_\_\_

不得在不適合場所安裝或存放設備。請按本指南指定且符合規格要求的場所安裝或存放設備。避免下列可能產生火災風險的地方：

- 灰塵較多

- 熱水器旁濕氣較重的地方

- 陽光直照的地方

- 不穩位置，例如易受地震影響的地方



 **WARNING**

不得在腐蝕性環境中使用或存放產品。避免在含腐蝕性氣體的環境使用或存放本產品，其中包括但不限於：二氧化硫、氫化硫、氮、氫、氯或臭氧。

不得將本產品安裝在灰塵較多或含類似氯化鈉或硫磺等腐蝕性物質的地方。

不得將本產品安裝在空氣中含過量金屬碎片或傳導粒子的地方。

上述環境可能導致本產品腐蝕或短路，因而損壞產品，甚至引起火災。若對產品安裝或存放的場地環境規劃有任何疑問，請與CAC或授權Stratus服務代表聯絡。

 **WARNING**

不得在伺服器已連接電源的狀態下連接界面電纜。安裝或移除任何內建裝置，或從伺服器拔下或連接任何界面電纜前，確認已關閉伺服器的電源，並從伺服器或電插座拔下電纜線。即使伺服器電源已切斷，在仍連接電源的狀態下，碰觸內建裝置、電纜或連接器也可能產生觸電、或因短路而引起火災。

 **WARNING**

除 *Stratus ftServer 27x0、47x0和 64x0系統：操作和維修指南 (R667)* 之說明外，不得以任何方式拆卸、修理或改裝伺服器。若未遵循 *Stratus ftServer 27x0、47x0和 64x0系統：操作和維修指南 (R667)* 的說明指示，將可能產生觸電、火災以及設備故障的風險。



**WARNING** \_\_\_\_\_

不得在伺服器上放置任何物件。物件可能會掉落而導致人體傷害、硬體損壞或火災。



**WARNING** \_\_\_\_\_

DVD光碟機不得靜置於彈出位置。灰塵進入設備將導致功能異常。彈出的光盤也可能是導致設備損壞的來源。

---

## Chapter 2

# Electrical Power Planning

For information about planning appropriate AC electrical power for your system and its peripheral components, see:

- [“Redundant Power Sources” on page 2-1](#)
- [“AC Power and HVAC Service Requirements” on page 2-2](#)
- [“Selecting a UPS Unit for ftServer Systems” on page 2-9](#)
- [“Power Cord Summary” on page 2-11](#)
- [“Grounding Requirements” on page 2-14](#)

### Related Topic

- [Chapter 5, “Rack Configuration Planning”](#)

## Redundant Power Sources

ftServer systems require at least two separate and independent AC power sources—an *A-side* power source and a *B-side* power source—that provide power to the system’s power receptacles, labeled A and B, respectively. Either source must be capable of continuing to provide power if power to the other source is lost.

The A-side power source provides power to one side of each system and storage enclosure, as well as to components that do not require two sources of power, such as tape-drive enclosures and a monitor. If you use an uninterruptible power supply (UPS), the UPS is, in these standard, documented, configurations, the A-side power source.

The B-side power source provides power to the other side of each system and storage enclosure.

The wattage required from the A-side power source will always be equal to or greater than the wattage required from the B-side power source.

## AC Power and HVAC Service Requirements

From the *Stratus ftServer Systems: Peripherals Site Planning Guide* (R582), obtain the nominal input line voltage (volts AC) and frequency (Hz) required for optional, AC-powered components. In general, provide 100–127 VAC or 200–240 VAC at 50 or 60 Hz for optional components. PDUs require 200–240 VAC at 50 or 60 Hz. Operating the system at the higher end of the voltage range, when possible, results in higher power system efficiency and consequently less generated heat and lower utility costs.

For detailed information about the plug types and lengths of the power cords provided with the system, see [“Power Cord Summary” on page 2-11](#).

The power service must be properly wired and grounded according to local standards and regulations. See [Appendix B](#) for more information.

### NOTE

A branch circuit breaker with ground fault protection must allow a minimum of 3.5 milliamperes (mA) leakage current for each power cord.

Use the following worksheets to determine AC power requirements for the site.

- In [Table 2-1](#), determine the power requirements at the A-side power source.
- In [Table 2-2](#), determine the power requirements at the B-side power source.
- In [Table 2-3](#), determine the power requirements for components outside of the cabinet. These components can share a power source with the A-side or B-side components.
- In [Table 2-4](#), determine the related HVAC requirements.

### To determine AC power requirements

Provide information in [Tables 2-1](#), [2-2](#), and [2-3](#) as follows:

1. In the Quantity column, write the number of each type of component.
2. Multiply the entry in the Quantity column by the number in the Watts column, and enter the result in the Watts Subtotal column.
3. Add the values in the Watts Subtotal column, and enter the sum on the bottom line. This value indicates the maximum power requirement for each power source.

**Table 2-1. Worksheet: Determining A-Side Power Requirements**

| System Component                       | Quantity | Watts | Watts Subtotal |
|--|----------|-------|----------------|
| ftServer systems                       |          | x 700 |                |
| Monitor unit <sup>†</sup>              |          | x     |                |
| Storage enclosure <sup>‡</sup>         |          | x     |                |
| Fibre Channel switch <sup>‡</sup>      |          | x     |                |
| User-supplied components               |          |       |                |
| <b>TOTAL A-SIDE POWER REQUIREMENTS</b> |          |       |                |

<sup>†</sup> See the *Stratus ftServer Systems: Peripherals Site Planning Guide* (R582) for the wattage of optional components you purchase from Stratus.

<sup>‡</sup> If you are using Fibre Channel switches to connect the systems to storage enclosures, include on this line the power requirements for a Fibre Channel switch. Two switches are required for fault-tolerant operation. Connect one switch to A-side power and the other switch to B-side power.

**Table 2-2. Worksheet: Determining B-Side Power Requirements**

| System Component                       | Quantity | Watts | Watts Subtotal |
|--|----------|-------|----------------|
| ftServer systems                       |          | x 700 |                |
| Storage enclosure <sup>†</sup>         |          | x     |                |
| Fibre Channel switch <sup>‡</sup>      |          | x     |                |
| User-supplied components               |          |       |                |
| <b>TOTAL B-SIDE POWER REQUIREMENTS</b> |          |       |                |

<sup>†</sup> See the *Stratus ftServer Systems: Peripherals Site Planning Guide* (R582) for the wattage of optional components you purchase from Stratus.

<sup>‡</sup> If you are using Fibre Channel switches to connect the systems to storage enclosures, include on this line the power requirements for a Fibre Channel switch. Two switches are required for fault-tolerant operation. Connect one switch to A-side power and the other switch to B-side power.

**Table 2-3. Worksheet: Determining External Power Requirements**

| System Component                         | Watts |
|--|-------|
| Other peripheral components              |       |
| <b>TOTAL EXTERNAL POWER REQUIREMENTS</b> |       |

**To determine HVAC requirements**

1. Add together the values from the Total row of Tables 2-1, 2-2, and 2-3, and enter the value in the Total Watts column of Table 2-4.
2. Multiply the value in the Total Watts column by 3.41, and enter the number of BTUs in the BTUs/hr. Subtotal column.

**Table 2-4. HVAC Requirements**

| Total Watts<br>(From Tables 2-1, 2-2, and 2-3) | Convert to BTUs | BTUs/hr. Subtotal |
|--|-----------------|-------------------|
|  | x 3.41 =        |                   |

**AC Power Outlet Requirements**

If you **do** use a pair of PDUs in the cabinet, use Tables 2-5 and 2-6 to determine the total number of power outlets required **outside the cabinet**.

1. In the Quantity column, write the number of each type of component.
2. Multiply the value in the Quantity column by the value in the Outlets column, and enter the total in the Subtotal column.
3. Add the values in the Subtotal column and enter the sum next to TOTAL NUMBER OF A-SIDE POWER OUTLETS and TOTAL NUMBER OF B-SIDE POWER OUTLETS.

**Table 2-5. Worksheet: A-Side External Power Outlet Requirements: PDUs Used**

| Component                                   | Quantity |   | Outlets | Subtotal |
|---|----------|---|---------|----------|
| PDUs  |          | x | 1       |          |
| Other external components                   |          |   |         |          |
| <b>TOTAL NUMBER OF A-SIDE POWER OUTLETS</b> |          |   |         |          |

**Table 2-6. Worksheet: B-Side External Power Outlet Requirements: PDUs Used**

| Component                                   | Quantity |   | Outlets | Subtotal |
|---|----------|---|---------|----------|
| PDUs  |          | x | 1       |          |
| Other external components                   |          |   |         |          |
| <b>TOTAL NUMBER OF B-SIDE POWER OUTLETS</b> |          |   |         |          |

If you do **not** use PDUs in the cabinet, use Tables 2-7 and 2-8 to determine the number of AC power outlets required **outside the cabinet**.

1. In the Quantity column, write the number of each type of component.
2. Multiply the value in the Quantity column by the value in the Outlets column, and enter the total in the Subtotal column.
3. Add the values in the Subtotal column and enter the sum next to TOTAL NUMBER OF A-SIDE POWER OUTLETS and TOTAL NUMBER OF B-SIDE POWER OUTLETS.

**Table 2-7. Worksheet: A-Side External Power Outlet Requirements: No PDUs**

| Component                                   | Quantity |   | Outlets | Subtotal |
|---|----------|---|---------|----------|
| ftServer systems                            |          | x | 1       |          |
| Storage enclosures                          |          | x | 1       |          |
| LCD monitor units or external monitors      |          | x | 1       |          |
| Tape-drive enclosure                        |          | x | 1       |          |
| Other peripheral components                 |          |   |         |          |
| <b>TOTAL NUMBER OF A-SIDE POWER OUTLETS</b> |          |   |         |          |

**Table 2-8. Worksheet: B-Side External Power Outlet Requirements: No PDUs**

| Component                                   | Quantity |   | Outlets | Subtotal |
|---|----------|---|---------|----------|
| ftServer systems                            |          | x | 1       |          |
| Storage enclosures                          |          | x | 1       |          |
| Other peripheral components                 |          |   |         |          |
| <b>TOTAL NUMBER OF B-SIDE POWER OUTLETS</b> |          |   |         |          |

## Connecting a System Directly to Separate AC Sources

If you do not connect your ftServer system or PDUs to a UPS, provide two AC power sources that are as electrically independent of each other as the installation site allows.

At a minimum, the two power sources must be powered by separate circuit breakers (maximum of 20A) to AC power and, if possible, be independent of each other beyond that level. The more electrical separation between the two power sources, the less likely they will both fail at the same time. Due to redundancy in ftServer systems, power to either side of the system keeps the system in operation, although the system is no longer fault-tolerant.

[Figure 2-1](#) shows how to connect rack-mounted ftServer 27x0, 47x0, and 64x0 systems directly to two separate AC power sources. [Figure 2-2](#) shows how to connect PDUs directly to two separate power sources.

### NOTE

Do not connect PDUs or peripheral components to a Stratus-qualified UPS, which is sized only for the ftServer system. For more information, see [“Selecting a UPS Unit for ftServer Systems”](#) on page 2-9.



Figure 2-1. System Connected Directly to AC Power

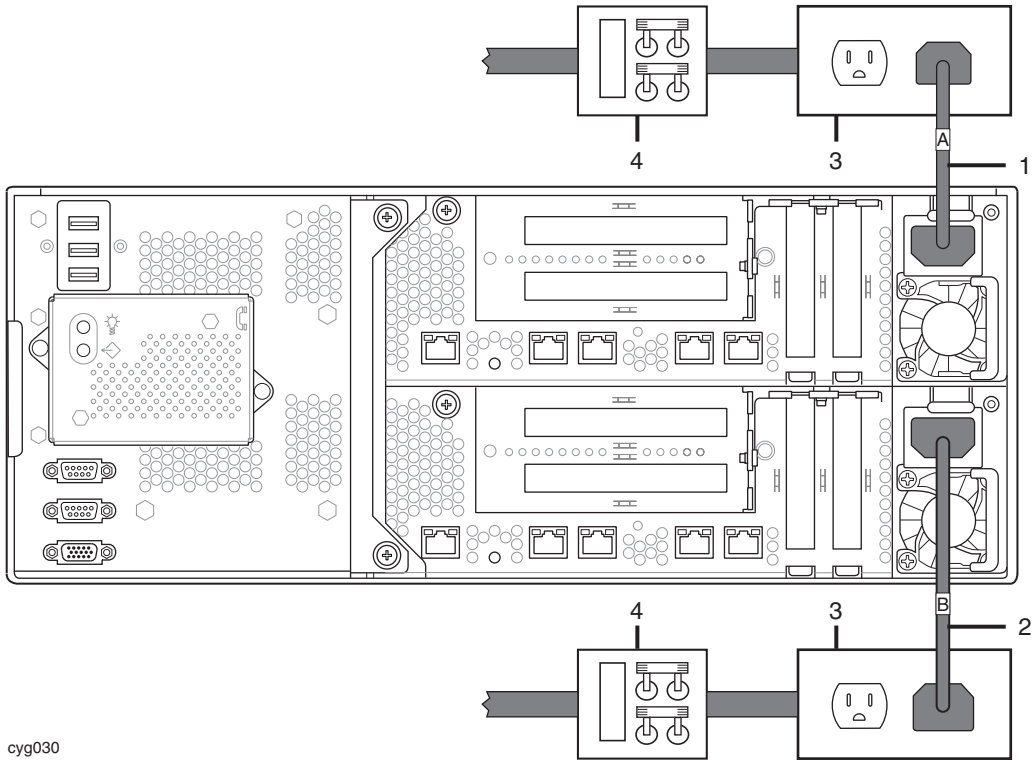

cyg030

- |  |   |
|--|---|
| <ul style="list-style-type: none"> <li>1 A-side power cord</li> <li>2 B-side power cord</li> </ul> | <ul style="list-style-type: none"> <li>3 AC power outlets</li> <li>4 Circuit breakers (maximum of 20A)</li> </ul> |
|--|---|

Figure 2-2. PDUs Connected Directly to AC Power

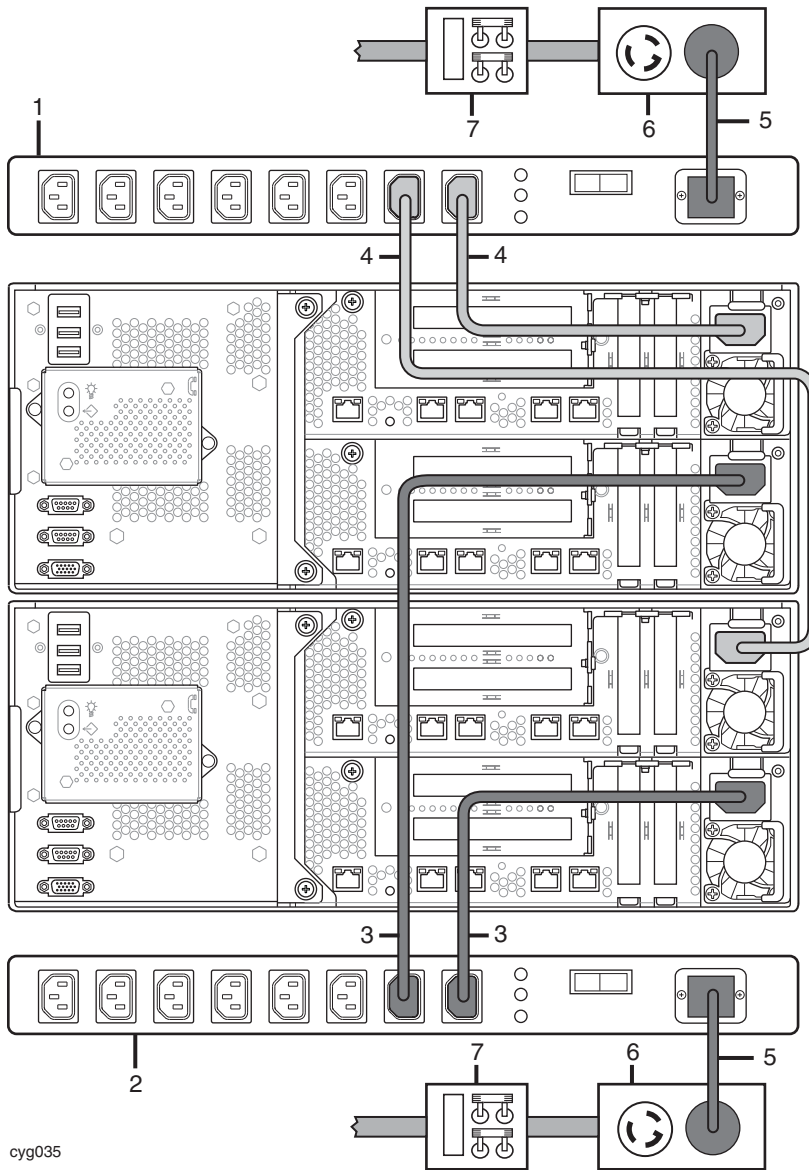

cyg035

- |   |                      |   |                                   |
|---|----------------------|---|-----------------------------------|
| 1 | A-side PDU           | 5 | PDU power cords                   |
| 2 | B-side PDU           | 6 | AC power outlets                  |
| 3 | B-side jumper cables | 7 | Circuit breakers (maximum of 20A) |
| 4 | A-side jumper cables |   |                                   |

## Selecting a UPS Unit for ftServer Systems

Stratus does not sell or service UPS units. However, Stratus has qualified UPS models for use with ftServer 27x0, 47x0, and 64x0 systems.

Use [Table 2-1](#) to determine the number of watts the A-side of your system requires, and then see [http://stratadoc.stratus.com/genref/refsell/qualified\\_equipment.html](http://stratadoc.stratus.com/genref/refsell/qualified_equipment.html) to select an appropriate UPS model.

### NOTES

---

1. Connect only one ftServer system directly to each qualified UPS. Connecting multiple ftServer systems or any peripheral components (for example, monitors, tape drives, storage systems, or Fibre Channel switches) to a Stratus-qualified UPS is not supported because these UPS models are sized only for the ftServer system.
2. If you need to provide battery backup for peripheral components, plan for additional UPS capacity to handle the load of these components, and test your configuration to ensure that it works properly when power is removed. If you need assistance in planning and testing your UPS configuration, contact the Stratus Customer Assistance Center (CAC) or your authorized Stratus service representative.
3. Site planning information for the UPS in this document and on the Stratus Web site are of a general nature only. Do not rely exclusively on this information. Contact APC at <http://www.apc.com> for detailed UPS specifications, documentation, sizing, and ordering information.

## Communicating with a UPS over a Network

Use the following additional tools to enable a UPS and an ftServer system to communicate over the network:

- APC UPS Network Management Card 2 (APC part number AP9630)
- APC PowerChute® Network Shutdown for the ftServer system

When you install your ftServer system, download PowerChute Network Shutdown from APC, and install and configure the tool on the system, as described in *Stratus Automated Uptime Layer for Windows-based ftServer Systems: Installation and Configuration* (R002W) or *Stratus Automated Uptime Layer for VMware*

*vSphere-based ftServer Systems: Installation and Configuration (R004E).*  
 PowerChute Network Shutdown monitors the UPS for an imminent power loss, and initiates an orderly shutdown of the system before power is lost.

## Connecting a System Directly to a UPS

You can connect the A-side power connectors of your system directly to a UPS, as shown in [Figure 2-3](#).

**Figure 2-3. Rack-Mountable Systems: A-Side Power Connected Directly to a UPS**

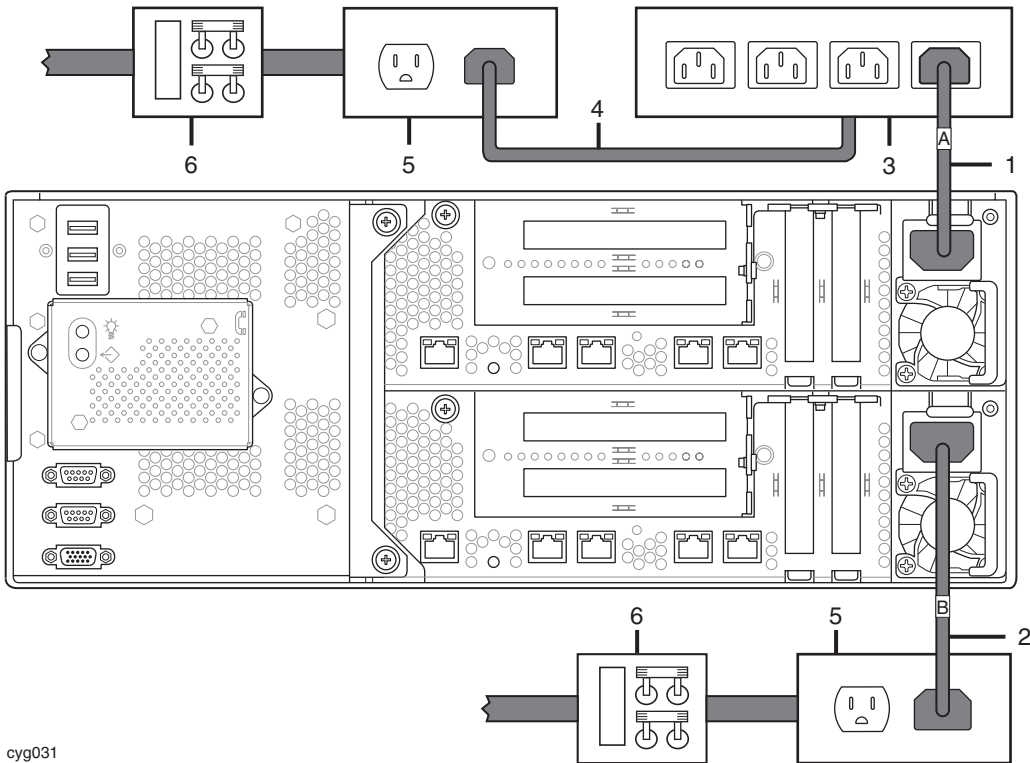

cyg031

- |   |                          |   |                                   |
|---|--------------------------|---|-----------------------------------|
| 1 | A-side system power cord | 4 | UPS power cord                    |
| 2 | B-side system power cord | 5 | AC power outlets                  |
| 3 | UPS                      | 6 | Circuit breakers (maximum of 20A) |

## Power Cord Summary

Stratus supplies tested and approved AC power cords for the following components:

- [ftServer systems and peripheral components](#)
- PDUs



### WARNING

Place all power cords out of the way of foot traffic.



### AVERTISSEMENT

Éloigner tous les cordons d'alimentation du passage.

Power cords described as Domestic are made with American Wire Gauge (AWG) cordage and are intended for use in North America. Refer to UL 62 and CSA C22.2, No. 49. All other power cords are made with International cordage and are intended for use in the specified countries, and other countries that use that standard.

## Power Cords for ftServer Systems and Peripheral Components

[Table 2-9](#) lists the available power cords that connect ftServer systems and peripheral components directly to an AC power source (not to a PDU or to a UPS).

[Table 2-10](#) lists the available power cords that connect ftServer systems to [qualified UPS models](#) from APC.

**Table 2-9. Power Cords - ftServer Systems and Peripheral Components to AC Power**

| Marketing ID | Plug Type                                    | Rating   | Length         | Locale                   |
|--------------|--|----------|----------------|--------------------------|
| B50101F      | NEMA 5-15, UL/CSA approved, to IEC 60320 C13 | 15A/127V | 7 ft (2.1m)    | North America (Domestic) |
| B50104F-P    | NEMA 5-15, UL/CSA approved, to IEC 60320 C13 | 15A/127V | 15 ft (4.6m)   | North America (Domestic) |
| B50112F      | CEE 7 VII to IEC 60320 C13                   | 16A/250V | 14.8 ft (4.5m) | Europe (Continental)     |
| B50116F      | BS 1363/A to IEC 60320 C13                   | 13A/250V | 14.8 ft (4.5m) | United Kingdom           |
| B50124F      | AS/NZS 3112:1993 to IEC 60320 C13            | 10A/250V | 14.8 ft (4.5m) | Australia                |

**Table 2-9. Power Cords - ftServer Systems and Peripheral Components to AC Power (Continued)**

| Marketing ID | Plug Type                                    | Rating   | Length         | Locale  |
|--------------|--|----------|----------------|---|
| B50140F      | SEV 1011-S24507 to IEC 60320 C13             | 10A/250V | 14.8 ft (4.5m) | Switzerland                                   |
| B50152F      | SABS164-1:1992 ZA/3 to IEC 60320 C13         | 13A/250V | 14.8 ft (4.5m) | South Africa/India                            |
| B50153F      | IEC 60309, TUV approved, to IEC 60320 C13    | 16A/250V | 14.8 ft (4.5m) | International, locking power cord             |
| B50160F-P    | NEMA 5-15, PSE approved, to IEC 60320 C13    | 15A/127V | 15 ft (4.6m)   | Japan (100V applications)                     |
| B50161F-P    | NEMA L6-20, UL approved, to IEC 60320 C13    | 20A/250V | 15 ft (4.6m)   | North America, locking power cord             |
| B50162F      | GB1002-1996, CCC approved, to IEC 60320 C13  | 10A/250V | 8 ft (2.4m)    | China   |
| B50173F      | NEMA 5-15, BSMI approved, to IEC 60320 C13   | 10A/125V | 14.8 ft (4.5m) | Taiwan  |
| B50174-P     | L6-20P, PSE approved, to IEC 60320 C13       | 15A/250V | 15 ft (4.6m)   | Japan, locking power cord (200V applications) |
| B50176       | IEC60227, Inmetro approved, to IEC 60320 C13 | 10A/250V | 14.8 ft (4.5m) | Brazil  |

## PDU Power Cords

**Table 2-10. Power Cords Between ftServer Systems or Storage Systems and a UPS**

| Marketing ID | Plug Types                             | Rating   | Length         | Locale  |
|--------------|--|----------|----------------|---|
| B50104F-P    | NEMA 5-15 to IEC 60320 C13             | 15A/127V | 15 ft (4.6m)   | North America                                 |
| B50160F-P    | NEMA 5-15 to IEC 60320 C13             | 15A/127V | 15 ft (4.6m)   | Japan   |
| B50161F-P    | NEMA L6-20 to IEC 60320 C13            | 20A/250V | 15 ft (4.6m)   | North America, locking power cord             |
| B50301F-P    | IEC 60320 C14 to IEC 60320 C13         | 10A/250V | 14.8 ft (4.5m) | International                                 |
| B50174-P     | L6-20P, PSE approved, to IEC 60320 C13 | 15A/250V | 15 ft (4.6m)   | Japan, locking power cord (200V applications) |

The PDU supplies power to ftServer systems. [Table 2-11](#) lists the available power cords that connect PDUs directly to an AC power source.

[Table 2-12](#) describes the gray and black power (*jumper*) cables that are provided to connect ftServer systems to PDUs.

**Table 2-11. Power Cords to Connect PDUs Directly to AC Power Mains**

| Marketing ID | Plug Type                                  | Rating   | Length       | Locale                   |
|--------------|--|----------|--------------|--------------------------|
| B50154F      | IEC 60320 C19 to IEC 60309                 | 20A/250V | 15 ft (4.6m) | International            |
| B50171F      | IEC 60320 C19 to NEMA L6-20P, PSE approved | 16A/250V | 15 ft (4.6m) | North America            |
| B50175       | IEC 60320 C19 to NEMA L6-20P, PSE approved | 20A/250V | 15 ft (4.6m) | Japan locking power cord |

**Table 2-12. System Power (*Jumper*) Cables to Connect ftServer Systems to PDUs**

| Marketing ID | Plug Type to System | Plug Type to PDU | Rating   | Length      |
|--------------|---------------------|------------------|----------|-------------|
| B50502F      | IEC 60320 C13       | IEC 60320 C14    | 10A/250V | 6.6 ft (2m) |
| B50503F      | IEC 60320 C13       | IEC 60320 C14    | 10A/250V | 6.6 ft (2m) |

## Grounding Requirements



### **WARNING** \_\_\_\_\_

**Incorrect grounding can cause severe personal injury and extensive equipment damage.**



### **AVERTISSEMENT** \_\_\_\_\_

**Une mise à la terre incorrecte peut provoquer des blessures graves et endommager sérieusement l'équipement.**

The ftServer system obtains its protective earth (PE) ground through the power cord.

See [“Grounding Considerations” on page B-1](#) for a more complete discussion of ftServer system grounding.



---

## Chapter 3

# Space Planning

For information about planning sufficient space for your ftServer system, see:

- [“Room Requirements” on page 3-1](#)
- [“Planning for Cables” on page 3-3](#)

## Room Requirements

To ensure that the installation site provides a properly equipped, cooled, and sized environment, make sure that the site:

- Provides clearances for air circulation, opening cabinet doors, removing cabinet panels, and servicing the system from the front and rear.  
Locate the front and rear of the system at least 2.5 feet (ft) (0.76 meters (m)) away from walls and other obstructions.
- Maintains reasonable temperature and humidity levels and has a thermometer and humidistat to monitor room temperature and humidity.  
See [Chapter 2](#) for detailed information about HVAC planning and [Appendix A](#) for detailed information about temperature and humidity requirements.
- Is as free as possible of airborne contamination (particulate and gaseous).



### CAUTION

---

Due to the mission-critical nature of Stratus servers, data centers housing the equipment should follow the guidelines of airborne contamination (particulate and gaseous) as outlined in the ASHRAE (TC) 9.9 documentation. Particulate matter to adhere to ISO 14644-1 Class 8. Gaseous contamination, such as sulfur or chlorine-bearing gases to adhere to ANSI/ISA-71.04-1985 Severity level G1.



### **MISE EN GARDE** \_\_\_\_\_

En raison de la nature stratégique des serveurs Stratus, les centres de données hébergeant l'équipement doivent respecter les directives relatives à la contamination atmosphérique (particulaire et gazeuse), tel qu'indiqué dans la documentation 9.9 de l'ASHRAE (TC). Les particules doivent adhérer à la norme ISO 14644-1 Classe 8. La contamination gazeuse, comme les gaz chlorés ou sulfurifères, doit adhérer à la norme ANSI/ISA-71.04-1985 avec un niveau de sévérité G1.

Dust buildup in the system can impede air circulation and heat transfer, causing components to become less reliable as the ambient temperature rises.

Fans clogged by dust fail to expel hot air, causing circuit boards to overheat and fail.

Dust on circuit boards raises the temperature, thus reducing the component's mean time between failure (MTBF).

Dust circulating in the room increases the risk of fire within the room by providing potential combustible material within the environment.

Dust contamination on tape devices causes mis-reads and -writes, leading to failure of attempts to back up and restore data.

- Has sufficient floor space for external components.
- Provides a table or desktop for external devices such as a telephone, external monitor, keyboard, and mouse.

Each of these devices requires table or rack space.



### **CAUTION** \_\_\_\_\_

You cannot place a peripheral component on top of a system cabinet.



### **MISE EN GARDE** \_\_\_\_\_

Vous ne pouvez pas placer un composant périphérique sur le dessus de l'armoire d'un système.

- Allows the system and peripheral devices to be placed within the room so that power cords and communications cables will reach their respective power receptacles, telephone jacks, and other connection points.

- Provides communications cable connectors or patch panels as needed.
- Provides two electrically separate grounded AC wall outlets, within reach of the power cords from the system or PDUs, and, if used, UPS units. Detachable power cords are 15 ft. (4.5m). If the power cord must be hard-wired, consult an electrician to plan the length of the power cord.
- Provides grounded AC wall outlets for external components that do not connect to a PDU.
- Provides cutouts in the floor for routing cables, if the site has an elevated floor.
- Contains space for future expansion.

**CAUTION** \_\_\_\_\_

Do not place the system in an area of high electrostatic discharge. Static electricity may damage components. Do not locate components near transformers or other electromagnetic devices.

**MISE EN GARDE** \_\_\_\_\_

Ne pas placer le système dans une zone de décharge électrostatique élevée. L'électricité statique peut endommager les composants. Ne pas placer les composants à proximité de transformateurs ou d'autres appareils électromagnétiques.

See [Appendix A](#) and the *Stratus ftServer Systems: Peripherals Site Planning Guide (R582)* for the dimensions of system components.

## Planning for Cables

To accommodate cables from your system, make sure to provide:

- One or two telephone lines:
  - One telephone line for use when calling for service
  - One telephone line for the ASN modem, if used
- Ethernet jacks, switches, or hubs, as needed
- Two electrically separate grounded AC wall outlets, or a UPS and a wall outlet, within reach of the power cords from the system or PDUs, and additional outlets for any components that do not connect to a PDU
- For optional components, AC wall outlets within reach of the power cords from the components, or use PDUs

Make sure that cables you plan to connect to the system are long enough to reach between the system and external components or connections. For information about specific cables and power cords, see the following:

- [“Power Cord Summary” on page 2-11](#)
- [Chapter 4, “Communications Line Planning”](#)
- [“Monitor Requirements” on page 6-5](#)
- *Stratus ftServer Systems: Peripherals Site Planning Guide (R582)* for information about cable lengths for peripheral components

---

# Chapter 4

## Communications Line Planning

Make sure that you plan the locations of your ftServer system and its external components so that all communications and data cables will reach their connection points.

This chapter contains the following sections:

- “Supported Host Bus Adapters” on page 4-2
- “Connections from Storage Systems to ftServer Systems” on page 4-2
- “Ethernet Cables” on page 4-5
- “Telephone Line Connections” on page 4-8

### NOTES

---

1. If you have a unique network requirement, contact the Stratus Customer Assistance Center (CAC) or your authorized Stratus service representative. For more information about the CAC, see [Getting Help](#) in the Preface or the <http://www.stratus.com/go/support> Web site.
2. See the *Stratus ftServer Systems: PCI Adapter Guide* (R461) for more information about the adapters Stratus supplies for your ftServer system.

## Supported Host Bus Adapters

[Table 4-2](#) summarizes the host bus adapters (HBAs) supported by ftServer 27x0, 47x0, and 64x0 systems.

You must provide your own cables, with one exception: two 2-meter 50/125  $\mu\text{m}$  (micrometer) OM3 multi-mode fiber (MMF) dual-fiber cables with LC-type connectors (part number AW-B91000-020) are included with each ftScalable Storage G2 system.

See the *Stratus ftServer Systems: PCI Adapter Guide* (R461) for information about PCI-Express adapters.

## Connections from Storage Systems to ftServer Systems

ftServer systems support both Fibre Channel (FC) connections and Internet SCSI (iSCSI) connections to storage systems. For more information, see the following sections:

- [“Fibre Channel Connections” on page 4-2](#)
- [“iSCSI Connections” on page 4-4](#)

### Fibre Channel Connections

ftServer systems support FC connections to first-generation ftScalable Storage and ftScalable Storage G2 systems, and to EMC CLARiiON and Symmetrix storage systems. Optical FC HBAs in the CPU- I/O enclosures provide connection points to these storage enclosures.

#### NOTE

Follow EMC's RPQ process for approval before attaching EMC storage systems to VMware vSphere-based ftServer systems.

Windows-based ftServer systems have the following FC connection options:

- Directly attach the FC cables between one or two ftServer systems and the RAID controller trays of an ftScalable Storage G2 system.
- Connect the FC cables from one or two ftServer systems directly to an EMC storage system (for Windows-based systems only).
- Connect multiple ftServer systems to first-generation ftScalable Storage systems or ftScalable Storage G2 systems through a storage area network (SAN).
- Connect up to six ftServer systems to EMC storage systems through a SAN.

VMware vSphere-based systems have the following FC connection options:

- Directly attach the FC cables between a single ftServer system and the RAID controller trays of an ftScalable Storage G2 system.
- Connect multiple ftServer systems to first-generation ftScalable Storage or ftScalable Storage G2 systems through a storage area network (SAN).
- Connect up to six ftServer systems to EMC storage systems through a SAN.

A pair of optical FC HBAs provides fault tolerance through the multipath I/O capability of the operating system. The adapters are single-ported, and each member of the pair is installed in a different CPU-I/O enclosure: one in the top enclosure and the other in the bottom enclosure. The *Stratus ftServer Systems: Peripherals Site Planning Guide* (R582) lists the supported optical FC HBAs.

[Table 4-1](#) lists the optical FC cables available for connecting U107 PCIe adapters. The cable sets come in blue and yellow, to make it easy to distinguish between members of cable pairs. See the *Stratus ftServer Systems: PCI Adapter Guide* (R461) for information about cables for connecting U107 PCIe adapters.

**Table 4-1. Optical FC Cables**

| Length         | Part number<br>Blue Cables | Part number<br>Yellow Cables |
|----------------|----------------------------|------------------------------|
| 0.98 ft (0.3m) | AW-B91000-003              | AW-B91001-003                |
| 1.64 ft (0.5m) | AW-B91000-005              | AW-B91001-005                |
| 6.5 ft (2m)    | AW-B91000-020              | AW-B91001-020                |
| 32.8 ft (10m)  | AW-B91000-100              | AW-B91001-100                |
| 98.4 ft (30m)  | AW-B91000-300              | AW-B91001-300                |

For detailed information about making the FC connections, see one of the following:

- *ftScalable Storage: Getting Started Guide* (R601)
- *ftScalable Storage G2: Getting Started Guide* (R651)
- The documentation for your EMC storage system

The cabling diagrams shown in the *ftScalable Storage: Getting Started Guide* (R601) and the *ftScalable Storage G2: Getting Started Guide* (R651) show FC connections, in both direct-attach (DAS) and storage-area-network (SAN) configurations, from ftServer systems to ftScalable Storage G2 and first-generation ftScalable Storage systems. (Connections to EMC storage systems through a SAN are similar.)

Specifically, see the following figures:

- In the *ftScalable Storage G2: Getting Started Guide* (R651):
  - “Single-Host DAS Connections”
  - “Multi-Host DAS Connections”
  - “Dual-Host SAN Connections”
- In the *ftScalable Storage: Getting Started Guide* (R601):
  - “SAN Connections Between a First-Generation ftScalable Storage System and a Newer Model ftServer System”
  - “Single-Host DAS Connections Between a First-Generation ftScalable Storage System and a Newer Model ftServer System (VMware vSphere-based Systems)”

## iSCSI Connections

ftServer 27x0, 47x0, and 64x0 systems support iSCSI connections to ftScalable Storage G2 systems and to EMC CLARiiON storage systems.

### NOTES

---

1. iSCSI connections to first-generation ftScalable Storage systems are not supported.
2. Follow EMC's RPQ process for approval before attaching EMC storage systems to VMware vSphere-based ftServer systems.
3. Ensure that your ftServer system provides adequate bandwidth for your iSCSI storage requirements.
4. ftServer systems support only software iSCSI initiators in conjunction with standard network adapters. Hardware iSCSI HBAs are not supported. Contact your account representative for information about third-party iSCSI storage systems qualified for use with ftServer systems.

Each ftServer system must contain two available Ethernet adapters (one in each CPU-I/O enclosure). You can use embedded Ethernet adapters or U105 Dual-Port 10/100/1000 Base-T Ethernet PCI-Express Adapters, or for better performance, use U584 Dual-Port Fiber 10-Gigabit Ethernet PCI-Express Adapters. See the *Stratus ftServer Systems: PCI Adapter Guide* (R461) for additional information about supported Ethernet adapters.



For optimal performance and reliability with the U584 PCIe adapter, use only 50/125 micrometer ( $\mu\text{m}$ ) MMF (multi-mode fiber) dual-fiber cable rated with the OM3 performance code. With this type of cable and a 10-Gb link established, the maximum distance between the PCI adapter and an Ethernet hub or a switch is 984 feet (ft) or 300 meters (m).

For cabling diagrams and detailed information about making the iSCSI connections to ftScalable Storage G2 systems, see the *ftScalable Storage G2: Getting Started Guide* (R651). For information about making the iSCSI connections to EMC CLARiiON storage systems, see the *Stratus ftServer 27x0, 47x0, and 64x0 Systems: Installation Guide* (R668).

## Ethernet Cables

In addition to the Ethernet cables listed in this section, you must also plan to provide network connection points. Consider providing a network connection with Internet access for each of the VTMs to allow you and, if authorized, the CAC or your authorized Stratus service representative to access the VTMs' Web interface to operate the system and diagnose problems remotely. If available, this mode of accessing the VTMs is faster and more reliable than dialup through the ASN modem.



### WARNING

**Make sure network cables can be routed out of the way of foot traffic.**



### AVERTISSEMENT

**Vérifier que les câbles réseau peuvent être acheminés en dehors du passage.**

You will need Ethernet cables for the following connections:

- From embedded Ethernet ports on the system and Ethernet ports on U105 PCIe adapters and U584 PCIe adapters to network connection points. See [“Planning for Network Connectivity” on page 1-4](#) for information about the number and types of embedded Ethernet ports available on each system.

### NOTES

1. Two Ethernet ports are typically paired and teamed in software for fault tolerance. Each member of the pair requires an Ethernet cable.
2. If your system contains embedded 10-GbE ports, see [“Category-6/Category-6A Cables” on page 4-7](#) for additional site-planning information.

- From each first-generation ftScalable Storage or ftScalable Storage G2 RAID controller tray, if present, to a network connection point, for Web management and monitoring of ftScalable Storage systems
- From a management PC to a network connection point, for Web management of ftScalable Storage systems

The same network must provide access to the RAID controllers on the first-generation ftScalable Storage or ftScalable Storage G2 RAID controller tray from the PC.

Table 4-2 describes the cables you must supply for network connectivity. Be sure to provide cables of sufficient length for the distance between the system and a wall jack or hub.

**Table 4-2. Customer-Supplied Ethernet Cables**

| Component  | Quantity  | Marketing ID/Cable Length   | Cable Type  |
|--|---|---|---|
| VTM Ethernet Port  | 2   | N/A. You must supply these cables.<br><br>The maximum allowable distance from these ports to a switch or a hub is 328 ft (100m).  | 24 AWG Unshielded Twisted Pair (UTP) EIA/TIA-Verified, Category-3 or Category-5 wire, with RJ-45 modular connectors terminated with pair-wiring adhering to the EIA/TIA 568-A or EIA/TIA 568-B standard.<br><br>For connections to an Ethernet hub or switch, provide a straight-through cable.<br><br>For 100- or 1000-Mbps (fast Ethernet) operation, provide full-duplex, or Category-5 Ethernet cables. |
| 1-GbE Embedded Ethernet Port   | 4   |   |   |
| U105 Dual-Port Copper 10/100/1000 Base-T Ethernet PCI-Express Adapter (gigabit copper adapter for servers) | 1 for each port, typically teamed for fault tolerance |   |   |
| 10-GbE Embedded Ethernet Port  | 4   | N/A. You must supply these cables.<br><br>The maximum allowable distance from these ports to a switch or a hub is 328 ft (100m) for Category-6A wire, and 180 ft (55m) for Category-6 wire. | 22 AWG Unshielded Twisted Pair (UTP) EIA/TIA-Verified, Category-6 or Category-6A wire, with RJ-45 modular connectors terminated with pair-wiring adhering to the TIA/EIA-568-B.2-10 standard  |

**Table 4-2. Customer-Supplied Ethernet Cables** (Continued)

| Component  | Quantity   | Marketing ID/Cable Length  | Cable Type   |
|--|--|--|--|
| U584 Dual-Port Fiber 10-Gigabit Ethernet PCI-Express Adapter   | 1, typically teamed for fault tolerance                    | N/A. You must supply this cable.<br><br>With the specified type of cable and a 10-Gb link established, the maximum distance between the PCI adapter and an Ethernet hub or a switch is 984 ft (300 m). | Multi-mode fiber (MMF), 50/125 $\mu$ m dual-fiber cable rated with the OM3 performance code, with LC-type connectors to the PCI adapter, and connectors on the other end that are compatible with your site network switch.  |
| ftScalable Storage RAID controller tray (note that first-generation ftScalable Storage and ftScalable Storage G2 systems are optional) | 3: two for each controller tray and one to a management PC | N/A. You must supply these cables.   | 24 AWG Unshielded Twisted Pair (UTP) EIA/TIA-Verified, Category-3 or Category-5 wire, with RJ-45 modular connectors terminated with pair-wiring adhering to the EIA/TIA 568-A or EIA/TIA 568-B standard.<br><br>For connections to an Ethernet hub or switch, provide a straight-through cable.<br><br>For 100-Mbps (fast Ethernet) operation, provide full-duplex, or Category-5 Ethernet cables. |

## Category-6/Category-6A Cables

If your system contains embedded 10-GbE ports using Category-6/Category-6A cables, additional site planning is needed to prevent disruptions from electromagnetic interference (EMI).

- Between devices, try to have as close as possible to zero (0) volt potential relative to earth reference ground. See [“Grounding Considerations” on page B-1](#) for detailed information.
- Separate all power cords from the cables.
- Do not route the cables near fluorescent lights.
- Ground the cable trays.
- Avoid using two-way radios and cell phones near the cables.

- If your site is located near high electric fields, transmission towers, high-voltage transmission lines, or electrical switching relays, consider using shielded Category-6A cable.

See the following standards for more information about Category-6A cables and how to qualify a test site:

- The ANSI/TIA-568 family of Telecommunications Standards (C.0, C.1, C.2, C.3)
- TIA/EIA-607: Grounding and Bonding Requirements for Telecommunications in Commercial Buildings

## Telephone Line Connections

The system requires up to two telephone cables, and related connection points:

- One telephone line for use when calling for service
- One analog telephone line to connect the ASN modem, if used, to a telephone connection point

A 7-ft (2.13m) telephone cable (minimum 26 AWG phone cord) is shipped with the modem assembly.<sup>1</sup>

### NOTE

---

A dedicated phone line provides the most reliable service for ASN connections. ASN calls routed through a PBX might be slow due to the load on the PBX, or might not complete successfully because the calls can become disconnected. If you must use a PBX, do not route the telephone extension through a switchboard; instead, provide a direct-dial analog number.

- Always use telephone cable that is 26 AWG or greater and is UL approved.

If no modem is installed, a second telephone line is not necessary. A modem is not necessary if your system will connect to a network with Internet access. You may choose to use the Internet to send alarms to the ASN and allow the CAC or your authorized Stratus service representative to connect to your system over the Internet for troubleshooting.

---

<sup>1</sup> The telephone cable is not shipped with orders destined for the Republic of Korea.

## **Modem Requirements for Brazil**

The ANATEL mark for telecom is required in Brazil. The Multi-Tech<sup>®</sup> modem located in the Stratus ASN modem assembly does not have this agency mark. Therefore, Stratus **cannot** ship this modem to Brazil.

## **Modem Requirements for Belarus**

The STB mark for telecom is required in Belarus. The Multi-Tech modem located in the Stratus ASN modem assembly does not have this agency mark. Therefore, Stratus **cannot** ship this modem to Belarus.

## **Modem Requirements for Kazakhstan**

The GOST-K mark for telecom is required in Kazakhstan. The Multi-Tech modem located in the Stratus ASN modem assembly does not have this agency mark. Therefore, Stratus **cannot** ship this modem to Kazakhstan.



---

# Chapter 5

## Rack Configuration Planning

For information about planning a rack configuration, see:

- [“Using PDUs” on page 5-1](#)
- [“Determining PDU Requirements” on page 5-2](#)
- [“Example of PDU Usage Calculation” on page 5-4](#)

### Using PDUs

Server systems have two power receptacles. Correspondingly, two power distribution units (PDUs) provide power to the receptacles.

Use of PDUs is optional unless you have a support agreement with Stratus. If you do have a support agreement with Stratus, use pairs of PDUs to provide AC power to systems and components in a cabinet **if six or more power cords would otherwise exit from the cabinet.**

The A-side (top) PDU provides power to:

- The A-side of each system
- A rack-mounted LCD monitor unit
- A storage enclosure
- Any rack-mounted tape drives

The B-side (bottom) PDU provides power to the other side of each system and to the second side of a storage enclosure.

Because the A-side PDU always uses at least as many power cords and consumes at least as much power as the B-side PDU, plan the cabinet configuration so that the A-side PDU can support the configuration.

NOTES \_\_\_\_\_

1. Connect each PDU to a separate AC power source.
2. Install a maximum of two pairs of PDUs in a rack.

Use the information in [“Determining PDU Requirements” on page 5-2](#) to plan the rack configuration for your ftServer system. [“Example of PDU Usage Calculation” on page 5-4](#) shows how to use the information you gather for planning the rack configuration.



**CAUTION** \_\_\_\_\_

For important safety information about your PDUs, see [“PDU Safety Considerations” on page B-10](#).



**MISE EN GARDE** \_\_\_\_\_

Pour obtenir des informations importantes sur la sécurité de vos unités de distribution de l'alimentation, consultez la section [“PDU Safety Considerations” on page B-10](#).

## Determining PDU Requirements

Using the nominal voltage rating of the power receptacle at your site and the total wattage of the components that will draw power from the A-side PDU, complete the information in [Tables 5-1 and 5-2](#). This information will help you determine the current that the ftServer systems and rack-mounted components will draw and whether you need a second pair of PDUs.

### To complete [Table 5-1](#)

1. Obtain the voltage available at your location. Consult a facilities manager at your site to make sure you know the correct voltage.
2. For each type of component you plan to place in the rack, calculate the required current, as follows: Divide the wattage of the element, listed in the Watts column of [Table 5-1](#), by the voltage available at your site. Multiply the result by 1.25 and enter the value in the **Current** column.



**Table 5-1. Current and Rack-Space Requirements**

| Component                           | Watts | ÷ | Site Voltage <sup>†</sup> | x 1.25 = | Current (A) | Rack Space |
|-------------------------------------|-------|---|---------------------------|----------|-------------|------------|
| ftServer system                     | 700   | ÷ |                           | x 1.25 = |             | 4U         |
| 1U LCD monitor unit <sup>‡</sup>    |       | ÷ |                           | x 1.25 = |             | 1U         |
| Tape-drive enclosure <sup>§</sup>   |       | ÷ |                           | x 1.25 = |             |            |
| Disk-storage enclosure <sup>‡</sup> |       | ÷ |                           | x 1.25 = |             |            |

<sup>†</sup> PDU input voltage is 200-240 VAC.

<sup>‡</sup> See the *Stratus ftServer Systems: Peripherals Site Planning Guide* (R582) for the wattage and rack requirements of your monitor and disk-storage solutions.

<sup>§</sup> See your tape-drive documentation for the wattage and rack requirements of your tape drive.

### To complete [Table 5-2](#)

1. In column 1, write the names of each system or component in the rack. If you have more than one system, use a row for each system.
2. In column 2, write the cumulative number of rack units (Us): Add the number of Us (see [Table 5-1](#)) for the component to the value in the space above and write the result.
3. In column 3, write the cumulative number of outlets required. For each component, add 1 to the value in the space above and write the result.
4. In column 4, write the cumulative current required. For each component, add the current for the component, which you entered in [Table 5-1](#), to the value in the space above and write the result.

You need another pair of PDUs if the cumulative number of outlets exceeds 8 or if the cumulative current exceeds 15A. Use the information in column 2 to plan the size and number of racks required.



**Table 5-4. Example: Calculating A-Side PDU and Rack-Space Requirements**

| 1. Component                 | 2. Cumulative Space Used (U) | 3. Cumulative Number of A-Side Outlets | 4. Cumulative Current (A) |
|------------------------------|------------------------------|--|---------------------------|
| PDU pair                     | 2                            | 0                                      | 0.00                      |
| ftServer system              | 6                            | 1                                      | 4.21                      |
| 1U LCD monitor unit          | 7                            | 2                                      | 4.53                      |
| Tape drive (typical)         | 9                            | 3                                      | 5.01                      |
| ftScalable Storage G2 system | 11                           | 4                                      | 7.63                      |
| ftServer system              | 15                           | 5                                      | 11.84                     |
| PDU pair                     | 2                            | 0                                      | 0                         |
| ftServer system              | 6                            | 1                                      | 4.21                      |
| ftServer system              | 10                           | 2                                      | 8.42                      |

In the calculations in [Table 5-4](#), components were added one by one, calculating:

- The total current demanded by the components
- The total space used in the rack
- The total number of outlets required

In this example, two PDUs can provide enough current for two ftServer 27x0, 47x0, or 64x0 systems, the LCD monitor unit, one tape drive (typical), and one ftScalable Storage G2 system. This set of components consumes 11.84 amperes; adding another ftServer system would increase the consumption to 16.05 amperes, which exceeds the 15 amperes limit for the PDUs. The configuration also utilizes 5 outlets in the A-side PDU and 15U of rack space.

To add any more components, you require another pair of PDUs.

For information about planning a rack configuration, see:

- [“Using PDUs” on page 5-1](#)
- [“Determining PDU Requirements” on page 5-2](#)
- [“Example of PDU Usage Calculation” on page 5-4](#)



---

## Chapter 6

# Cabinet and Monitor Requirements

For requirements related to providing your own cabinet and monitor, see:

- [“Cabinet Requirements” on page 6-1](#)
- [“Monitor Requirements” on page 6-5](#)

### Cabinet Requirements

If you are providing your own cabinet for an ftServer system, make sure the cabinet contains a rack that is 19 inches (in.) wide and that meets the Electronic Industries Association (EIA) 310-D Section 1 standard.

In general, consider the following factors during your site planning for systems in cabinets:

- **Elevated Operating Ambient Temperature**—If installed in a closed or multi-unit rack assembly, the operating ambient temperature of the rack environment may be greater than room ambient. Therefore, consideration should be given to installing the equipment in an environment compatible with the maximum ambient temperature (T<sub>ma</sub>) specified by the manufacturer.
- **Reduced Air Flow**—Installation of the equipment in a rack should be such that the amount of air flow required for safe operation of the equipment is not compromised.
- **Mechanical Loading**—Mounting of the equipment in the rack should be such that a hazardous condition is not achieved due to uneven mechanical loading.
- **Circuit Overloading**—Consideration should be given to the connection of the equipment to the supply circuit and the effect that overloading of the circuits might have on overcurrent protection and supply wiring. Appropriate consideration of equipment nameplate ratings should be used when addressing this concern.
- **Reliable Earthing**—Reliable earthing of rack-mounted equipment should be maintained. Particular attention should be given to supply connections other than direct connections to the branch circuit (for example, use of power strips).

Make sure that the cabinet meets the following requirements:

- The cabinet can support the weight of all of the components you plan to install in it. [Appendix A](#) and the *Stratus ftServer Systems: Peripherals Site Planning Guide* (R582) provide the weights of components supplied by Stratus.
- The cabinet contains two front and two rear vertical EIA rails, one in each corner of the cabinet, that have the **universal** square-hole pattern as defined in the EIA 310-D Section 1 specification.
- The front vertical rails extend at least 0.5 in. (1.27 centimeters (cm)) beyond the inside edge of the accessory leg, if present, to allow the mounting rails to be fitted. See [Figure 6-1](#).
- The distance between the front vertical rails and the inside of the front door is at least 3.0 in. (7.62 cm).
- The distance between the rear of the system chassis and the inside of the rear door is at least 6.0 in. (15.24 cm).
- The distance between the front and rear vertical rails is between 24.5 in. and 30 in. (62.23 cm and 76.20 cm, respectively).
- The vertical mounting rails have a 0.345" or 0.375" square pattern, with a thickness between 0.063" - 0.105", to accept 10-32 cage nuts and mounting hardware.
- The vertical mounting rails are plated, or some other method is used to ensure continuity for grounding between installed equipment.
- Cable-management brackets are provided to support and constrain data and power cords so that the cables do not interfere with air flow out of the rear of the enclosures, and so that the connectors do not disconnect or break.
- To prevent stray voltages, all components are grounded together through the vertical mounting rails to the cabinet frame, and then to local building ground. To ensure signal quality, use a grounding cable for local building ground.
- There is a plan for maintaining cables and wires to the cabinet by either running them under the floor or placing them overhead in an overhead cable tray.
- Air flows through the cabinet from front to back.
- Air does not recirculate within the cabinet.
- Filler panels cover any unused rack space to prevent air recirculation.
- Blockers are installed between the vertical mounting rails and the side panels at the rear of the cabinet.
- Vents are evenly distributed on the front and rear doors and make up at least 69% of the surface area.

NOTE \_\_\_\_\_

If your cabinet does not have vented front and rear doors, you can remove the doors from the cabinet while your ftServer system is operating.

- The final installation conforms to all emission, immunity, safety, and other applicable regulations.

Figure 6-1 shows the required rail clearance between the front vertical rails and the inside edge of an accessory leg.

Figure 6-1. Rail Clearance

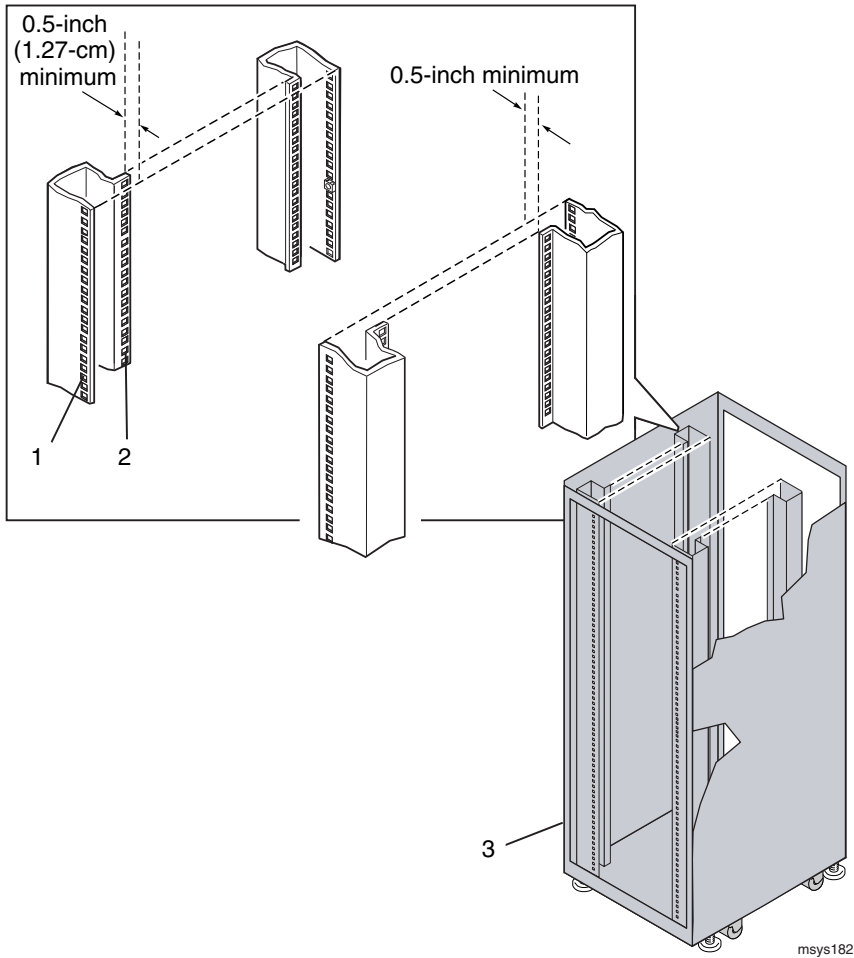

- 1 Front vertical EIA rail
- 2 Accessory leg
- 3 Front of cabinet

msys182



## Monitor Requirements

If you are using a monitor that is not supplied by Stratus, make sure that:

- The monitor accepts universal 100–240 volts AC (VAC), 50/60 Hertz (Hz) power.
- The VGA cable has a 15-pin D-sub connector.
- The power cord for the monitor is long enough to reach the power source.
- The plug type on the power cord is compatible with the external power source at the site.



---

# Appendix A

## System Specifications

For system specifications, see:

- [“System Specifications” on page A-1](#)
- [“PCIe Adapter Specifications” on page A-7](#)
- [“AAP87600 PDU Specifications” on page A-8](#)

### NOTES

---

1. The system temperature and humidity requirements defined in [Table A-2](#) are the **minimum** requirements the site must provide.
2. The temperature and humidity requirements for optional components are provided in the *Stratus ftServer Systems: Peripherals Site Planning Guide (R582)*.

## System Specifications

The following figures show front and rear views of the systems.

- [Figure A-1](#) shows the front of an ftServer 27x0, 47x0, or 64x0 system, mounted in a rack with its bezel pulled forward.
- [Figure A-2](#) shows the rear of a rack-mountable ftServer 27x0, 47x0, or 64x0 system, specifying the locations of the connectors at the rear of the system.

[Table A-1](#) lists the dimensions of the system cabinets supplied by Stratus. [Table A-2](#) lists the specifications for each ftServer CPU-I/O enclosure, the front panel, and the backplane assembly. [Table A-4](#) lists the specifications of the PDU. See the *Stratus ftServer Systems: Peripherals Site Planning Guide (R582)* for the specifications of other components.

**Figure A-1. ftServer 27x0, 47x0, 64x0 System: CPU-I/O Enclosures: Front View**

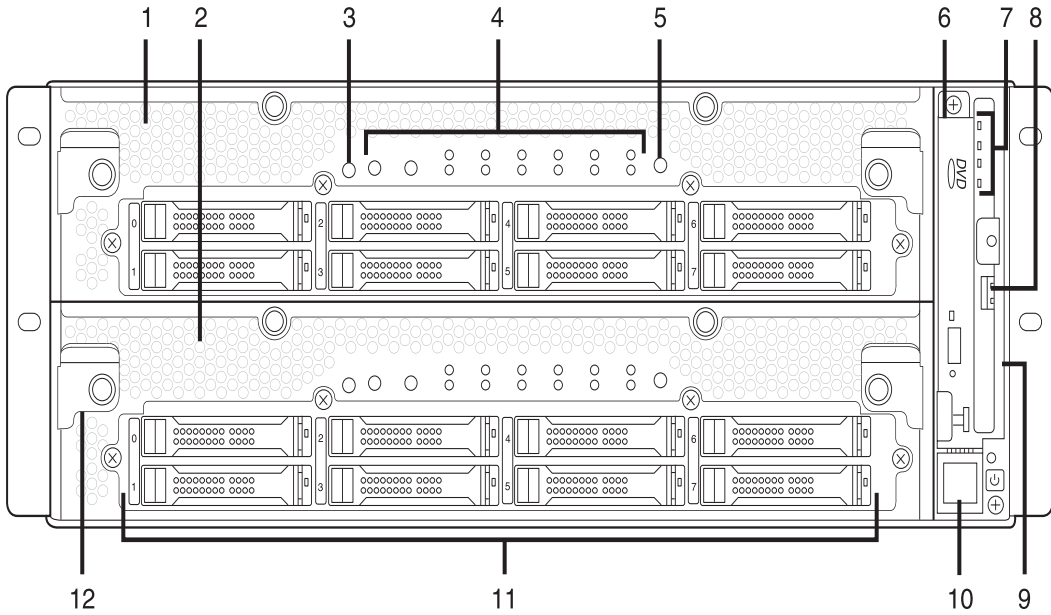

dco001b

- |   |                                       |    |  |
|---|---------------------------------------|----|--|
| 1 | CPU 0, I/O 10                         | 7  | Front panel LEDs                               |
| 2 | CPU 1, I/O 11                         | 8  | USB port                                       |
| 3 | CPU ID button (magnifying glass icon) | 9  | Front panel                                    |
| 4 | System LEDs                           | 10 | Power button                                   |
| 5 | NMI (dump) button                     | 11 | Internal disk drives (16) or disk drive blanks |
| 6 | DVD drive                             | 12 | Release levers (4)                             |

Figure A-2. ftServer 27x0, 47x0, 64x0 System: Rear View

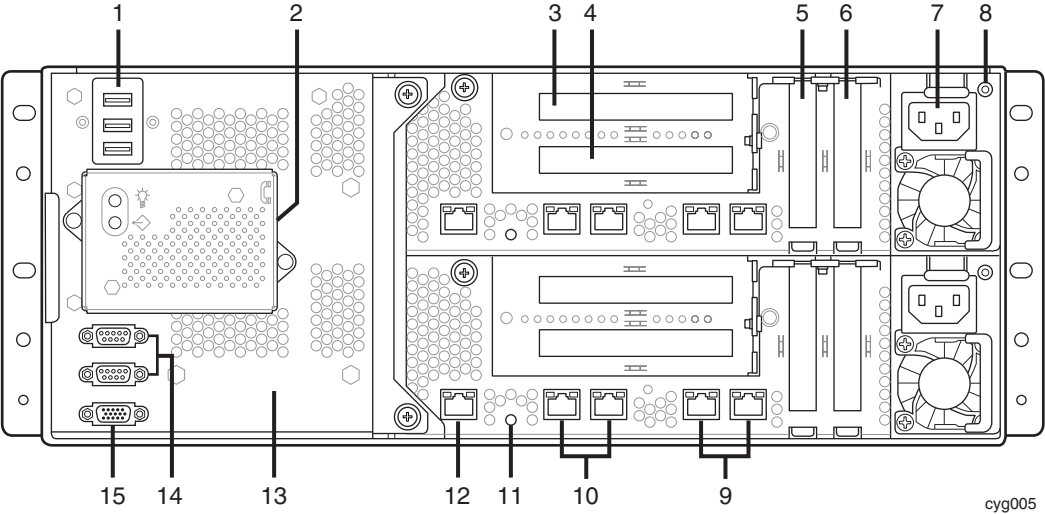

- 1 USB ports (3)
- 2 Modem and telephone port<sup>†</sup>
- 3 PCI adapter slot 3 (PCIe full-height)<sup>‡</sup>
- 4 PCI adapter slot 4 (PCIe full-height)<sup>‡</sup>
- 5 PCI adapter slot 1 (PCIe, low profile)
- 6 PCI adapter slot 2 (PCIe, low profile)
- 7 Power receptacles (2)
- 8 Power supply LEDs (2)
- 9 Embedded 1GbE ports (4)
- 10 Embedded 10GbE Ethernet ports (4)<sup>‡</sup>
- 11 CPU-I/O enclosure blue identification LEDs (2)
- 12 VTM Ethernet ports (2)
- 13 System backplane
- 14 Serial (COM) ports (2)
- 15 VGA (monitor) port

<sup>†</sup> The telephone port is available only when the optional modem is installed.  
<sup>‡</sup> Not available on ftServer 27x0 systems or on ftServer 47x0 systems without PCIe risers.

Table A-1. Cabinet Dimensions

|                               |                |
|-------------------------------|----------------|
| <b>24U Shipping Container</b> |                |
| Height (including pallet)     | 56 in. (1.42m) |
| Width                         | 41 in. (1.04m) |
| Depth                         | 53 in. (1.35m) |
| <b>38U Shipping Container</b> |                |
| Height (including pallet)     | 80 in. (2.03m) |

**Table A-1. Cabinet Dimensions (Continued)**

|  |                    |
|--|--------------------|
| Width  | 41 in. (1.04m)     |
| Depth  | 53 in. (1.35m)     |
| <b>24U Cabinet</b>                               |                    |
| Height (including casters)                       | 49.5 in. (1.26m)   |
| Width  | 27.6 in. (70 cm)   |
| Depth  | 41 in. (1.04m)     |
| Weight, empty                                    | 280 lb (127 kg)    |
| Weight, empty with pallet and shipping container | 436 lb (197.8 kg)  |
| Weight capacity (payload)                        | 1500 lb (680.4 kg) |
| <b>38U Cabinet</b>                               |                    |
| Height (including casters)                       | 74 in. (1.9m)      |
| Width  | 27.5 in. (70 cm)   |
| Depth  | 41 in. (1.04m)     |
| Weight, empty (with front and rear doors)        | 350 lb (158.76 kg) |
| Weight, empty with pallet and shipping container | 512 lb (232.2 kg)  |
| Weight capacity (payload)                        | 1500 lb (680.4 kg) |

**Table A-2. ftServer 27x0, 47x0, 64x0 System Unit Specifications**

| <b>Power</b>  |  |
|---|--|
| Input power   | 700W for each enclosure (1400W total)  |
| Nominal input voltage   | 100-127 or 200-240 volts; 50/60 Hz   |
| Power Factor  | 0.98   |
| VA  | 960 (240V x 4A)<br>700 (100V x 7A)   |
| Protective earth ground current   | 3.5 mA maximum for each AC power cord  |
| <b>Physical Dimensions</b>  |  |
| Height  | 7.0 in. (17.78 cm; 4U)   |
| Width   | 17.50 in. (44.45 cm)   |
| Depth   | 30.1 in. (76.5 cm), with modem and bezel, excluding rail   |
| Weight (fully-loaded, with 2 processors, 16 DIMMs, and 8 disks per CPU-I/O enclosure) | System (2 CPU-I/O enclosures, shelf unit, front panel, backplane, and bezel): 120 lb (54.4 kg)<br><br>Mounting brackets: 3 lb (1.4 kg)         |
| <b>Environmental</b>  |  |
| Operating temperature   | 41° F to 95° F (5° C to 35° C)<br>For every 800 ft (243.8 m) above 2000 ft (609.6 m), lower the maximum operating temperature by 34° F (1° C). |
| Storage temperature   | -38° F to 140° F (-39° C to 60° C), vented   |
| Operating altitude  | 0 ft to 10,000 ft (0m to 3,048m). In China markets, regulations may limit installations to a maximum altitude of 6562 ft (2000m).              |
| Maximum rate of temperature change during operation                                   | 54° F (12° C) per hour   |
| Relative humidity during operation  | 10% to 80% (noncondensing)   |
| Relative humidity during storage  | 5% to 95% (noncondensing)  |

**Table A-2. ftServer 27x0, 47x0, 64x0 System Unit Specifications (Continued)**

|   |  |
|---|--|
| Heat dissipation, each system (both enclosures) | 4774 BTUs per hour   |
| Air cleanliness                                 | Meets ISO 14644-1 class 8 standards  |
| <b>Features</b>                                 |  |
| Processors                                      | <p>ftServer 2700: One Intel® Sandy Bridge-EP Quad-Core 1.8 GHz processor in each CPU-I/O enclosure</p> <p>ftServer 2710: One Intel Ivy Bridge-EP six-Core 2.0 GHz processor in each CPU-I/O enclosure</p> <p>ftServer 4700: Two Intel Sandy Bridge-EP Quad-Core 1.8 GHz processors in each CPU-I/O enclosure</p> <p>ftServer 4710: One Intel Ivy Bridge-EP 10-Core 2.5 GHz processor in each CPU-I/O enclosure</p> <p>ftServer 6400: Two Intel Sandy Bridge-EP Octa-Core 2.6 GHz processors in each CPU-I/O enclosure</p> <p>ftServer 6410: Two Intel Ivy Bridge-EP 20-Core 2.5 GHz processors in each CPU-I/O enclosure</p> |
| Memory  | 16 physical, fully buffered (FB) DDR3 inline memory module (DIMM) slots in each CPU-I/O enclosure. All 16 slots are usable in dual-processor systems. Only 8 slots are usable in single-processor systems.   |
| Ports   | <p>Two embedded 1-gigabit Ethernet (GbE) ports in each CPU-I/O enclosure</p> <p>Two embedded 10GbE ports in each CPU-I/O enclosure on ftServer 64x0 and 47x0 systems; however, on ftServer 47x0 systems, these ports are operational only if the system contains the optional PCIe riser. These ports are not available on ftServer 27x0 systems.</p> <p>Two AC power connectors, one VGA port, two serial ports, and four USB ports† (three on the system backplane and one on the front panel)</p>   |
| PCIe slots (standard)                           | <p>Two low-profile PCI-Express slots standard on each CPU-I/O enclosure</p> <p>See <a href="#">“PCIe Adapter Specifications”</a> for details.</p>  |



**Table A-2. ftServer 27x0, 47x0, 64x0 System Unit Specifications (Continued)**

|                            |  |
|----------------------------|--|
| Additional PCI slots       | <p>On ftServer 64x0 systems, each CPU-I/O enclosure supports one PCIe riser with two full-height-capable PCIe slots.</p> <p>On ftServer 47x0 systems, the PCIe riser is optional.</p> <p>The PCIe riser is not supported on ftServer 27x0 systems.</p> <p>See <a href="#">“PCIe Adapter Specifications”</a> for details.</p>   |
| BMC                        | <p>One advanced system management module (Baseboard Management Controller, or BMC) embedded in each CPU-I/O enclosure with one 10/100-Mbps Ethernet port dedicated to the BMC in each CPU-I/O enclosure. BMCs include embedded Virtual Technician Module (VTM) functionality.</p>  |
| Internal disk drives       | <p>Up to eight Serial Attached SCSI (SAS) disks per CPU-I/O enclosure.</p> <ul style="list-style-type: none"> <li>• For internal hard disk drives, up to eight per CPU-I/O enclosure are supported.</li> <li>• For enterprise flash drives (EFDs), up to four per CPU-I/O enclosure are supported. However, you can combine EFDs with hard disk drives for a total of eight drives per CPU-I/O enclosure.</li> </ul> |
| DVD+/-R drive <sup>†</sup> | <p>In the front panel, one drive that reads from CDs and DVDs.</p>   |

<sup>†</sup> VMware vSphere-based ftServer systems support the DVD drive and other USB devices only during system software installation.

## PCIe Adapter Specifications

Two PCIe slots are standard on each CPU-I/O enclosure motherboard. In addition, a PCIe riser that adds two slots per enclosure is standard on ftServer 64x0 systems and optional on ftServer 47x0 systems. (The PCIe riser is not available on ftServer 27x0 systems.) [Table A-3](#) lists the power and length specifications for PCI adapters.

**Table A-3. PCIe Adapter Specifications**

|   |  |
|---|--|
| <b>Power</b>  |  |
| PCI slot rating   | 10W maximum per PCI slot   |
| <b>Physical Dimensions</b>  |  |
| CPU-I/O enclosure mother board  | Two low-profile PCIe slots<br>6.6 in (167.64 mm) maximum adapter length  |
| PCIe riser (standard on ftServer 64x0 systems; optional on ftServer 47x0 systems) | Two full-height-capable PCIe slots<br>Top riser slot (PCI 3): 6.6 in. (167.64 mm) maximum adapter length<br>Lower riser slot (PCI 4): 6.6 in. (167.64 mm) maximum adapter length |

Use only Stratus-approved PCI adapters in your Stratus system. Before approving an adapter, Stratus thoroughly tests it to make sure that it interacts properly with Stratus systems, including failover to a duplexed partner if an active adapter or CPU-I/O enclosure fails or is removed from service. Customers who have attempted to use inadequately tested PCI adapters in their systems have frequently experienced problems that proved difficult to isolate and diagnose and resulted in delayed projects.

Stratus provides ftReady third-party PCI adapter testing and driver hardening services. To find out more about these offerings, contact the Stratus Customer Assistance Center (CAC) or your authorized Stratus service representative (see [Getting Help](#) in the Preface or the <http://www.stratus.com/go/support> Web site).

You should thoroughly test any new PCI adapter, including adapters sold or approved by Stratus, with your applications in a test environment before using it in a production environment.

All Stratus-approved PCI adapters are submitted for Electromagnetic Interference (EMI) and safety compliance. Other adapters will not have EMI and safety approvals for use in an ftServer system.

## AAP87600 PDU Specifications

A power distribution unit (PDU) optionally supplies power to rack-mounted ftServer systems and optional rack-mountable components.

**CAUTION**

For important safety information about your PDUs, see [“PDU Safety Considerations” on page B-10](#).

**MISE EN GARDE**

Pour obtenir des informations importantes sur la sécurité de vos unités de distribution de l'alimentation, consultez la section [“PDU Safety Considerations” on page B-10](#).

[Figure A-3](#) shows the AAP87600 PDU.

**Figure A-3. AAP87600 PDU**

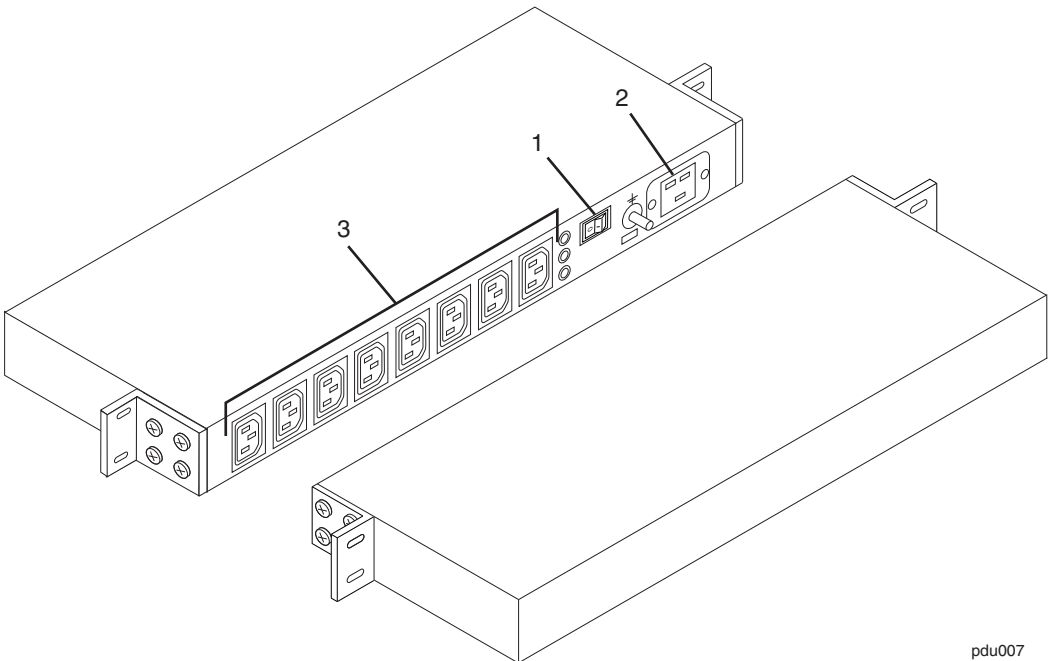

pdu007

- 1 Circuit breaker switch
- 2 AC input receptacle
- 3 AC outlet receptacles

[Table A-4](#) lists the specifications for the AAP87600 PDU.

**Table A-4. AAP87600 PDU: Specifications**

| <b>Input Specifications</b>                         |   |
|---|---|
| Power input   | Single phase, AC  |
| Nominal input voltage; frequency                    | 200–240 VAC; 50/60 Hz   |
| Current <sup>†</sup>                                | 16 amps   |
| Input receptacle                                    | IEC 320/C20   |
| Input protection <sup>‡</sup>                       | 16A, circuit breaker  |
| Power dissipation <sup>§</sup>                      | 10W nom. @ 240 VAC  |
| Panel indicators <sup>¶</sup>                       | LED, main, and TVS  |
| <b>Output Specifications</b>                        |   |
| Power output <sup>††</sup>                          | 3.84 KVA, maximum   |
| Output receptacle                                   | 8x - IEC 320/C13  |
| PE ground <sup>‡‡</sup>                             | 1/4" - 20 threaded stud   |
| <b>Physical and Environmental Specifications</b>    |   |
| Overall size <sup>§§</sup>                          | Height: 1.72 in. (4.36 cm)<br>Width: 19.0 in. (48.26 cm)<br>Depth: 6.5 in. (16.51 cm)   |
| Weight  | 5.7 lb (2.6 kg)   |
| Operating temperature during operation              | 32° F (0° C) to 131° F (55° C)<br><br>For every 800 ft (243.8m) above 2000 ft (609.6m), lower the maximum operating temperature (95° F (35° C)) by 1.8° F (1° C). |
| Maximum rate of temperature change during operation | 54° F (12° C) per hour or 32.36° F (0.2° C) per minute  |
| Relative humidity during operation                  | 10% to 80% (noncondensing)  |
| Storage temperature to 40,000 ft (12.2 km)          | -38° F to 140° F (-40° C to 60° C)  |
| Relative humidity during storage                    | 5% to 95% (noncondensing)   |

† Denotes a maximum continuous input current of 16A at 250 VAC.

‡ The circuit breaker is UL 489-listed and features a flat rocker front surface with an "Accidental Off" feature. The circuit breaker has a delay curve similar to an AIRPAX™ LEG series, delay 62.

§ *Power dissipation* is the combination of heat loss due to wiring, input filter leakage, and LED indicators.

¶ LEDs are turned off when TVS networks are disconnected from the circuitry because of overheating caused by transient voltage conditions.

†† Output power is the combined power of the 8 outlets, which averages 2 amps/outlet at 240 VAC.

‡‡ Denotes Protective Earth Ground.

§§ Overall size includes the width of the mounting flanges. The PDU cabinet is sized for EIA 19 in. (48.26 cm) rack installation.



---

# Appendix B

## Electrical Circuit and Wiring Information

For electrical circuit and wiring information that you need to provide to the contractor and/or facilities personnel responsible for wiring the power at the system installation site, see:

- [“Fault Protection Requirements” on page B-1](#)
- [“Grounding Considerations” on page B-1](#)
- [“Circuit Wiring Diagrams” on page B-2](#)
- [“Electrical Power Connectors” on page B-9](#)
- [“PDU Safety Considerations” on page B-10](#)

### Fault Protection Requirements

Each enclosure in ftServer systems contains internal fault/overload current protection. However, the system relies on the power distribution system at your site for protection against potential faults in the power cords and the wiring in the system base.

System and PDU power cords must not be connected to a branch circuit greater than 20A.

### Grounding Considerations

The system obtains an earth reference ground through the power cords attached to the system. Similarly, each peripheral device connected to the system obtains ground through its power cord. You **must** ensure that a high-integrity safety-ground conductor is installed as part of the wiring system (in accordance with U.S. national electric code NFPA 70 or the equivalent). The international safety standard (EN60950) for electronic data processing (EDP) equipment also requires a ground conductor, but calls it a protective earth (PE) ground.

Depending upon local conditions, ground potentials may differ between the system base and any peripheral devices connected to the system base. All grounds in the system **must** return to the same reference point in the power distribution system, as close as possible to **zero (0) volt potential** relative to earth reference ground. Earth reference ground is typically a metal stake in the ground to which the ground conductors from one or more buildings are attached.

As shown in [Figure B-1](#), a *star ground* is often used to obtain the same earth reference ground. Each earth reference ground, such as the system base ground, is returned separately to a common point where a zero-volt (0V) earth ground exists. The star ground ensures that all equipment is at the same potential and that no noise or safety problems associated with an unpredictable or uncharacterized grounding system will occur.

**Figure B-1. Star Ground Example**

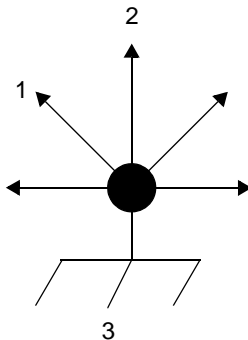

- 1 To monitor
- 2 To ftServer system
- 3 Earth reference ground (0V)

## Circuit Wiring Diagrams

The following circuit wiring diagrams show how the hot, ground, and/or neutral AC signals should be connected to the power input plugs of the system and optional components:

- [Figure B-4](#) illustrates a single-phase 120V AC circuit connection.
- [Figure B-5](#) illustrates a single-phase 240V AC circuit connection.
- [Figure B-6](#) illustrates a split-phase 120/240V AC circuit connection.
- [Figure B-7](#) illustrates a three-phase 208V AC, Y-, or  $\Delta$ -source circuit connection, phase-to-phase.
- [Figure B-8](#) illustrates a three-phase 380V AC, Y-, or  $\Delta$ -source circuit connection, phase-to-neutral.

In the following diagrams, the power inputs for ftServer 27x0, 47x0, and 64x0 systems are labeled X and Y, as shown in [Figure B-2](#) and [Figure B-3](#), to eliminate any ambiguities in the nomenclature. For single-phase applications, the X input is



connected to the L (Line) *hot* input, and the Y input is connected to the N (Neutral) input. However, for split-phase or three-phase applications, the X and Y inputs are connected to L1, L2, or L3 (separate lines). Therefore, for split-phase or three-phase applications, both X and Y can be electrically hot with respect to the system base (earth reference ground). [Figure B-2](#) shows the physical locations of the X and Y inputs on the PDU, and [Figure B-3](#) shows them on the system enclosure.

**Figure B-2. PDU Power Input Labeling**

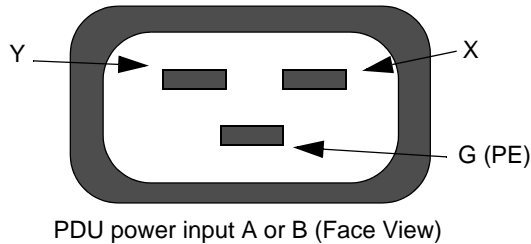

**Figure B-3. ftServer Enclosure Power Input Labeling**

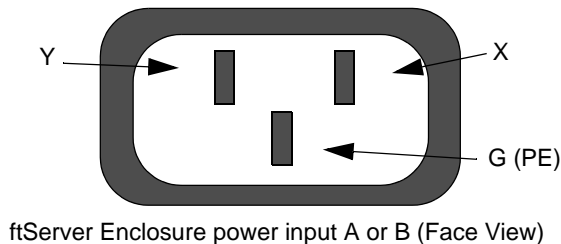

Figure B-4 shows a single-phase 120V AC circuit connection. Note that this application requires a single-pole circuit breaker.

**Figure B-4. Single-Phase 120V AC Circuit Connection**

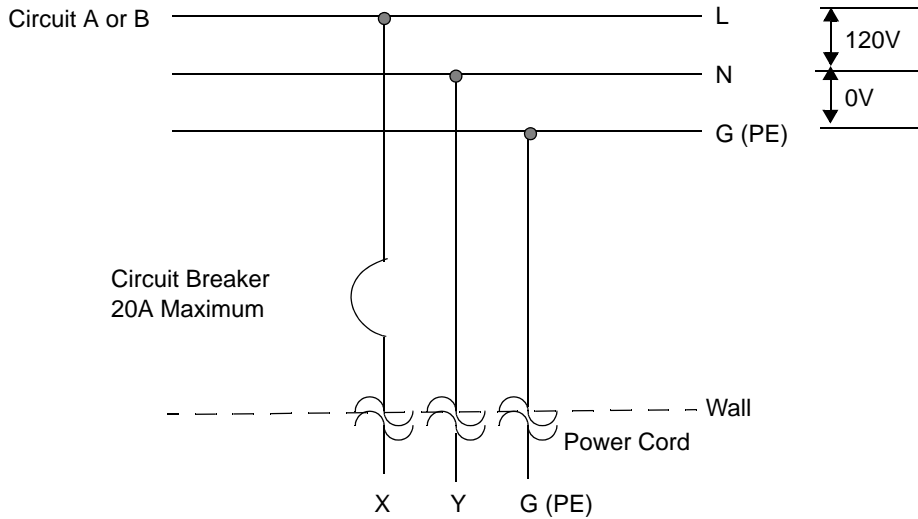

Figure B-5 shows a single-phase 240V AC circuit connection. Note that this application requires a single-pole circuit breaker.

**Figure B-5. Single-Phase 240V AC Circuit Connection**

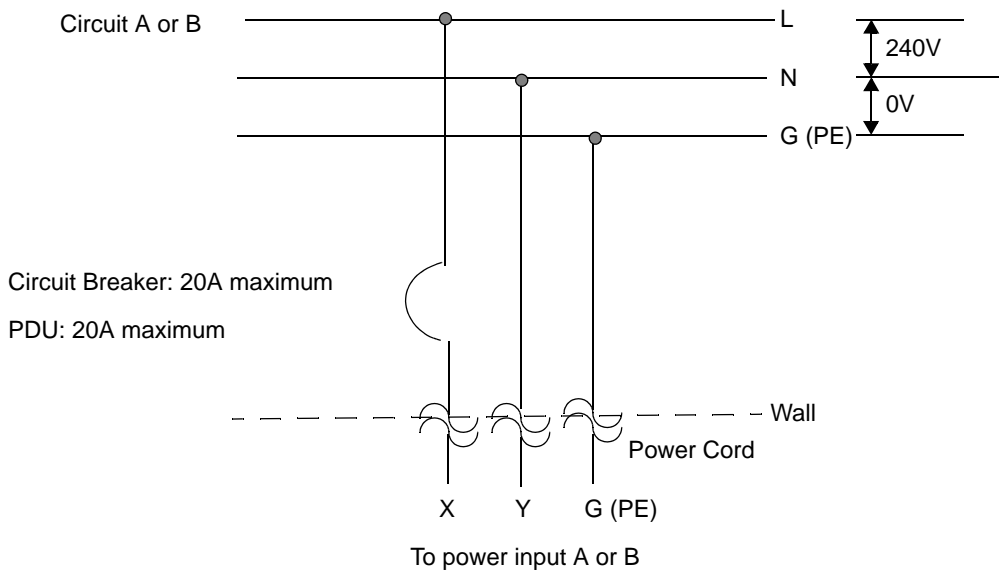

Figure B-6 shows a split-phase 120/240V AC circuit connection. Note that this application requires a double-pole circuit breaker.

Figure B-6. Split-Phase 120/240 Volts AC Circuit Connection

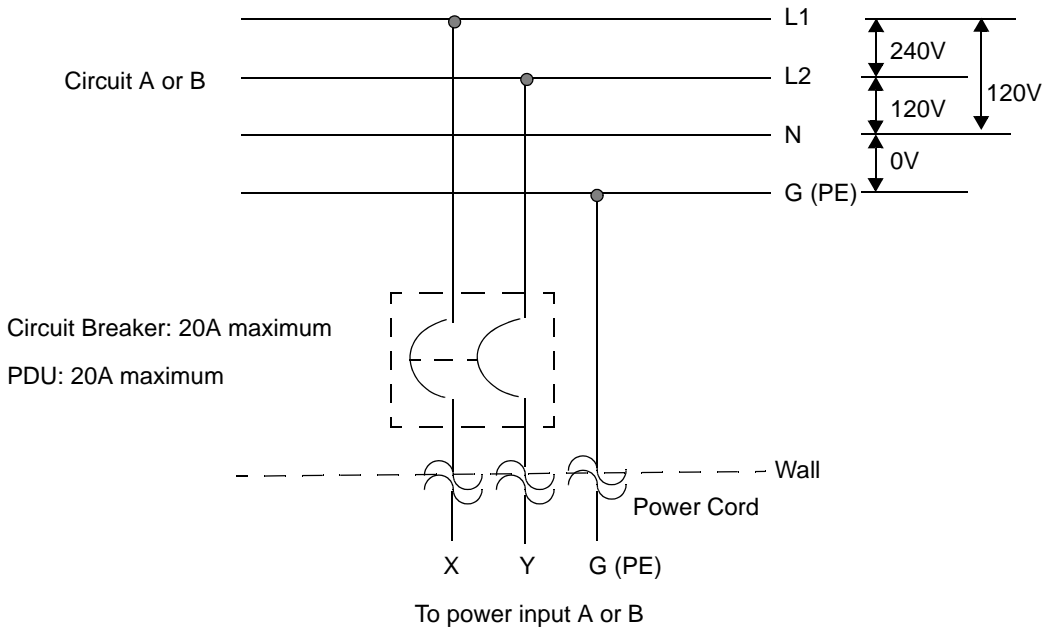

Figure B-7 shows a three-phase 208V AC, Y-, or  $\Delta$ -source circuit connection, which is a phase-to-phase source connection. Note that the X and Y inputs on the system can be connected from L1 and L2, L2 and L3, or L1 and L3. This application requires a double-pole circuit breaker.

**Figure B-7. Three-Phase 208V AC, Y-, or  $\Delta$ -Source Circuit Connection, Phase-to-Phase**

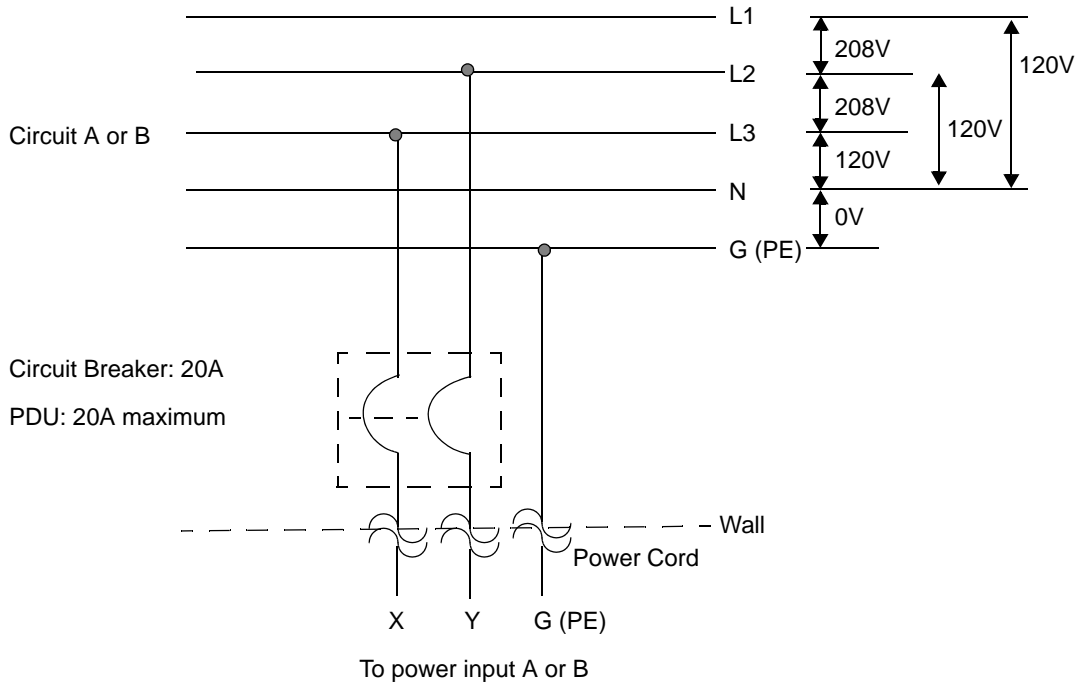
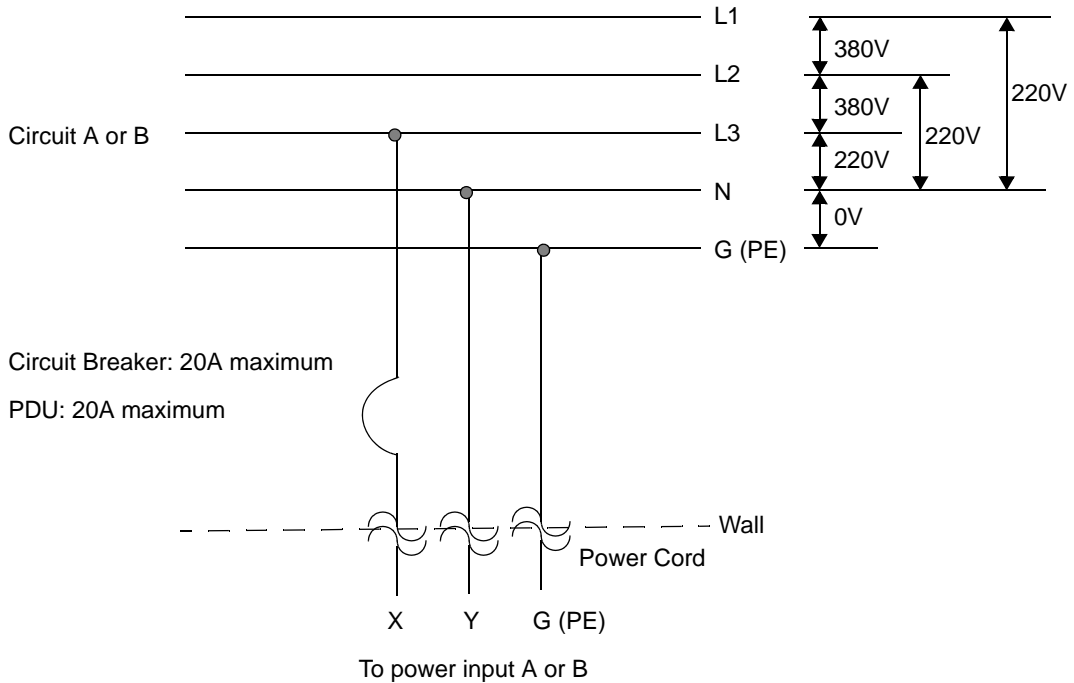

Figure B-8 shows a three-phase 380V AC, Y-, or  $\Delta$ -source circuit connection, which is a phase-to-neutral source connection. Note that the system's X input can be connected to L1, L2, or L3. This application requires a single-pole circuit breaker.

**Figure B-8. Three-Phase 380V AC, Y-, or D-Source Circuit Connection, Phase-to-Neutral**



## Electrical Power Connectors

Table B-1 describes the connectors required by the AC power cords that Stratus supplies with ftServer systems and optional devices.

**Table B-1. Connectors for AC Power Outlets**

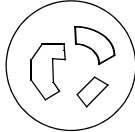
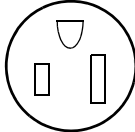
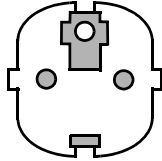
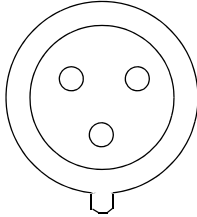
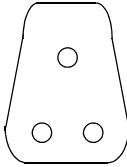
| Connector                          | Configuration   | Rating               | Description    |
|------------------------------------|---|----------------------|----------------|
| NEMA L6-20                         |    | 20A, 250 volts AC    | 2-pole, 3-wire |
| NEMA 5-15                          |    | 15A, 125 volts AC    | 2-pole, 3-wire |
| CEE (7) VII                        |    | 20A, 250 volts AC    | 2-pole, 3-wire |
| IEC 60309<br>(formerly<br>IEC 309) |  | 16-20A, 250 volts AC | 2-pole, 3-wire |
| SABS<br>164-1:1992                 |  | 16A, 250 volts AC    | 2-pole, 3-wire |

**Table B-1. Connectors for AC Power Outlets (Continued)**

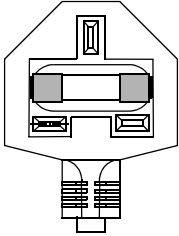
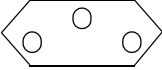
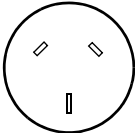
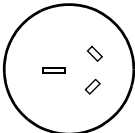
| Connector                 | Configuration  | Rating            | Description    |
|---------------------------|--|-------------------|----------------|
| BS 1363/A                 |   | 13A, 250 volts AC | 2-pole, 3-wire |
| SEV 1011-S24507           |   | 10A, 250 volts AC | 2-pole, 3-wire |
| SAA/3/15 AS/NZS 3112-1993 |   | 15A, 250 volts AC | 2-pole, 3-wire |
| GB1002-1996               |  | 10A, 250 volts AC | 2 pole, 3-wire |

## PDU Safety Considerations

This section describes some important safety considerations for PDUs.

A PDU provides for the reliable distribution of power via eight outlets. When installed into a standard EIA 19-inch data, security, or industrial control rack, the PDU provides up to 3.84 kilowatts of filtered power to the system.

The PDU's input is filtered to reduce emissions in Information Technology (IT) applications and provides at least 30 decibels of common-mode noise reduction. It provides even greater differential noise reduction between the frequency ranges of 1 to 10 MHz. In addition, the PDU contains thermally protected transient voltage suppression (TVS) networks, which clamp common mode and differential mode voltage transients with up to 170 joules of energy content. The PDU is also equipped



with LEDs that are lit green if the main power input is present and if the TVS networks are ready and functional.

Transient voltages are unpredictable. The amount of energy associated with them varies greatly depending on amplitude and duration. This PDU with its 170-joule rating is designed to be effective at the equipment rack level. It should be part of a layered protection system, coordinated with higher energy-level protective devices such as AC distribution TVS devices, UPS systems with TVS devices, and building-level protective devices, including active or passive devices such as isolation transformers. In the event of a high voltage transient, the PDU TVS network will activate, clamping the voltage to protect the load. Based on the amplitude and duration of these abnormal events, higher source currents can trip the branch circuit breaker, leaving the PDU without an input source.

**NOTE** \_\_\_\_\_

TVS devices have a finite life expectancy and wear out when subjected to input voltage transients. If either LED is off, the PDU's transient protection is not guaranteed and you should replace the PDU.

Be careful when specifying amperage and delay parameters for the branch circuit breaker that provides power to the PDU. Selection of circuit breakers in an electrical power system should be specified so that when an abnormal condition exists, the breaker closest to the abnormality in the distribution path trips before the larger upstream circuit breaker. This isolates and limits service interruption only to the branch experiencing the problem. The coordination of protective devices, especially in a continuous availability server environment, should be designed by an appropriately experienced engineering service.



**CAUTION** \_\_\_\_\_

High current leakage conditions exist when using a PDU because multiple loads are connected to a common source. Use only the locking line cords supplied with the PDU.



**MISE EN GARDE** \_\_\_\_\_

Il existe un risque élevé de fuite de courant lorsqu'une PDU est utilisée, car plusieurs charges sont reliées à une source commune. Utilisez uniquement les cordons d'alimentation dotés d'un système de verrouillage fournis avec la PDU.



**CAUTION** \_\_\_\_\_

Do not connect the power supply until the PDU has a proper earth reference ground.



**MISE EN GARDE** \_\_\_\_\_

Ne branchez pas l'alimentation électrique tant que la PDU a été correctement mise à la terre.

---

## Appendix C

# Standards Compliance

For compliance information, see the following:

- [“Electronic Interference, Immunity, Safety, and Noise Level Standards Compliance” on page C-1](#)
- [“Toxic and Hazardous Substances and Elements Disclosure” on page C-4](#)

## Electronic Interference, Immunity, Safety, and Noise Level Standards Compliance

[Table C-1](#) lists the general electromagnetic interference (EMI), immunity, safety, and noise regulations. All necessary agency labels are on the system.

### NOTES

---

1. This system must be configured with the components listed and described in the product configuration specifications. Deviations from this list of components will void agency certification.
2. You must install all wiring, including power and communications cables, in compliance with local and national electrical code (in the United States, national electrical code NFPA 70). In addition, you must use shielded communications cables to remain in compliance with Federal Communications Commission (FCC) and other international Electromagnetic compatibility (EMC) regulations.
3. All EMC emissions compliance tests are performed at a third-party certified test laboratory.
4. The ftServer models described in this manual may not conform to the compliance standards for all of the countries listed in [Table C-1](#). For specific compliance information, contact your product manager.

This equipment has been tested and found to comply with the limits for a Class A digital device, pursuant to part 15 of the FCC Rules. These limits are designed to provide

reasonable protection against harmful interference when the equipment is operated in a commercial environment. This equipment generates, uses, and can radiate radio frequency energy and, if not installed and used in accordance with the instruction manual, may cause harmful interference to radio communications. Operation of this equipment in a residential area is likely to cause harmful interference, in which case the user will be required to correct the interference at his own expense.



**WARNING** \_\_\_\_\_

**Changes or modification to the product could void the user's authority to operate the equipment.**



**AVERTISSEMENT** \_\_\_\_\_

**Les changements ou les modifications apportés au produit pourraient annuler l'autorité de l'utilisation à se servir de l'équipement.**

**Table C-1. Compliance Standards for ftServer Systems**

| Standard                             | Title   | Country                              |
|--------------------------------------|---|--------------------------------------|
| EN 55022, Class A                    | Limits and methods of measurement of radio interference characteristics of Information Technology Equipment   | European Union                       |
| EN 55024, Class A                    | Information Technology Equipment - Immunity characteristics - Limits and methods of measurement   | European Union                       |
| EN 61000-3-2, Class A                | Electromagnetic compatibility (EMC) – Part 3-2: Limits – Limits for harmonic current emissions (equipment input current <= 16 A per phase)  | European Union                       |
| EN 61000-3-3, Class A                | Electromagnetic compatibility (EMC) – Part 3-3: Limits – Limits of voltage changes, voltage fluctuations and flicker in public low-voltage supply systems (equipment input current <= 16 A per phase) | European Union                       |
| EN 60950-1                           | Safety of Information Technology Equipment  | European Union                       |
| CB SCHEME IEC 60950-1                | Safety of Information Technology Equipment  | International                        |
| UL 60950-1, CSA C22.2 No. 60950-1-03 | Safety of Information Technology Equipment  | Certified to US and Canada standards |

**Table C-1. Compliance Standards for ftServer Systems (Continued)**

| Standard                    | Title  | Country                   |
|-----------------------------|--|---------------------------|
| CISP22, Class A             | Information Technology Equipment: Radio disturbance characteristics                                      | International             |
| FCC CFR47, Part 15, Class A | Code of Federal Regulations, Radio Frequency Devices   | North America             |
| AS/NZS CISPR 22, Class A    | Information Technology Equipment - Radio Disturbance Characteristics - Limits and Methods of Measurement | Australia and New Zealand |
| ICES-003, Class A           | Electronic Emissions from Data Processing Equipment and Electronic Office Machines                       | Canada                    |
| NOM-0190SCFI-1998           | Data processing equipment safety   | Mexico                    |
| EAC                         | Safety of Information Technology Equipment, Electronic Emissions and Immunity                            | Customs Union             |
| CISPR 22, Class A           | Certificate of Compliance with the Radio Regulations   | South Africa              |
| KC, Class A                 | Technical Requirements for EMI Safety for ITE  | South Korea               |
| CCC, Class A                | CCC Qualification (EMC/Safety)   | China                     |
| VCCI, Class A               | Voluntary Control Council for Interference by Information Technology Equipment                           | Japan                     |
| BSMI, Class A               | Information technology equipment - Radio disturbance characteristics                                     | Taiwan                    |

**VCCI Note**

この装置は、クラス A 情報技術装置です。この装置を家庭環境で使用すると電波妨害を引き起こすことがあります。この場合には使用者が適切な対策を講ずるよう要求されることがあります。

V C C I - A

### BSMI Note

警告使用者  
這是甲類的資訊產品、在居住的環境中使用時、可能會造成射頻干擾、在這種情況下、使用者會被要求採取某些適當適對策

### Energy Star Note

As defined by the EPA ENERGYSTAR Program Requirements for Computer Servers, Tier 1 requirements, this server is defined as a “Fully Fault Tolerant Server.” Presently there are no defined requirements, and this category of servers is ineligible to receive an Energy Star rating. As such there are no sales restrictions for local or federal agencies.

## Toxic and Hazardous Substances and Elements Disclosure

ftServer 27x0, 47x0, and 64x0 systems are compliant with the European Union’s Restriction of Hazardous Substances Directive (RoHS).



### WARNING

The lithium battery contains perchlorate material. Special handling may apply. See [www.dtsc.ca.gov/hazardouswaste/perchlorate](http://www.dtsc.ca.gov/hazardouswaste/perchlorate).



### AVERTISSEMENT

La batterie au lithium contient des matières au perchlorate. Une manipulation spécifique peut s’appliquer. Voir le site [www.dtsc.ca.gov/hazardouswaste/perchlorate](http://www.dtsc.ca.gov/hazardouswaste/perchlorate).

---

# Index

## A

AC power service requirements, 2-2  
APC UPS, 2-11  
    PowerChute Network Shutdown, 2-9  
AS/NZS 3112-1993 connector, B-10  
A-side power source, 2-1  
ASN, site planning, 3-3, 4-8

## B

BMC, A-7  
BS connector, 1363/A, B-10  
B-side power source, 2-1

## C

cabinets  
    configuration planning, 5-1, 5-5  
    requirements, 6-1  
    specifications, A-3  
cables  
    Ethernet, 4-5  
    Ethernet network, 4-6  
    Fibre Channel, 4-2, 4-3  
    for iSCSI connections, 4-5  
    planning for, 3-3, 4-1  
    telephone, 3-3  
CAC, getting assistance, 1-2  
CEE connector  
    (7) VII, B-9  
checklist for site planning, 1-2  
circuit, electrical  
    planning information, B-1  
    wiring diagrams, B-2  
communications cables planning, 4-1  
compliance, standards, C-1  
connectors, electrical, B-9  
    BS 1363/A, B-10  
    CEE (7) VII, B-9  
    GB1002-1996, B-10  
    IEC 60309, B-9

NEMA 5-15, B-9  
NEMA L6-20, B-9  
SAA/3/15 AS/NZS 3112-1993, B-10  
SABS 164-1:1992, B-9  
SEV 1011-S24507, B-10

CPP, UPS, 2-11  
current requirements, from PDU, 5-2  
Customer Assistance Center. *See* CAC

## D

dust contamination, 3-2

## E

earth reference ground, B-1  
electrical  
    connectors, B-9  
    grounding, B-1  
    power planning, 2-1  
    wiring, B-1  
embedded Ethernet ports, 1-4, 4-5, A-6  
EMC storage systems, 1-5, 4-2  
environmental requirements  
    maximum rate of temperature change, A-5  
    operating humidity, A-5  
    storage humidity, A-5  
Ethernet cables, 4-5

## F

Fibre Channel  
    cables, 4-3  
    connections, 4-2  
    switches, 1-5  
    switches electrical requirements, 2-3  
ftScalable Storage systems, 1-5  
    Ethernet cables, 4-7  
    Ethernet connections, 4-6  
    Fibre Channel connections, 4-2  
    management PC, 4-6

- G**
  - GB connector, GB1002-1996, B-10
  - grounding the system, 2-14, 6-2, B-1
- H**
  - hubs, network, 3-3
- I**
  - IEC connector, 60309, B-9
- J**
  - jacks, Ethernet, 3-3
- L**
  - LCD monitor units, power cords, 2-11
- M**
  - management PC
    - for ftScalable Storage systems, 4-6, 4-7
  - memory, A-6
  - monitors
    - power cords, 2-11
    - requirements, 6-5
- N**
  - NEMA connector
    - 5-15, B-9
    - L6-20, B-9
  - network (Ethernet) cables, 4-6
  - network management card, UPS, 2-9
- O**
  - optical Fibre Channel connections, 4-2
- P**
  - PCIe adapters
    - U105, 4-6
    - U584, 4-7
  - PCIe slots, A-6
  - PDUs
    - configuration planning, 5-1
    - power (jumper) cables, 2-13
    - power cords, 2-13
    - safety considerations, B-10
    - site planning, A-9
    - specifications, A-9
    - usage calculation
      - sample, 5-4
      - worksheets, 5-4
  - power (AC)
    - cords
      - LCD monitor units, 2-11
      - monitors, 2-11
      - storage enclosures, 2-11
      - systems, 2-11
      - tape-drive enclosures, 2-11
    - electrical requirements, 2-2
    - service requirements, 2-2, 2-4, 2-5
      - A-side, 2-4, 2-5
      - B-side, 2-4, 2-5
    - sources, 2-1
      - direct, 2-6
      - UPS, 2-10
    - system connections, illustrated, 2-6, 2-7
    - UPS connections, illustrated, 2-10
    - wall outlets, 2-4, 3-3
  - PowerChute Network Shutdown, 2-9
  - processors, A-6
  - protective earth ground, B-1
- R**
  - racks
    - configuration planning, 5-1, 5-5
    - requirements, 6-1
  - removing power, 1-10
  - room requirements, 3-1
- S**
  - SAA/3/15 AS/NZS connector, 3112-1993, B-10
  - SABS connector, 164-1:1992, B-9
  - safety notices, 1-10
  - service requirements, AC-power, 2-2
  - SEV connector, 1011-S24507, B-10
  - single-phase circuit connections
    - 120 V AC, B-4
    - 240 V AC, B-5
  - site planning
    - checklist, 1-2
    - overview, 1-1



- space planning, 3-1
  - cables, 3-3
  - future expansion, 3-3
  - room requirements, 3-1
- specifications
  - AC power, 2-2
  - cabinet, A-3
  - PDU, A-9
  - rack-mountable system, A-1
- split-phase circuit connections
  - 120–240 V AC, B-6
- standards compliance, C-1
- star ground, B-2
- Stratus Customer Assistance Center. *See* CAC
- switches
  - circuit breaker, PDU, A-9
  - Ethernet cable planning, 3-3, 4-6
  - Fibre Channel, 1-5
  - site network, 3-3
- system power cords, 2-11
- system specifications, A-1

## T

- tape-drive enclosures, power cords, 2-11
- technical support. *See* CAC
- telephone lines, 4-8
  - for ASN modem assembly, 1-3, 4-8
  - for support calls, 4-8
- telephones for support calls, 1-3
- three-phase circuit connections
  - 208 V AC, B-7
  - 380 V AC, B-8
- transient voltages, B-11

## U

- U105 PCIe Ethernet adapters, 4-6
- U584 PCIe Ethernet adapters, 4-7
- uninterruptible power supply (UPS). *See* UPS
- UPS, 2-11
  - network communication hardware, 2-9
  - network communication software, 2-9
  - network management card, 2-9
  - rack system connections, 2-10

## V

- VTMs, A-7
  - cables, 4-6

## W

- wiring, electrical, B-1

