

Stratus[®] ftServer[®] T40 CO Systems: Site Planning Guide

Stratus Technologies
R591-01

Notice

The information contained in this document is subject to change without notice.

UNLESS EXPRESSLY SET FORTH IN A WRITTEN AGREEMENT SIGNED BY AN AUTHORIZED REPRESENTATIVE OF STRATUS TECHNOLOGIES, STRATUS MAKES NO WARRANTY OR REPRESENTATION OF ANY KIND WITH RESPECT TO THE INFORMATION CONTAINED HEREIN, INCLUDING WARRANTY OF MERCHANTABILITY AND FITNESS FOR A PURPOSE. Stratus Technologies assumes no responsibility or obligation of any kind for any errors contained herein or in connection with the furnishing, performance, or use of this document.

Software described in Stratus documents (a) is the property of Stratus Technologies Bermuda, Ltd. or the third party, (b) is furnished only under license, and (c) may be copied or used only as expressly permitted under the terms of the license.

Stratus documentation describes all supported features of the user interfaces and the application programming interfaces (API) developed by Stratus. Any undocumented features of these interfaces are intended solely for use by Stratus personnel and are subject to change without warning.

This document is protected by copyright. All rights are reserved. No part of this document may be copied, reproduced, or translated, either mechanically or electronically, without the prior written consent of Stratus Technologies.

Stratus, the Stratus logo, ftServer, the ftServer logo, and SINAP are registered trademarks of Stratus Technologies Bermuda, Ltd.

The Stratus Technologies logo, the Stratus 24 x 7 logo, Stratus Inter-network Services Signaling Gateway, Converged Personalized Services, Mobile Call Convergence, and Converged Wide Area Synchronization are trademarks of Stratus Technologies Bermuda, Ltd.

The registered trademark Linux is used pursuant to a sublicense from the Linux Mark Institute, the exclusive licensee of Linus Torvalds, owner of the mark on a world-wide basis. FLEXIm is a registered trademark of Macrovision Corporation.

All other trademarks are the property of their respective owners.

Manual Name: *Stratus ftServer T40 CO Systems: Site Planning Guide*

Part Number: R591

Revision Number: 01

Software Release Number: ftServer System Software for the Linux Operating System, Release 4.0.1

Publication Date: September 2006

Stratus Technologies, Inc.

111 Powdermill Road

Maynard, Massachusetts 01754-3409

© 2006 Stratus Technologies Bermuda, Ltd. All rights reserved.

Contents

Preface	vii
----------------	-----

1. Welcome to Site Planning for ftServer T40 CO Systems	1-1
Site Planning Overview	1-1
Site Planning for Fault-Tolerant Systems	1-2
Site Planning Checklist	1-3
System Documentation	1-6

2. Cabinet and Monitor Requirements	2-1
Cabinet Requirements	2-1
Monitor Requirements	2-4

3. Space Planning	3-1
Room Requirements	3-1
Planning for Cables	3-2

4. Electrical Power Planning	4-1
Redundant Power Sources	4-1
Grounding Requirements	4-1
DC Power Connection Information	4-2
DC Operation Power Service Requirements	4-5
DC Power and Ground Cables	4-6
AC Power Service Requirements	4-6
AC Power Outlet Requirements	4-8
AC Power Cords Supplied by Stratus	4-8
Power Cords for Optional Components	4-9

5. Network and Telephone Line Planning	5-1
Network Cable Requirements	5-1
Telephone Line Requirements	5-3

6. Rack Configuration Planning	6-1
---------------------------------------	-----

Appendix A. System Specifications	A-1
System Specifications	A-1
DC-to-AC Inverter Specifications	A-5

Appendix B. Electrical Circuit and Wiring Information	B-1
Fault Protection Requirements	B-1
Grounding Considerations	B-1
Circuit Wiring Diagrams	B-2
DC Circuit Wiring	B-3
DC Power Cables and Connectors	B-4
AC Circuit Wiring	B-4
Electrical Power Connectors	B-12

Appendix C. Standards Compliance	C-1
---	-----

Index	Index-1
--------------	---------

Figures

Figure 2-1.	Rail Clearance	2-3
Figure 4-1.	Inverter DC Input Cabling Diagram	4-3
Figure 4-2.	AC Output Cabling Diagram	4-5
Figure A-1.	ftServer T40 CO System - Front View	A-2
Figure A-2.	ftServer T40 CO System - Rear View	A-3
Figure B-1.	Star Ground Example	B-2
Figure B-2.	DC System Wiring	B-3
Figure B-3.	Power Input Labeling	B-5
Figure B-4.	Single-Phase 120-Volts AC Circuit Connection	B-6
Figure B-5.	Single-Phase 240-Volts AC Circuit Connection	B-7
Figure B-6.	Split-Phase 120/240 Volts AC Circuit Connection	B-8
Figure B-7.	Three-Phase 208-Volts AC, Y-, or D-Source Circuit Connection, Phase-to-Neutral	B-9
Figure B-8.	Three-Phase 208-Volts AC, Y-, or D-Source Circuit Connection, Phase-to-Phase	B-10
Figure B-9.	Three-Phase 380V AC, Y-, or D-Source Circuit Connection, Phase-to-Neutral	B-11

Tables

Table 1-1.	Ethernet PCI Adapters	1-4
Table 1-2.	ftServer T40 CO Documentation	1-6
Table 4-1.	DC Power and Ground Cables	4-6
Table 4-2.	External AC Power Requirements	4-7
Table 4-3.	Worksheet: A-Side External Power Outlet Requirements	4-8
Table 4-4.	Worksheet: B-Side External Power Outlet Requirements	4-8
Table 4-5.	AC Power Cords for Optional Components	4-9
Table 5-1.	Customer-Supplied Ethernet Cables	5-2
Table 6-1.	Rack Space Usage Calculation	6-1
Table A-1.	System Specifications	A-3
Table A-2.	AA-P86600 DC-to-AC Inverter Specifications	A-5
Table B-1.	Connectors for AC Power Outlets	B-12
Table C-1.	EMI Standards	C-2
Table C-2.	Immunity Standards	C-2
Table C-3.	Safety Standards	C-2
Table C-4.	Noise Standards	C-2
Table C-5.	NEBS (Telecommunications) Standards	C-3

Preface

The *Stratus ftServer T40 CO Systems: Site Planning Guide* (R591) documents the site requirements and customer responsibilities related to preparing a site for the installation of ftServer T40 CO systems.

This manual is intended for those responsible for preparing a site for the installation of an ftServer T40 CO system.

Revision Information

This manual is a revision.

This revision incorporates the following changes:

- information on requirements for [system location](#) and [power sources](#)
- information on a new [Japanese power cord](#)

Notation Conventions

This document uses the notation conventions described in this section.

Warnings, Cautions, and Notes

Warnings, cautions, and notes provide special information and have the following meanings:



WARNING _____

A warning indicates a situation where failure to take or avoid a specified action could cause bodily harm or loss of life.



CAUTION _____

A caution indicates a situation where failure to take or avoid a specified action could damage a hardware device, program, system, or data.

NOTE

A note provides important information about the operation of an ftServer system.

Typographical Conventions

The following typographical conventions are used in this document:

- The bold font emphasizes words in text. For example:
Before handling or replacing system components, make sure that you are properly grounded by using a grounded wrist strap.
- The italic font introduces new terms. For example:
Many hardware components are *customer-replaceable units* (CRUs), which can be replaced on-site by system administrators with minimal training or tools.

Getting Help

If you have a technical question about ftServer system hardware or software, try these online resources first:

- **Online documentation at the StrataDOC Web site.** Stratus provides complimentary access to StrataDOC, an online-documentation service that enables you to view, search, download, and print customer documentation. You can access StrataDOC at the following Web site:

<http://stratadoc.stratus.com>

A copy of the StrataDOC CD-ROM for your system is included with this release. To order additional copies of the StrataDOC CD-ROM or to obtain copies of printed manuals, do one of the following:

- If you are in North America, call the Stratus Customer Assistance Center (CAC) at (800) 221-6588 or (800) 828-8513, 24 hours a day, 7 days a week.
- If you are outside North America, contact your nearest Stratus sales office, CAC office, or distributor; see <http://www.stratus.com/support/cac/index.htm> for CAC phone numbers outside the U.S.
- **Online support from Stratus Customer Service.** You can find the latest technical information about an ftServer system through online product support at the [Stratus Technical Support Web site](http://www.stratus.com/support/technics.htm):

<http://www.stratus.com/support/technics.htm>

If you are unable to resolve your questions with the help available at these online sites, and the ftServer system is covered by a service agreement, please contact the [Stratus](http://www.stratus.com)

[Customer Assistance Center \(CAC\)](#) or your authorized Stratus service representative. For information about how to contact the CAC, see the following Web site:

<http://www.stratus.com/support/cac/>

Commenting on the Documentation

To provide corrections and suggestions on the documentation, send your comments in one of the following ways:

- By clicking the **site feedback** link at the bottom of a Help topic. Information to identify the topic is supplied in the StrataDOC Web Site Feedback form.
- By email to Comments@stratus.com. If it is possible, please include specific information about the documentation on which you are commenting:
 - For a printed document or a document in PDF format, include the title and part number from the Notice page and the page numbers.
 - For online documentation, include the Help subject and topic title.

This information will assist Stratus Information Development in making any needed changes to the ftServer system documentation. Your assistance is most appreciated.

Regulatory Notice

All regulatory notices are provided in [Appendix C, “Standards Compliance.”](#)

Chapter 1

Welcome to Site Planning for ftServer T40 CO Systems

For an overview of the information you need to know and of the tasks you need to perform to prepare a site for ftServer T40 CO systems, see:

- [“Site Planning Overview”](#) on page 1-1
- [“Site Planning for Fault-Tolerant Systems”](#) on page 1-2
- [“Site Planning Checklist”](#) on page 1-3
- [“System Documentation”](#) on page 1-6

Site Planning Overview

[Site planning for fault-tolerant systems](#) includes:

- [Space planning](#)

Provide adequate space for the system or cabinet and for a desk or table to accommodate components outside a cabinet. Also provide enough space for servicing the systems and components.

Provide an environment that meets the system's requirements for ambient temperature and air quality.

- [Purchasing an appropriate cabinet and monitor](#)

If you do not purchase a monitor from Stratus, provide a monitor that meets the system's requirements.

Provide a cabinet that meets the system's requirements.

- [Electrical \(DC\) power planning](#)

Provide a nominal input voltage of 48 VDC. The input voltage should be at least 42.75 VDC and no more than 56.7 VDC.

- [Electrical \(AC\) power planning](#)

Provide electrical AC power sources that meet the requirements of optional components.

- [Network and telephone line planning](#)

Provide sufficient network and analog telephone lines.

- [Rack space planning](#)

Ensure that you have sufficient space available in an appropriate cabinet.

Use the “[Site Planning Checklist](#)” on page 1-3 to track your site preparation progress.

For a list of other documents related to your ftServer system, see “[System Documentation](#)” on page 1-6.

During the site planning and preparation processes, work closely with your facilities group or contractor to determine space, power, and environmental requirements. Enlist their help to provide a suitable location with sufficient alternating current (AC) power, heating, ventilation and air conditioning (HVAC) capabilities, and network and telephone connections.

If your system is covered by a service agreement and you need help with site planning, contact the Stratus Customer Assistance Center (CAC) or your authorized Stratus service representative. If you have a contract with the CAC or your authorized Stratus service representative to install the system, contact them after you have prepared the installation site and moved the system to the site. For more information about the CAC, see in the Preface or the [CAC Web site](#) at:

<http://www.stratus.com/support/cac/>

See [Appendix A, “System Specifications”](#) for the specifications of your ftServer system and the *Stratus ftServer Systems: Peripherals Site Planning Guide (R582)* for specifications of other components.

Site Planning for Fault-Tolerant Systems

Consider the following specific fault-tolerant features of ftServer systems for site planning:

- *Lockstep technology* means that the systems contain redundant hardware. The systems contain two enclosures, each containing a full computing environment that consists of a CPU element and an I/O element.

If a component in a CPU element malfunctions, the corresponding CPU element in the other enclosure, which is processing the same information in *lockstep*, continues processing without interruption. If a component in the I/O element malfunctions, the system fails operation over to the corresponding element in the other enclosure and continues to operate normally. The only consequences are that the system is less fault tolerant, and any I/O throughput distributed between

the enclosures may be reduced. To restore full fault tolerance, an enclosure can be replaced without taking the system offline.

- ftServer systems can connect to the Stratus ActiveService Network (ASN).

Connecting a system to the ASN allows the CAC or your authorized Stratus service representative to remotely diagnose, troubleshoot, and resolve problems online.

To enable connectivity to the ASN, a modem can be attached directly to the system and managed by system software.

Site Planning Checklist

Referring to the information in this document, answer the following questions:

Planning for ASN Connectivity

- Will your system use an ASN modem or the Internet to connect to the ASN?
- If your system will use the Internet, do you have an Internet connection available for the system?
- If your system will use an ASN modem, do you have an external analog telephone line available for the ASN modem?

NOTE

A dedicated phone line provides the most reliable service. ASN calls routed through a PBX may be slow due to load on the PBX, or may not complete successfully due to disconnections. If you must use a PBX, do not route the telephone extension through a switchboard; instead, provide a direct-dial analog number.

- Do you have an additional telephone line and telephone near the operator's station for voice communications when calling for support?

Planning for SINAP/SS7

- If you are connecting a U928 Four-Port T1/E1 PCI Adapter to a T1, E1, or J1 line, do you have a channel service unit/data service unit (CSU/DSU)? For more information about planning for a U928 PCI adapter, see the *Stratus ftServer Systems: PCI Adapter Guide* (R461).

Planning for Optional Components

- The system contains four 10/100/1000 megabits-per-second (Mbps) Ethernet ports. Will your system additionally include any of the following PCI adapters for network communications? If so, indicate the total number of ports, and plan network connections for all Ethernet ports you will use.

Table 1-1. Ethernet PCI Adapters

Adapter	Number of Ports
U574 Dual-Port Fiber Gigabit Ethernet Adapter	
U575 Dual-Port Copper Gigabit Ethernet Adapter	

- Will your system connect to any storage enclosures? If so, the system requires a pair of PCI adapters, which are provided when you order the storage enclosure. If you order the enclosure at the same time you order the system, the required PCI adapters are installed at the factory. See the *Stratus ftServer Systems: Peripherals Site Planning Guide* (R582) for a list of the supported storage enclosures, descriptions of the storage enclosures, and the names of the required PCI adapters.
- Will you supply your own monitor or will Stratus supply the monitor? Is the monitor rack-mountable or do you need to provide a table or desk?

NOTE _____

Use the USB keyboard and mouse supplied by Stratus.

- Will your system include any tape drives? The tape drives supplied with your system are rack-mountable. If you order the tape drive at the same time you order the system, the required PCI adapters are installed in the system. See the *Stratus ftServer Systems: Peripherals Site Planning Guide* (R582) for a list of the supported tape-drive enclosures, descriptions of the tape-drive enclosures, and the names of the required PCI adapters.

Planning AC Power

- Do you have nominal input voltage of 48 VDC available for the DC-to-AC inverters?
- What are the lengths and types of the ground cables provided with your system?
- What optional, AC-powered components will you use?
- What are the AC power requirements of all optional components?
- What are the lengths and types of the power cords that are provided for the optional components?
- What type of AC receptacles do you need to provide?
- Is the AC power service wired properly?

Planning Space for Your System

- Will your system and its external components fit where you plan to place them?
- What is the height of the cabinet you will use and what is the total height of the systems and components that will be installed in the cabinet? Will the items fit into the cabinet? What components will be located outside the cabinet?
- What are the lengths and types of the interface and communications cables that will connect to your system?
- Have you created a sketch of how you plan to arrange the system at the installation site? Consider the available cable lengths, the placement of external devices, and the location of network and voice communication connections.

On the sketch, show the following:

- Location of the system and its external components
- Power cords, and telephone and interface cables
- Locations of AC power receptacles, phone jacks, Ethernet jacks, switches, and/or hubs

NOTE

Make sure that all cords and cables are long enough to reach between their respective components and connectors. Route all cables out of the way of foot traffic.

Working with Other Groups

- Have you provided your facilities group and contractors with the sketch and copies of the following?
 - [“DC Power Connection Information” on page 4-2](#) and [“AC Power Service Requirements” on page 4-6](#)
 - [Tables 4-2](#), a worksheet for determining AC power requirements for optional components that do not draw power from the DC-AC inverter
 - [Appendix B, “Electrical Circuit and Wiring Information”](#)
 - Any notes you have about site planning
- Have you reviewed and discussed the requirements with the facilities personnel and contractors to ensure that all site modifications are understood and implemented?

If you have any questions about the number and types of components, contact your Stratus account executive or distributor.

System Documentation

When you receive your system, you receive a printed copy of the installation guide and warranty for your system and the full system documentation set on CD-ROM.

You can order additional copies of the ftServer T Series StrataDOC CD-ROM (part number R003LCDK).

To order documentation, customers in North America can call the CAC at (800) 221-6588 or (800) 828-8513, 24 hours a day, 7 days a week. Customers outside North America can contact the nearest Stratus Sales office, CAC office, or distributor.

Stratus provides complimentary access to StrataDOC at the following Web site:

<http://stratadoc.stratus.com>

Table 1-2 lists ftServer T40 CO system documents and the tasks described in each document.

Table 1-2. ftServer T40 CO Documentation

Document	Task
<i>Stratus ftServer T40 CO Systems: Site Planning Guide</i> (R591)	Prepare a site for installation of your ftServer system
<i>Stratus ftServer Systems: Peripherals Site Planning Guide</i> (R582)	Find information about optional equipment that you have ordered with your system that is needed to complete site preparation
<i>Stratus ftServer T40 CO Systems: Installation Guide</i> (R588)	Install your system, including mounting the system in a cabinet Find the part number of a customer-replaceable unit (CRU) Start the system for the first time
<i>Stratus ftServer T40 CO Systems: Operation and Maintenance Guide</i> (R589)	Start up, shut down, and operate your system Troubleshoot system hardware Remove and replace CRUs
<i>Read Me First: Unpacking ftServer T40 and T65 Systems</i> (R590)	Inspect and unpack ftServer system hardware that you install in your cabinet
<i>Stratus ftServer Systems: PCI Adapter Guide</i> (R461)	Install, configure, replace, or troubleshoot PCI adapters

Table 1-2. ftServer T40 CO Documentation *(Continued)*

Document	Task
<i>Stratus ftServer Systems: Technical Reference Guide (R550)</i>	Consult technical reference information for ftServer systems Change BIOS settings
<i>Release Notes: Stratus ftServer System Software for the Linux Operating System (R005L)</i>	Learn the contents of the latest ftServer System Software release Learn the latest information about the product Learn about significant known problems and how to work around or avoid the problems
<i>Stratus ftServer System Administrator's Guide for the Linux Operating System (R003L)</i>	Use tools that are provided by the operating system software, ftServer System Software, and other vendors to manage the system Use ftServer management software to administer or troubleshoot ftServer systems Install and upgrade the Linux operating system and ftServer System Software, and BIOS and BMC firmware Manage data storage devices Install and configure simple network management
<i>Stratus ActiveService Network Configuration Guide (R072)</i>	Configure your system for support by the Stratus ASN

Chapter 2

Cabinet and Monitor Requirements

For requirements related to providing your own cabinet and monitor, see:

- [“Cabinet Requirements” on page 2-1](#)
- [“Monitor Requirements” on page 2-4](#)

Cabinet Requirements

Make sure the cabinet contains a rack that is 19-in. wide and that meets the Electronic Industries Association (EIA) 310-D standard.

In general, consider the following factors during your site planning for systems in cabinets:

- **Elevated Operating Ambient Temperature**—If installed in a closed or multi-unit rack assembly, the operating ambient temperature of the rack environment may be greater than room ambient. Therefore, consideration should be given to installing the equipment in an environment compatible with the maximum ambient temperature (T_{ma}) specified by the manufacturer.
- **Reduced Air Flow**—Installation of the equipment in a rack should be such that the amount of air flow required for safe operation of the equipment is not compromised.
- **Mechanical Loading**—Mounting of the equipment in the rack should be such that a hazardous condition is not achieved due to uneven mechanical loading.
- **Circuit Overloading**—Consideration should be given to the connection of the equipment to the supply circuit and the effect that overloading of the circuits might have on overcurrent protection and supply wiring. Appropriate consideration of equipment nameplate ratings should be used when addressing this concern.

Make sure that the cabinet meets the following requirements:

- The cabinet can support the weight of all the components you plan to install in it. Refer to [Appendix A, “System Specifications”](#) and the *Stratus fitServer Systems: Peripherals Site Planning Guide* (R582), for the weights of components supplied by Stratus.

- The cabinet contains two front and two rear vertical EIA rails, one in each corner of the cabinet, that have the EIA **universal** square-hole pattern as defined in the EIA 310-D specification.
- The front vertical rails extend at least 0.5 in. (1.27 cm) beyond the inside edge of the accessory leg, if present, to allow the mounting rails to be fitted. See [Figure 2-1](#).
- The distance between the front vertical rails and the inside of the front door is at least 3.0 in. (7.62 cm).
- The distance between the rear of the system chassis and the inside of the rear door is at least 6.0 in. (15.24 cm).
- The distance between the front and rear vertical rails is between 24.5 in. and 30 in. (62.23 cm and 76.20 cm).
- The vertical mounting rails accept 10-32 cage nuts and mounting hardware.
- The vertical mounting rails are plated or some other method is used to ensure continuity for grounding between installed equipment.
- Cable management brackets are provided to support and constrain data and power cords so that the cables do not interfere with air flow out of the rear of the enclosures, and so that the connectors do not disconnect or break.
- The cabinet provides enough stability so that system components pass Telcordia GR-63-CORE Section 4.4 regulations for earthquake vibration (Zone 4), operation vibration, and transport vibration.
- To prevent stray voltages, all components are grounded together through the vertical mounting rails to the cabinet frame, and then to local building ground. To ensure signal quality, use a grounding cable provided by Stratus for local building ground.
- There is a plan for maintaining cables and wires to the cabinet by either running them under the floor or placing them overhead in an overhead cable tray.
- Air flows through the cabinet from front to back.
- Air does not recirculate within the cabinet.
- Filler panels cover any unused rack space to prevent air recirculation.
- Blockers are installed between the vertical mounting rails and the side panels at the rear of the cabinet.
- Vents are evenly distributed on the front and rear doors and comprise at least 63% of the surface area.

NOTE _____

If your cabinet does not have vented front and rear doors, you can remove the doors from the cabinet while your ftServer system is operating.

- The final installation conforms to all emission, immunity, safety, and other applicable regulations.

Figure 2-1 shows the required rail clearance between the front vertical rails and the inside edge of an accessory leg.

Figure 2-1. Rail Clearance

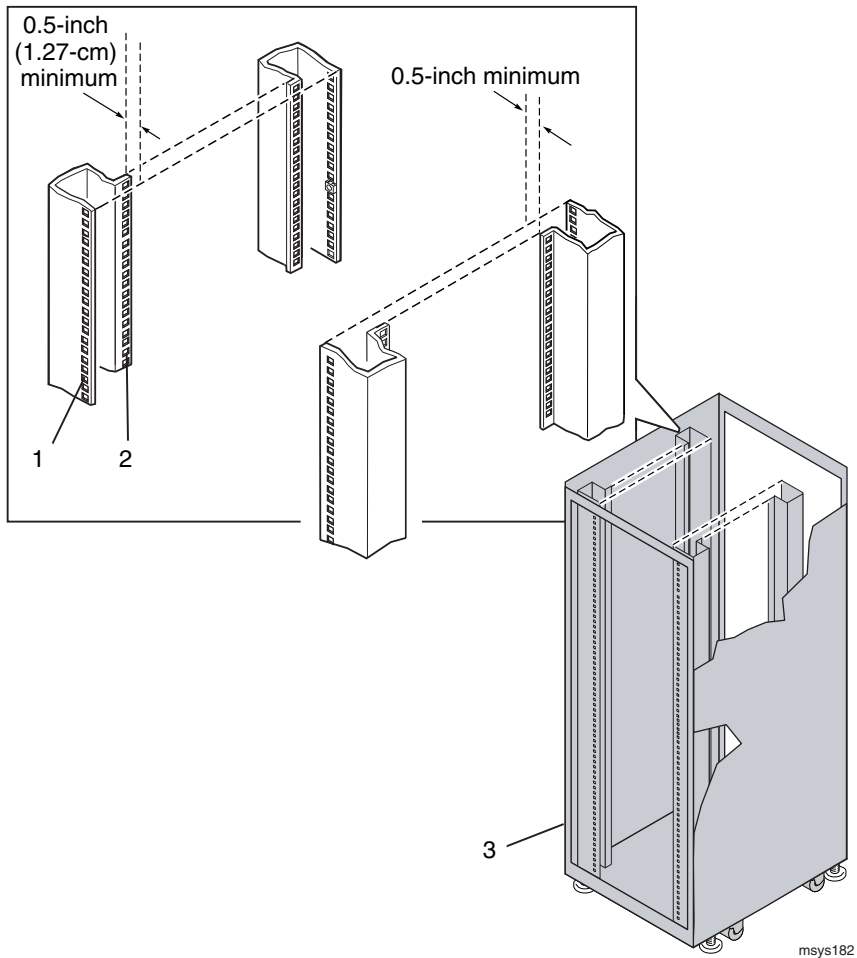

- 1 Front vertical EIA rail
- 2 Accessory leg
- 3 Front of cabinet

Monitor Requirements

If you are using a monitor that is not supplied by Stratus, make sure that:

- The monitor accepts universal 100–240 VAC, 50/60 Hz power.
- The VGA cable has a 15-pin D-sub connector.
- The power cord for the monitor is long enough to reach the power source.
- The plug type on the power cord is compatible with the external power source at the site.

To ensure system fault-tolerance, use the keyboard and mouse provided by Stratus, which has been tested to work correctly with ftServer systems.

Chapter 3

Space Planning

For information about planning sufficient space for your ftServer system, see:

- [“Room Requirements” on page 3-1](#)
- [“Planning for Cables” on page 3-2](#)

Room Requirements

Your ftServer system is intended to be installed in restricted access areas (dedicated equipment rooms, equipment closets, or the like). To ensure that the installation site provides a properly equipped, cooled, and sized environment, make sure that the site:

- Provides clearances for air circulation and servicing the system
Locate the front and rear of the system at least 2.5 ft (0.76m) away from walls and other obstructions.
- Maintains reasonable temperature and humidity levels and has a thermometer and humidistat to monitor room temperature and humidity
- Is as free of dust as possible, meeting, at a minimum, ISO 14644-1 class 8 standards for a clean-room environment

Dust buildup in the system can impede air circulation and heat transfer, causing components to become less reliable as the ambient temperature rises.

Fans clogged by dust fail to expel hot air, causing circuit boards to overheat and fail.

Dust on circuit boards raises the temperature, thus reducing the component's mean time between failure (MTBF)

Dust circulating in the room increases the risk of fire within the room by providing potential combustible material within the environment

Dust contamination on tape devices causes mis-reads and -writes, leading to failure of attempts to back up and restore data.

- Provides a table or desktop for external devices such as a telephone, and an external monitor, keyboard, and mouse

- Provides cutouts in the floor for routing cables, if the site has an elevated floor



CAUTION

Do not place the system in an area of high electrostatic discharge. Static electricity may damage components. Do not locate components near transformers or other electromagnetic devices.

See [Appendix A, “System Specifications”](#) and *Stratus ftServer Systems: Peripherals Site Planning Guide (R582)* for the dimensions of system components.

Planning for Cables

To accommodate cables from your system, make sure to provide:

- Two telephone lines:
 - One telephone line for use when calling for service
 - One telephone line for the ASN modem, if used
- Ethernet jacks, switches, or hubs, as needed
- For the DC converter, a DC power source with a nominal input voltage of 48 VDC. The input voltage should be at least 42.75 VDC and no more than 56.7 VDC
DC power cables generally have a wider diameter than AC cables. Be sure to leave enough space for the wider curves these cables require.
- For optional components, AC wall outlets within reach of the power cords from the components

Make sure that cables you plan to connect to the system are long enough to reach between the system and external components or connections. See the *Stratus ftServer Systems: Peripherals Site Planning Guide (R582)* for information about cable lengths for peripheral components available from Stratus.

Chapter 4

Electrical Power Planning

For information about planning appropriate electrical power for your system and its peripheral components, see:

- [“Redundant Power Sources”](#)
- [“Grounding Requirements”](#)
- [“DC Power Connection Information” on page 4-2](#)
- [“AC Power Service Requirements” on page 4-6](#)

Related Topic

- [Chapter 6, “Rack Configuration Planning”](#)

Redundant Power Sources

You must provide two separate DC power sources to supply power to two DC-to-AC power inverters. Both inverters supply AC power to the ftServer T40 CO systems. One of the sources must also provide AC power to an LCD monitor unit, if purchased. The inverter units contain no user-serviceable parts.

Grounding Requirements



WARNING

Incorrect grounding can cause severe personal injury and extensive equipment damage.

The ftServer system obtains an earth reference ground over independent ground connections to the cabinet frame. Ensure that a high-integrity safety-ground conductor is installed as part of the wiring system (in accordance with Bellcore standards).

See [“Grounding Considerations” on page B-1](#) for a more complete discussion of ftServer system grounding.

DC Power Connection Information

This section includes the following topics:

- [“DC Operation Power Service Requirements” on page 4-5](#)
- [“DC Power and Ground Cables” on page 4-6](#)

Stratus supplies power cables to connect each inverter’s DC input cable to the central office (CO) power supply. [Figure 4-1](#) shows the DC input and ground cables on the rear of the DC inverter assemblies.



WARNING

Wiring must meet ftServer T40 CO system needs and comply with local safety codes and requirements.

Figure 4-1. Inverter DC Input Cabling Diagram

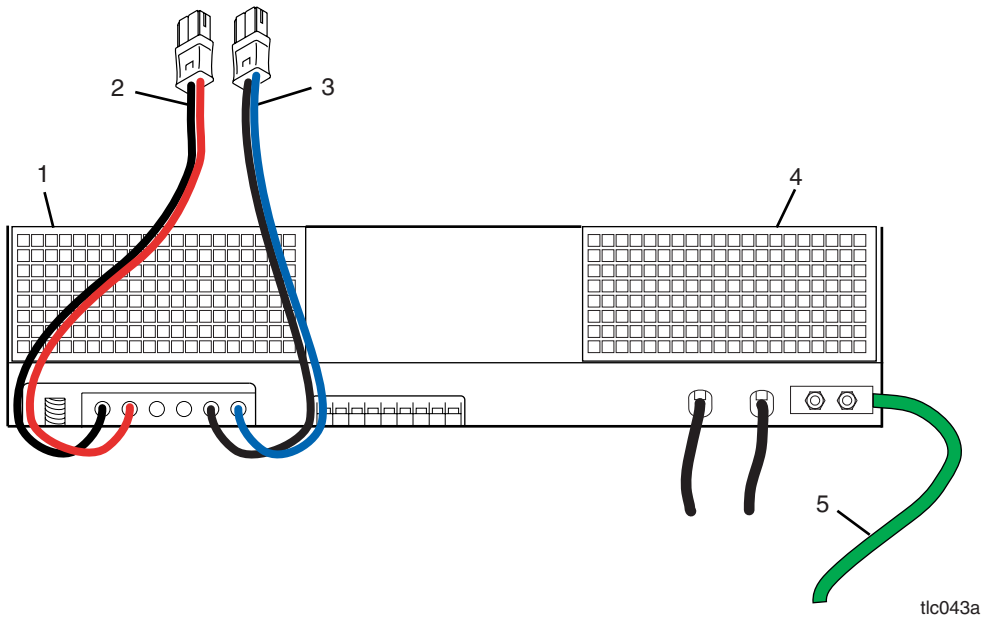

tlc043a

- | | | | |
|---|-----------------------|---|----------------------|
| 1 | B-side DC inverter | 4 | A-side DC inverter |
| 2 | A-side DC input cable | 5 | Chassis ground cable |
| 3 | B-side DC input cable | | |

NOTES

1. User-supplied DC power cables that connect directly from the CO supply to the DC inverter's DC input cable must use an Anderson Power Products[®] connector (Anderson part number SBS50BLU#6-BK) and two contacts (Anderson part number 1339G2-BK) at the inverter end.

User-supplied DC power cables that connect directly from the CO supply to the rear of the DC inverter must use a FCI- Burndy[®] ring lug connector (Burndy part number YAV6CL2TC14FX) at the inverter end.

2. The product is not "Permanently Connected Equipment". Both the A and B side -48 VDC power sources are easily disconnected using approved pin and sleeve connectors.

Each inverter provides AC power to the system components through AC output “Y” cords. One end of each “Y” cord provides AC power to one side of the system. The other end provides AC power to external components. One cord has a T-plug adapter to provide one additional AC outlet.

Figure 4-2 shows how the AC output cables and splitters are connected to an ftServer T40 CO system.

NOTE _____

The AC output cord T-plug adapter can be connected to either the A-side AC output cord or the B-side AC output cord.

The DC power inverters support only the ftServer T40 CO system and LCD monitor unit. Attach only monitors supplied by Stratus to the DC-to-AC inverters.



CAUTION _____

Do not connect tape drives, storage enclosures, monitors you do not purchase from Stratus, or other AC-powered components to the DC power inverters. Doing so may damage the inverters and the attached components.

Connect the tape drive directly to an AC wall outlet. Storage enclosures require two separate power sources. Connect the two power cords from a storage enclosure directly to two electrically separate power sources. See [“AC Power Service Requirements” on page 4-6](#) and [“AC Power Outlet Requirements” on page 4-8](#) for AC-planning information.

Figure 4-2. AC Output Cabling Diagram

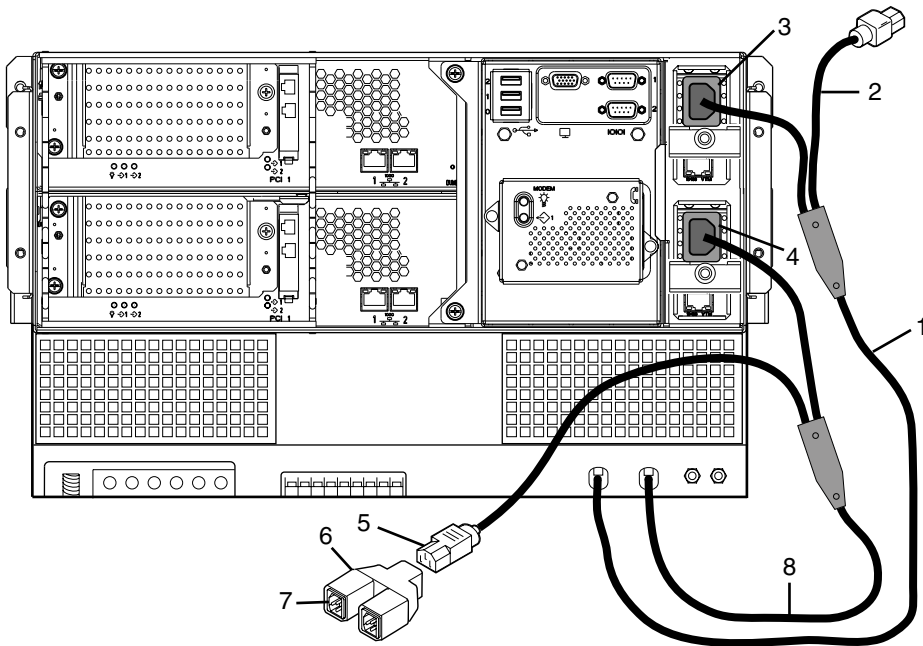

t40001

- 1 B-side AC output Y cord
- 2 Extra AC output connector (not for tape drive)
- 3 System backplane B-side receptacle
- 4 System backplane A-side receptacle
- 5 AC output connector
- 6 AC output cord T-plug adapter
- 7 Monitor receptacle
- 8 A-side AC output Y cord

For related information, see [“DC Operation Power Service Requirements”](#) and [“DC Power and Ground Cables”](#) on page 4-6.

DC Operation Power Service Requirements

Provide a nominal input voltage of 48 VDC for your systems. The input voltage should be at least 42.75 VDC and no more than 56.7 VDC. The DC-to-AC inverters provide AC power to the system and monitor. See [“Grounding Considerations”](#) in [Appendix B](#) for electrical circuit and wiring information.

DC Power and Ground Cables

Stratus supplies tested and approved cables for the ftServer T40 CO system. [Table 4-1](#) lists these cables, their descriptions, and part numbers.



WARNING

User-supplied power or ground cables must meet ftServer T40 CO system needs and comply with local safety codes and requirements.

Table 4-1. DC Power and Ground Cables

Cable	Part Number	Description	Length
Ground cables	B52100-06	Inverter protective ground (Green/6AWG)	6 ft. (1.82m)
DC input cables - A side	B52200-25	Inverter DC input cable (Red/Black/6AWG)	25 ft. (7.62m)
DC input cables - B side	B52500-25	Inverter DC input cable (Blue/Black/6AWG)	25 ft. (7.62m)
DC input cables Pigtail	B52300-20	Inverter DC extension cable (Red/Black/6AWG)	1.67 ft. (0.51m)
AC output Y cord	B001157	Inverter AC output Y cord	N/A
T-Plug adapter	AW-B52600	IEC-C14 to 2 IEC-C13 connectors (for optional and external components)	N/A
AC jumper cord	B50200-01M	Black (2 per T-plug adapter)	3.28 ft. (1m)

AC Power Service Requirements

From the *Stratus ftServer Systems: Peripherals Site Planning Guide* (R582), obtain the nominal input line voltage (volts AC) and frequency (Hz) required for optional, AC-powered components. In general, provide 100–240 VAC at 50 or 60 Hz for optional components.

For detailed information about the plug types and lengths of the power cords provided with the optional components, see [Table 4-5](#).

The power service must be properly wired and grounded according to local standards and regulations. See [Appendix B, “Electrical Circuit and Wiring Information”](#) for more information.

NOTE

Circuit breakers must provide a protective earth ground current at a maximum of 3.5 milliamperes for each AC power cord.

Storage and tape-drive enclosures cannot be connected to any of the AC outputs from the DC-to-AC inverters. For each tape-drive enclosure, provide one external AC power source. For each storage enclosure, provide two electrically separate external AC power sources. From the *Stratus ftServer Systems: Peripherals Site Planning Guide* (R582), obtain the AC power requirements, in watts, for your storage and tape-drive enclosures. Make sure that your site power planning supplies sufficient wattage.

You can use [Table 4-2](#) to summarize the AC power requirements.

To determine AC power requirements

1. In the Quantity column, write the number of each type of component.
2. In the @ Power (Watts) column, write the power, in watts, for each component. For components you purchase from Stratus, you can obtain these values from the *Stratus ftServer Systems: Peripherals Site Planning Guide* (R582).
3. Multiply the entry in the Quantity column by the number in the @ Power (Watts) column, and enter the result in the AC Power (Extended) column.
4. Add the values in the AC Power (Extended) column, and enter the sum on the bottom line. This value indicates the maximum power requirement for each power source.

Table 4-2. External AC Power Requirements

System Component	Quantity		@ Power (Watts)		AC Power (Extended)
Tape-drive enclosure [†]		x		=	
Storage enclosure (if AC-powered) †		x			
User-supplied components		x			
TOTAL A-SIDE EXTERNAL POWER REQUIREMENTS					
Storage enclosure (if AC-powered)†		x			
TOTAL B-SIDE EXTERNAL POWER REQUIREMENTS					

† See the *Stratus ftServer Systems: Peripherals Site Planning Guide* (R582) for the wattage of optional components you purchase from Stratus.

AC Power Outlet Requirements

Use Tables 4-3 and 4-4 to determine the number of AC power outlets required.

1. In the Quantity column, write the number of each type of component.
2. Multiply the value in the Quantity column by the value in the Outlets column, and enter the total in the Subtotal column.
3. Add the values in the Subtotal column and enter the sum next to TOTAL NUMBER OF A-SIDE POWER OUTLETS and TOTAL NUMBER OF B-SIDE POWER OUTLETS.

Table 4-3. Worksheet: A-Side External Power Outlet Requirements

Component	Quantity		Outlets	Subtotal
Storage enclosures		x	1	
LCD monitor units or external monitors		x	1	
Tape drives		x	1	
Other peripheral components		x		
TOTAL NUMBER OF A-SIDE POWER OUTLETS				

Table 4-4. Worksheet: B-Side External Power Outlet Requirements

Component	Quantity		Outlets	Subtotal
Storage enclosures		x	1	
Other peripheral components		x		
TOTAL NUMBER OF B-SIDE POWER OUTLETS				

AC Power Cords Supplied by Stratus

Stratus supplies tested and approved AC power cords for the [optional components](#) you purchase from Stratus.



WARNING _____

Place all power cords out of the way of foot traffic.

Power cords described as Domestic are made with American Wire Gauge (AWG) cordage and are intended for use in North America. Refer to UL 62 and CSA C22.2, No. 49. All other power cords are made with International Harmonized cordage and are intended for use in the specified countries, and other countries that use that standard.

Power Cords for Optional Components

Table 4-5 lists the available power cords to connect optional components directly to external AC power sources.

Table 4-5. AC Power Cords for Optional Components

Locale	Rating	Plug Type	Length	Marketing ID
North America	15A/120VAC	NEMA 5-15	7 ft	B50101-07
North America	15A/120VAC	NEMA 5-15	10 ft	B50102-10
United States (Domestic)	15A/127VAC	NEMA 5-15	10 ft	B50106-10
Australia	10A/250VAC	AS/NZS 3112:1993	2.5m	B50121-25M
China (CCC)	10A/250VAC	GB1002-1996	2.5m	B50162-08
Europe (Continental)	16A/250VAC	CEE 7 VII	2.5m	B50109-25M
India	13A/250VAC	SABS164-1:1992; ZA/3	2.5m	B50149-25M
Israel	16A/250VAC	SI 32:1971	2.5m	B50129-25M
Italy	16A/250VAC	CEI23-16;	2.5m	B50133-25M
Japan	15A/120VAC	NEMA 5-15	15 ft	B50160-15
New Zealand	10A/250VAC	AS/NZS 3112:1993	2.5m	B50121-25M
South Africa	13A/250VAC	SABS164-1:1992; ZA/3	2.5m	B50149-25M
Switzerland	10A/250VAC	SEV 1011-S24507	2.5m	B50137-25M
Taiwan	15A/127VAC	NEMA 5-15	4.4m	B50173-25M
United Kingdom	13A/250VAC	BS1363/A	2.5m	B50113-25M

Chapter 5

Network and Telephone Line Planning

For information about planning network and telephone lines for your system, see:

- “Network Cable Requirements” on page 5-1
- “Telephone Line Requirements” on page 5-3

Network Cable Requirements

U928 Four-Port T1/E1 PCI Adapters and Ethernet PCI adapters are typically supplied in pairs and teamed in software for fault tolerance. Each member of the pair requires cables.



WARNING

Make sure network cables can be routed out of the way of foot traffic.

[Table 5-1](#) describes the cables you must supply for network connectivity. Be sure to provide cables of sufficient length for the distance between the system and a wall jack or hub.

NOTES

1. Software upgrade services are available from [Stratus Professional Services](#). For a list of available services, see <http://www.stratus.com/services/ps/offerings.htm>.
2. If you have a unique network requirement, contact [Stratus Professional Services](#). For a list of available services, see <http://www.stratus.com/services/ps/offerings.htm>.
3. See the *Stratus ftServer Systems: PCI Adapter Guide* (R461) for more information about the adapters Stratus supplies for your ftServer system.

Table 5-1. Customer-Supplied Ethernet Cables

Component	Quantity	Cable
<p>10/100/1000-Mbps system Ethernet port</p> <p>Dual-port 10/100/1000Base-T Ethernet PCI Adapter (gigabit copper adapter for servers)</p>	<p>2 or 4</p> <p>2 for each pair of 10/100/1000Base-T Ethernet ports</p>	<p>24 AWG Unshielded Twisted Pair (UTP) EIA/TIA-Verified, Category-3 or Category-5 wire, with RJ-45 modular connectors terminated with pair-wiring adhering to the EIA/TIA 568-A or EIA/TIA 568-B standard.</p> <p>For connections to an Ethernet hub or switch, provide a straight-through cable.</p> <p>For 100- or 1000-Mbps (fast Ethernet) operation, provide full-duplex, or Category-5 Ethernet cables.</p> <p>The maximum allowable distance from an Ethernet port to a switch or a hub is 328 ft (100m) .</p>
<p>Dual-port 1000Base-SX Ethernet PCI Adapter (gigabit fiber-optic adapter for servers)</p>	<p>2 for each pair of 1000Base-SX Ethernet ports</p>	<p>Multimode, 62.5- or 50-micron, DUAL fiber cable with LC-type connectors to the PCI adapter, and connectors on the other end that are compatible with the network switch. The maximum distance between the U574 PCI adapter and a switch is 902 ft (275m).</p>
<p>U928 Four-Port T1/E1 PCI Adapter</p>	<p>2 for each pair of ports you will use</p>	<p>Standard category 5 cable with T1/E1/J1 pin-outs through RJ-48C connectors to connect to a CSU/DSU</p> <p>The maximum length of the cable is 655 feet (approximately 200 meters) without a repeater.</p> <p>A G.703 75- to120-ohm adapter is required for a connection to an E1 circuit that requires a 75-ohm BNC termination. You can order this G.703 adapter from Stratus; its part number is B333.</p> <p>Loopback plugs for all configured ports not in use.</p> <p>See the <i>Stratus fitServer Systems: PCI Adapter Guide</i> (R461) for more information.</p>

Telephone Line Requirements

Generally, two telephone lines are required to ensure technical support for your ftServer system:

- One telephone line for use when calling for service
- One analog telephone connection point for the ASN modem, if used

A 7-ft (2.13m) telephone cable, part number AW-B20245, is shipped with the modem assembly.

NOTE _____

A dedicated phone line provides the most reliable service. ASN calls routed through a PBX might be slow due to the load on the PBX, or might not complete successfully because the calls can become disconnected. If you must use a PBX, do not route the telephone extension through a switchboard; instead, provide a direct-dial analog number.

Chapter 6

Rack Configuration Planning

Make sure that the ftServer T40 CO systems, DC-to-AC inverters, and optional components, such as an LCD monitor unit and tape drives, fit into the vertical space available in the rack.

To determine the vertical space used

1. In the Quantity column of [Table 6-1](#), enter the number of each component.
2. In each row, multiply the value in the Component Height column by the Quantity, and enter the subtotal in the Cumulative Height column.
3. Add the values in the Cumulative Height column together and write the resulting value in the bottom row. Compare this value to the height of your rack as measured in rack units (U).

Table 6-1. Rack Space Usage Calculation

Component	Component Height		Quantity	Cumulative Height
ftServer T40 CO system	4U	x		
Two DC-to-AC inverters	3U	x		
KVM switch	†	x		
Tape drive enclosure	†	x		
LCD monitor unit	1U	x		
Storage enclosures	†			
Total Height				

† See the *Stratus ftServer Systems: Peripherals Site Planning Guide* (R582) for the height of optional components you purchase from Stratus.

Appendix A

System Specifications

For system specifications see:

- [“System Specifications” on page A-1](#)
- [“DC-to-AC Inverter Specifications” on page A-5](#)

NOTES _____

1. The system temperature and humidity requirements, defined in [Table A-1](#) and [Table A-2](#), are the **minimum** requirements the site must provide.
2. The temperature and humidity requirements for optional components are provided in the *Stratus ftServer Systems: Peripherals Site Planning Guide (R582)*.

System Specifications

The following figures show front and rear views of the systems.

- [Figure A-1](#) shows the front of an ftServer T40 CO system, mounted in a rack with its bezel pulled forward.
- [Figure A-2](#) shows the rear of an ftServer T40 CO system, specifying the locations of the connectors at the rear of the system.

[Table A-1](#) lists the specifications for ftServer T40 CO systems.

Figure A-1. ftServer T40 CO System - Front View

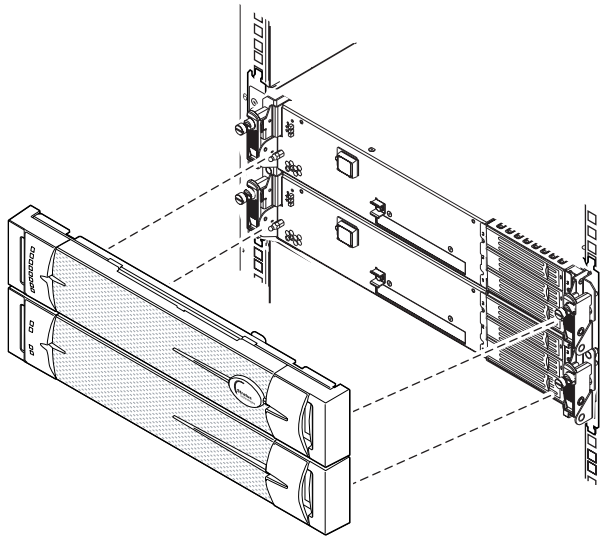

asys009

Figure A-2. ftServer T40 CO System - Rear View

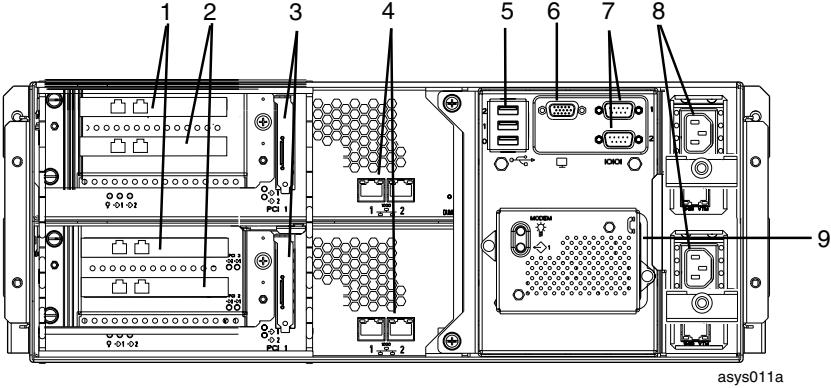

- 1 PCI slot 3
- 2 PCI slot 2
- 3 PCI slot 1
- 4 System 10/100/1000-Mbps Ethernet ports (4)
- 5 USB ports (3)
- 6 VGA (monitor) port
- 7 Serial (COM) ports (2)
- 8 Power receptacles (2)
- 9 Modem (telephone line) port

Table A-1. System Specifications

Power	
Input power	A-side enclosure: 600W B-side enclosure: 600W
Nominal input voltage (AC)	100-230 volts +/- 10% 240VAC+ 6%/-10%; 50/60 Hz
Protective earth ground current	3.5 milliamperes maximum for each AC power cord
Physical Dimensions	
Height	7.0 in. (17.78 cm; 4U)
Width	17.50 in. (44.45 cm)
Depth	30 in. (76.2 cm), excluding screws and bezel
Weight, including 8 DIMMS, 4 processors, and 6 disks	Two enclosures: 110 lb (49.9 kg), fully loaded Rails and shelf unit: 13.8 lb (6.26 kg)

Table A-1. System Specifications (Continued)

Environmental	
Operating temperature	40° F to 104° F (4.5° C to 40° C) -200 ft to 6000 ft (-61m to 610m) 40° F to 95° F (4.5° C to 35° C) 6000 ft to 8000 ft (-1828.8m to 2438.4m) 40° F to 86° F (4.5° C to 30° C) 8000 ft to 10000 ft (-2438.4m to 3048m)
Storage temperature	-38° F to 140° F (-40° C to 60° C), vented
Operating altitude	0 ft to 10,000 ft (0m to 3,048m)
Maximum rate of temperature change during operation	53° F/hr (12° C/hr)
Relative humidity during operation	10% to 80% (noncondensing)
Relative humidity during storage	5% to 95%
Heat dissipation	4095 BTUs per hour
Air cleanliness	Meets ISO 14644-1 class 8 standards
Features	
Processors	Two Intel® Xeon® 3.2 GHz processors with Hyper-Threading Technology in each CPU-I/O enclosure
Memory	Eight physical dual data rate (DDR) inline memory module (DIMM) slots in each CPU-I/O enclosure
Ports	Two 10/100/1000-Mbps Ethernet ports in each CPU-I/O enclosure Two AC power connectors, one VGA port, two serial ports, and three USB ports
PCI slots	One low-profile PCI adapter slot and two full-height PCI adapter slots, each operating at 64-bits and 100 MHz, all user-configurable, in each CPU-I/O enclosure
Disk drives	Three Serial ATA (SATA) disk drives in each CPU-I/O enclosure

DC-to-AC Inverter Specifications

Tables A-2 lists the specifications for the AA-P86600 DC-to-AC inverter.

Table A-2. AA-P86600 DC-to-AC Inverter Specifications

Environmental	
Operating ambient temperature	-20°C (-4°F) to +55°C (131°F)
Storage temperature range	-50° (-58°F) to +85°C (185°F)
Humidity range	Max 95% non-condensing
Mechanical	
Ventilation air	Internal fan
Mounting	3U rack height in rack mount frame, no additional clearance required top or bottom
Weight	12 lb (5.44kg)
DC-Power	
Nominal input voltage	48
Minimum (VDC)	42.75
Maximum (VDC)	56.7
Maximum input current	50 Amps DC
Protection	Input undervoltage and overvoltage protection. Output overload and short-circuit protection.
Inrush current controlled	Less than 50 Amps
AC Output Specifications	
Waveform	Sinusoidal
THD	< 1% typical
Output voltage	120 VAC/60 Hz
Voltage regulation	Better than 2%
Frequency stability	Controlled better than 0.01% stability
Isolation	Fully isolated input to output
Power rating	1.5 kVA maximum, over full temperature range

Table A-2. AA-P86600 DC-to-AC Inverter Specifications (Continued)

Peak output current into nonlinear load	36 Amps peak maximum for 120VAC
DC content	10mV maximum
Power factor	Linear – powers all loads with 0 leading to 0 lagging PF Non-linear – Rectified loads with up to 2.8 crest factor at full load
Motor starting	4 kVA output for 10 seconds minimum

Appendix B

Electrical Circuit and Wiring Information

For electrical circuit and wiring information that you need to provide to the contractor and/or facilities personnel responsible for wiring the power at the system installation site, see:

- [“Fault Protection Requirements” on page B-1](#)
- [“Grounding Considerations” on page B-1](#)
- [“Circuit Wiring Diagrams” on page B-2](#)
- [“Electrical Power Connectors” on page B-12](#)

Fault Protection Requirements

Each enclosure in ftServer systems contains internal fault/overload current protection. The two DC inputs to each DC inverter CRU are protected by fuses for protection against internal faults. However, the system relies on the power distribution system at your site for protection against potential faults in the power cords.



CAUTION

You must provide an over-current protection device having a rating of 100 VDC, 60 A in each power distribution branch feeding the system.

Grounding Considerations

The system obtains an earth reference ground through independent ground connections to the cabinet frame. Ensure that a high-integrity safety-ground conductor is installed as part of the wiring system (in accordance with Bellcore standards). The international safety standard (EN-60950) for electronic data processing (EDP) equipment also requires a ground conductor, but calls it a potential earth (PE) ground. Depending upon local conditions, ground potentials may differ between the system cabinet and any peripheral devices connected to the system cabinet.

The system cabinets must connect to a common ground point (ground window) to ensure signal integrity and the safety-ground connection. To meet this requirement, a

cabinet is connected to the ground window by one or two green-wire safety-ground conductor leads (#4 gauge wire), each of which can handle 60A fault current.

As shown in [Figure B-1](#), a *star ground* is often used to obtain the same earth reference ground. Each earth reference ground, such as the system base ground, is returned separately to a common point where a zero-volt (0V) earth ground exists. The star ground ensures that all equipment is at the same potential and that no noise or safety problems associated with an unpredictable or uncharacterized grounding system will occur.

Figure B-1. Star Ground Example

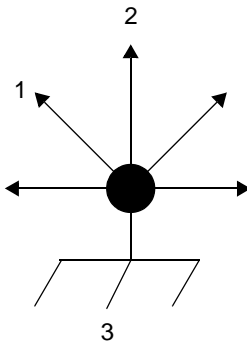

- 1 To monitor
- 2 To ftServer system
- 3 Earth reference ground (0V)

Circuit Wiring Diagrams

For circuit-wiring information, see the following topics:

- [“DC Circuit Wiring” on page B-3](#)
- [“DC Power Cables and Connectors” on page B-4](#)
- [“AC Circuit Wiring” on page B-4](#)

DC Circuit Wiring

Figure B-2 shows a schematic diagram of DC power for the ftServer T40 CO system.

Figure B-2. DC System Wiring

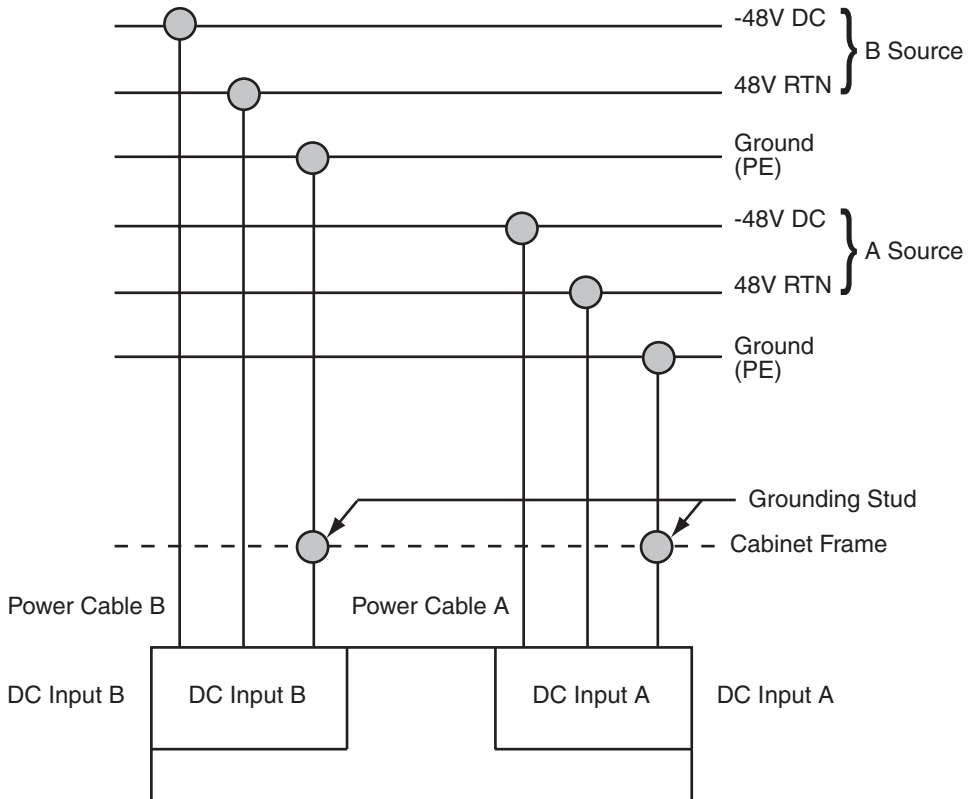

tlc074

DC Power Cables and Connectors

Stratus supplies tested and approved cables and connectors for the ftServer T40 CO system. [Table 4-1](#) provides descriptions and part numbers.



WARNING

User-supplied power or ground cables must meet the needs of the ftServer system and must comply with local safety codes and requirements.

NOTE

User-supplied DC power cables that connect directly from the CO supply to the DC inverter's DC input cable must use an Anderson Power Products® connector (Anderson part number SBS50BLU#6-BK) and two contacts (Anderson part number 1339G2-BK) at the inverter end.

User-supplied DC power cables that connect directly from the CO supply to the rear of the DC inverter must use a FCI- Burndy® ring lug connector (Burndy part number YAV6CL2TC14FX) at the inverter end.

AC Circuit Wiring

The following circuit wiring diagrams show how the hot, ground, and/or neutral AC signals should be connected to the power input plug to optional AC-powered components:

- [Figure B-4](#) illustrates a single-phase 120-volts AC circuit connection.
- [Figure B-5](#) illustrates a single-phase 240-volts AC circuit connection.
- [Figure B-6](#) illustrates a split-phase 120/240-volts AC circuit connection.
- [Figure B-7](#) illustrates a three-phase 208-volts AC, Y-, or Δ -source circuit connection, phase-to-neutral.
- [Figure B-8](#) illustrates a three-phase 208-volts AC, Y-, or Δ -source circuit connection, phase-to-phase.
- [Figure B-9](#) illustrates a three-phase 380V AC, Y-, or Δ -source circuit connection, phase-to-neutral.

In the diagrams in this appendix, the power inputs for ftServer T40 CO systems are labeled X and Y, as shown in [Figure B-3](#), to eliminate any ambiguities in the nomenclature. For single-phase applications, the X input is connected to the L (Line) *hot* input, and the Y input is connected to the N (Neutral) input. However, for split-phase or three-phase applications, the X and Y inputs are connected to L1, L2, or L3 (separate lines). Therefore, for split-phase or three-phase applications, both X and Y can be electrically hot with respect to the system base (earth reference ground). [Figure B-3](#) shows the physical locations of the X and Y inputs on the system base.

Figure B-3. Power Input Labeling

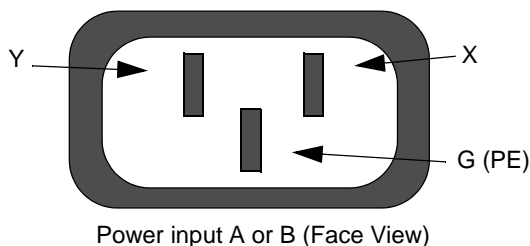

Figure B-4 shows a single-phase 120-volts AC circuit connection. Note that this application requires a single-pole circuit breaker.

Figure B-4. Single-Phase 120-Volts AC Circuit Connection

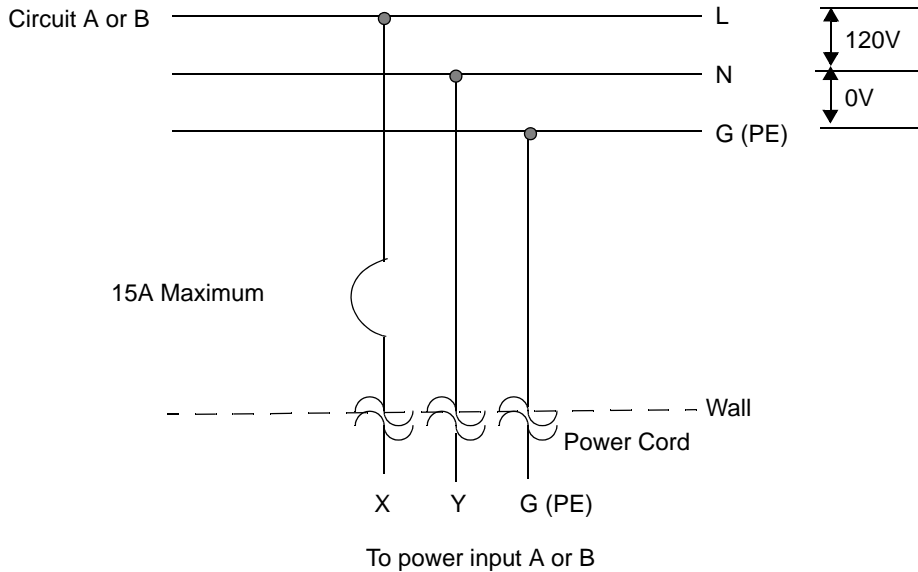

Figure B-5 shows a single-phase 240-volts AC circuit connection. Note that this application requires a single-pole circuit breaker.

Figure B-5. Single-Phase 240-Volts AC Circuit Connection

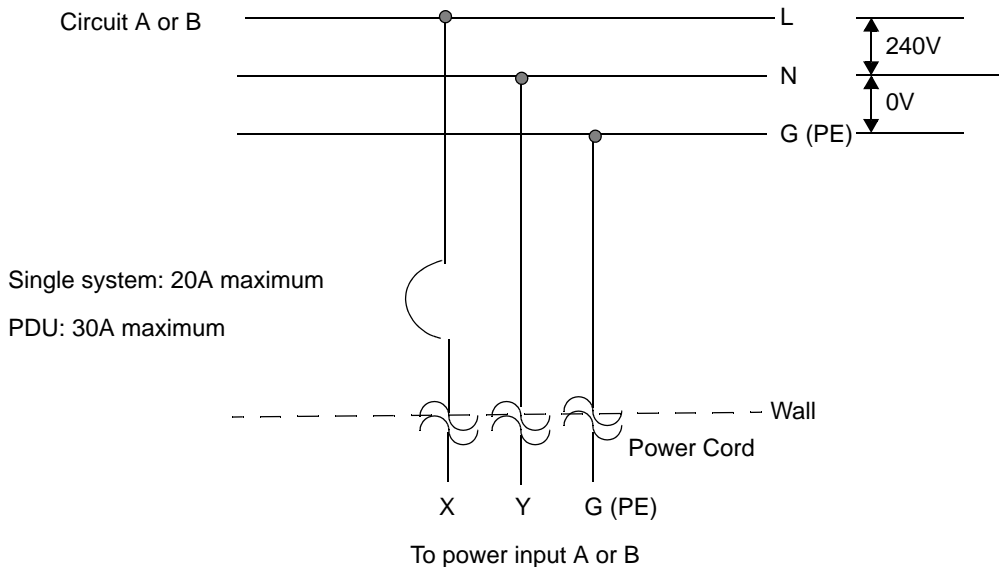

Figure B-6 shows a split-phase 120/240-volts AC circuit connection. Note that this application requires a double-pole circuit breaker.

Figure B-6. Split-Phase 120/240 Volts AC Circuit Connection

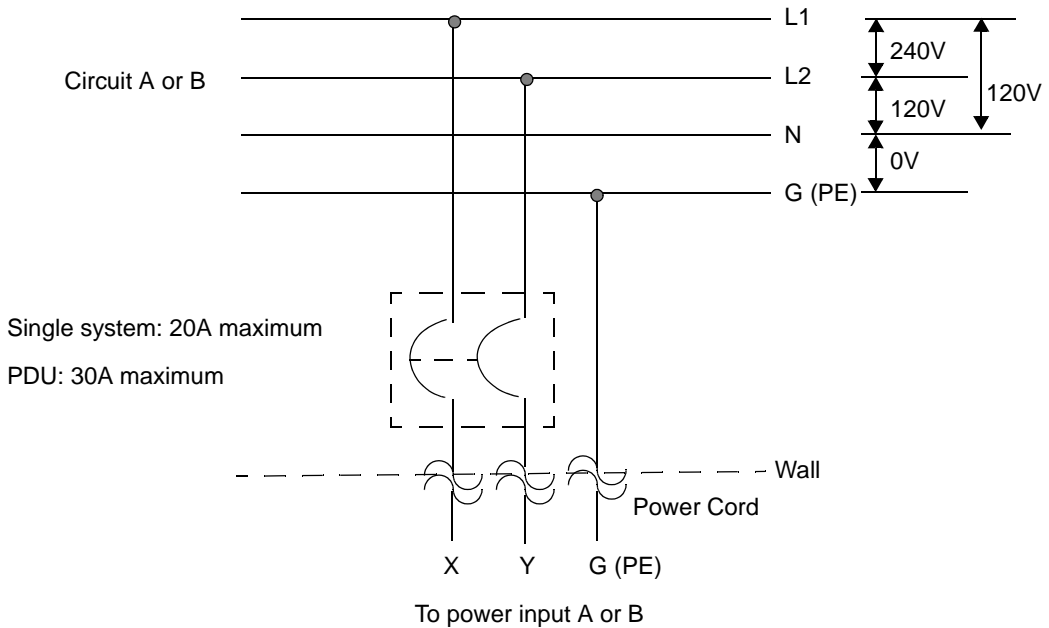

Figure B-7 shows a three-phase 208-volts AC, Y-, or Δ -source circuit connection, which is a phase-to-neutral source connection. Note that the X input on the system can be connected from L1, L2, or L3. This application requires a single-pole circuit breaker.

Figure B-7. Three-Phase 208-Volts AC, Y-, or Δ -Source Circuit Connection, Phase-to-Neutral

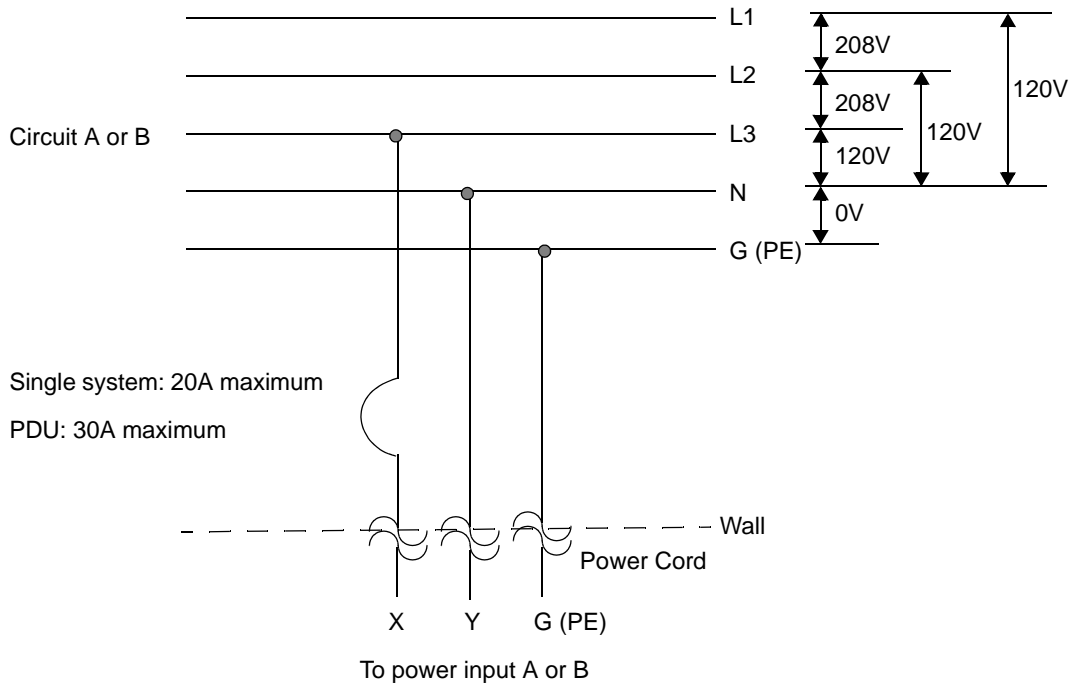

Figure B-8 shows a three-phase 208-volts AC, Y-, or Δ -source circuit connection, which is a phase-to-phase source connection. Note that the X and Y inputs on the system can be connected from L1 and L2, L2 and L3, or L1 and L3. This application requires a double-pole circuit breaker.

Figure B-8. Three-Phase 208-Volts AC, Y-, or D-Source Circuit Connection, Phase-to-Phase

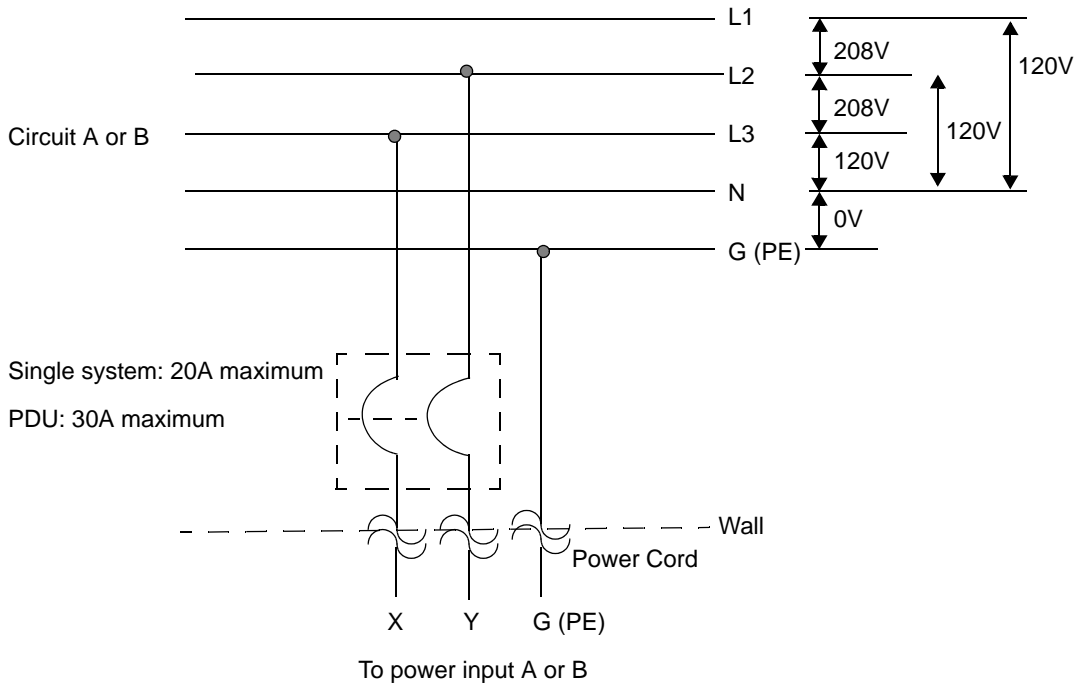
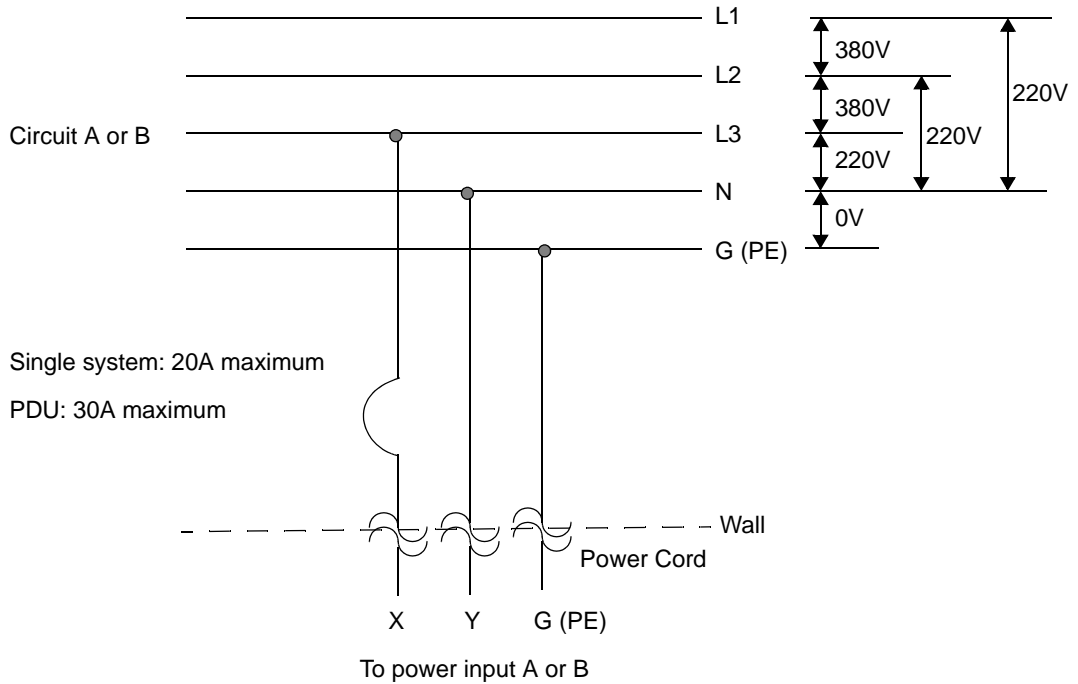

Figure B-9 shows a three-phase 380V AC, Y-, or Δ -source circuit connection, which is a phase-to-neutral source connection. Note that the system's X input can be connected to L1, L2, or L3. This application requires a single-pole circuit breaker.

Figure B-9. Three-Phase 380V AC, Y-, or D-Source Circuit Connection, Phase-to-Neutral



Electrical Power Connectors

Table B-1 describes the connectors on the AC power cords that Stratus supplies for optional devices, such as tape drives.

Table B-1. Connectors for AC Power Outlets



Connector	Configuration	Rating	Description
NEMA L6-20		20A, 250 volts AC	2-pole, 3-wire
NEMA 5-15		15A, 125 volts AC	2-pole, 3-wire
NEMA L6-30		30A, 250 volts AC	2-pole, 3-wire
CEE (7) VII		20A, 250 volts AC	2-pole, 3-wire
CEI-23-16		16A, 250 volts AC	2-pole, 3-wire
SI 32/1971		16A, 250 volts AC	2-pole, 3-wire

Table B-1. Connectors for AC Power Outlets (Continued)

Connector	Configuration	Rating	Description
IEC 60309 (formerly IEC 309)		16-20A, 250 volts AC	2-pole, 3-wire
SABS 164-1:1992		16A, 250 volts AC	2-pole, 3-wire
BS 1363/A		13A, 250 volts AC	2-pole, 3-wire
SEV 1011-S24507		10A, 250 volts AC	2-pole, 3-wire
AS/NZS 3112-1993		15A, 250 volts AC	2-pole, 3-wire
SAA/3/15 AS/NZS 3112-1993		15A, 250 volts AC	2-pole, 3-wire

Table B-1. Connectors for AC Power Outlets *(Continued)*

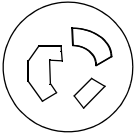
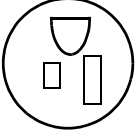
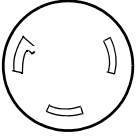
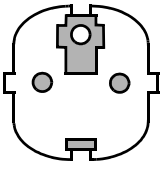
Connector	Configuration	Rating	Description
GB1002-1996		10A, 250 volts AC	2 pole, 3-wire

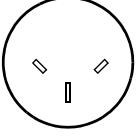
Appendix C

Standards Compliance

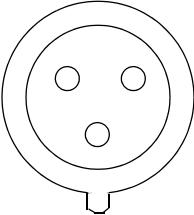
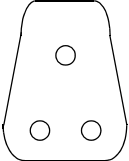
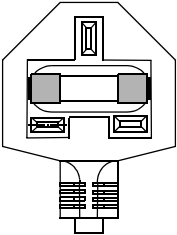
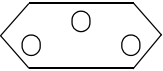
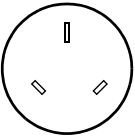
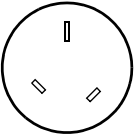
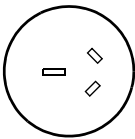
ftServer T40 CO systems comply with the electromagnetic interference (EMI), immunity, safety, and noise regulations listed in Tables C-1 through C-5. All necessary agency labels are on the system.

NOTES _____

1. This system must be configured with the components listed and described in the product configuration specifications. Deviations from this list of components will void agency certification.
2. You must install all wiring, including power and communications cables, in compliance with local and national electrical code (in the United States, national electrical code NFPA 70). In addition, you must use shielded communications cables to remain in compliance with Federal Communications Commission (FCC) and other international Electromagnetic compatibility (EMC) regulations.
3. All EMC emissions compliance tests are performed at a third-party certified test laboratory. You can obtain compliance reports for these tests from your Stratus account representative, who will contact the Product Compliance Group in the Stratus engineering organization.

Table C-1. EMI Standards

Standard	Description	Country/Region
FCC Part 15 Class A	Code of Federal Regulations 47 (1998) Class A	North America
EN 55022	Limits and methods of measurement of radio disturbance characteristics of Information Technology Equipment	European Union
AS/NZS 3548	Limits and methods of measurement of radio disturbance characteristics of Information Technology Equipment	Australia/New Zealand
CNS13438	Chinese National Standard 13438	Taiwan
VCCI Class A	Voluntary Control Council for Interference by Information Technology Equipment	Japan

Table C-2. Immunity Standards

Standard	Description	Country/Region
EN 50082-1	Generic Immunity Standard, Electromagnetic Compatibility, Residential, Commercial, and Light Industrial	European Union
EN 55024	Limits and methods of measurement of immunity characteristics of Information Technology Equipment	European Union

Table C-3. Safety Standards

Standard	Description	Country/Region
UL 60950	Safety of Information Technology Equipment	North America
EN 60950	Safety of Information Technology Equipment	European Union

Table C-4. Noise Standards

Standard	Description	Country/Region
ISO 9614-2	Acoustics. Determination of Sound Power Levels of Noise Source using Sound Intensity	European Union
ISO 7779	Measurements of Airborne Noise emitted by Computers and Business Equipment	European Union

Table C-5. NEBS (Telecommunications) Standards

Standard	Description	Country/Region
GR-1089-CORE	Specifies the Electromagnetic Compatibility (EMC) and electrical safety necessary for equipment to perform reliably and safely in a network environment of a typical telecommunication service provider.	United States of America
GR-63-CORE	Specifies the minimum spatial and environmental criteria for all new telecommunications equipment used in Central Offices (COs) and other environmentally controlled telephone equipment spaces	United States of America

VCCI Note

この装置は、情報処理装置等電波障害自主規制協議会（VCCI）の基準に基づくクラスA 情報技術装置です。この装置を家庭環境で使用すると電波妨害を引き起こすことがあります。この場合には使用者が適切な対策を講ずるよう要求されることがあります。

BSMI Note**警告使用者**

這是甲類的資訊產品、在居住的環境中使用時、可能會造成射頻干擾、在這種情況下、使用者會被要求採取某些適當適對策

Index

A

ActiveService Network (ASN). *See* ASN
AS/NZS 3112-1993 connector, B-13
ASN, site planning, 1-3, 3-2, 5-3

B

BS 1363/A connector, B-13

C

cabinets
 requirements, 2-1
cables
 Ethernet network, 5-1
 planning for, 3-2
 supplied, 3-2
 telephone, 3-2
CAC, getting assistance, 1-2
CEE (7) VII connector, B-12
CEI-23-16 connector, B-12
checklist for site planning, 1-2
circuit, electrical
 DC wiring, B-3
 planning information, B-1
 wiring diagrams, B-4
compliance, standards, C-1
connectors
 AC, 4-4, 4-5
 Anderson, 4-3, B-4
 Burndy, 4-3, B-4
 DC, B-4
 DC power, B-4
cooling requirements, 3-1
 See also environmental requirements, 3-1
Customer Assistance Center. *See* CAC

D

DC inverter
 cords
 ground, 4-6
DC power, 4-1
DC-to-AC inverter
 ground cords, 4-6
DC-to-AC inverters
 AC output
 supported devices, 4-4
 cables
 DC input, 4-6
 cords
 AC output jumper, 4-6
 inverter AC Y output, 4-6
 output cabling, 4-5
 T-plug adapter, 4-6
documentation, ordering, 1-6
dust contamination, 3-1

E

electrical connectors, B-12
electrical grounding, B-1
electrical wiring, B-1
electromagnetic interference, C-2
environmental requirements
 operating humidity, A-4
 operating temperature, A-4
 storage humidity, A-4
Ethernet network cables, 5-1

G

GB1002-1996 connector, B-14
grounding the system, 2-2, B-1

H

hubs, network, 3-2

I

- IEC 309 connector, B-13
- IEC 60309 connector, B-13
- immunity regulations, C-2
- ISO 14644-1 class 8 standards, 3-1

J

- jacks, Ethernet, 3-2

L

- LCD monitor units
 - power cords, 4-9

M

- monitors
 - power cords, 4-9
 - requirements, 2-4

N

- NEMA 5-15 connector, B-12
- NEMA L6-20 connector, B-12
- NEMA L6-30 connector, B-12
- network (Ethernet) cables, 5-1
- noise regulations, C-2

P

- power (AC)
 - cords
 - LCD monitor units, 4-9
 - monitors, 4-9
 - storage enclosures, 4-9
 - tape drives, 4-9
 - electrical requirements, 4-6
 - service requirements, 4-6, 4-7, 4-8
 - A-side, 4-8
 - B-side, 4-8
- power (DC)
 - cords, 4-6
 - electrical requirements, 4-5
 - service requirements, 4-5

R

- racks
 - planning, 6-1
 - requirements, 2-1
- room requirements, 3-1

S

- SAA/3/15 AS/NZS 3112-1993 connector, B-13
- SABS 164-1:1992 connector, B-13
- safety regulations, C-2
- SEV 1011-S24507 connector, B-13
- SI 32/1971 connector, B-12
- single-phase circuit connections
 - 120 V AC, B-6
 - 240 V AC, B-7
- site planning checklist, 1-2
- space planning, 3-1
- specifications
 - AC power, 4-5, 4-6
 - DC-to-AC inverter, A-5
 - rack-mountable system, A-1
- split-phase circuit connections
 - 120–240 V AC, B-8
- standards compliance, C-1
- star ground, B-2
- Stratus Customer Assistance Center. *See* CAC
- switches, network, 3-2

T

- tape drives
 - BHFCA-EY, 4-7
 - external AC power requirements, 4-7
 - BHGCA-EY, 4-7
 - external AC power requirements, 4-7
 - ER-SL1AA-YF, 4-7
 - external AC power requirements, 4-7
 - ER-SL2AA-YF, 4-7
 - external AC power requirements, 4-7
 - power cords, 4-9
 - T521, 4-7
 - external AC power requirements, 4-7
 - T522, 4-7
 - external AC power requirements, 4-7
- technical support. *See* CAC
- telephone lines
 - for ASN modem assembly, 1-3, 5-3
 - for support calls, 1-3, 5-3

three-phase circuit connections

208 V AC, B-9, B-10

380 V AC, B-11

W

wiring, electrical, B-1

