

Stratus ftServer V 2404, V 4408, and V 6408 Systems: Site Planning Guide

Stratus Technologies
R645-00

Notice

The information contained in this document is subject to change without notice.

UNLESS EXPRESSLY SET FORTH IN A WRITTEN AGREEMENT SIGNED BY AN AUTHORIZED REPRESENTATIVE OF STRATUS TECHNOLOGIES, STRATUS MAKES NO WARRANTY OR REPRESENTATION OF ANY KIND WITH RESPECT TO THE INFORMATION CONTAINED HEREIN, INCLUDING WARRANTY OF MERCHANTABILITY AND FITNESS FOR A PURPOSE. Stratus Technologies assumes no responsibility or obligation of any kind for any errors contained herein or in connection with the furnishing, performance, or use of this document.

Software described in Stratus documents (a) is the property of Stratus Technologies Bermuda, Ltd. or the third party, (b) is furnished only under license, and (c) may be copied or used only as expressly permitted under the terms of the license.

Stratus documentation describes all supported features of the user interfaces and the application programming interfaces (API) developed by Stratus. Any undocumented features of these interfaces are intended solely for use by Stratus personnel and are subject to change without warning.

This document is protected by copyright. All rights are reserved. Stratus Technologies grants you limited permission to download and print a reasonable number of copies of this document (or any portions thereof), without charge, for your internal use only, provided you retain all copyright notices and other restrictive legends and/or notices appearing in the copied document.

Stratus, the Stratus logo, ftServer, the ftServer logo, Continuum, StrataLINK, and StrataNET are registered trademarks of Stratus Technologies Bermuda, Ltd.

The Stratus Technologies logo, the Continuum logo, the Stratus 24 x 7 logo, ActiveService, ftScalable, and ftMessaging are trademarks of Stratus Technologies Bermuda, Ltd.

RSN is a trademark of Lucent Technologies, Inc.

All other trademarks are the property of their respective owners.

Manual Name: *Stratus ftServer V 2404, V 4408, and V 6408 Systems: Site Planning Guide*

Part Number: R645

Revision Number: 00

OpenVOS Release Number: 17.1.0

Publication Date: April 2011

Stratus Technologies, Inc.

111 Powdermill Road

Maynard, Massachusetts 01754-3409

© 2011 Stratus Technologies Bermuda, Ltd. All rights reserved.

Contents

Preface	vii
----------------	-----

1. Site Planning for ftServer V 2404, V 4408, and V 6408 Systems	1-1
Site Planning Overview	1-1
Site Planning for Fault-Tolerant Systems	1-2
Planning for Cables	1-3
Site Planning Checklist	1-5
Preparing to Install a System	1-7
Preparing to Take Delivery of a System	1-8
Moving the System to the Installation Site	1-8
System Documentation	1-9
Safety Notices	1-10

2. AC Power Planning	2-1
AC Power Overview	2-1
Redundant Power Sources	2-1
AC Power and HVAC Worksheets	2-2
Selecting a UPS Unit for ftServer Systems	2-4
AC Power Connections to Qualified UPS Models	2-7
Power Cord Summary	2-7
Main Cabinet Ground Cables	2-8

3. Space Planning and Component Location	3-1
RSN Connections	3-1
Fibre Channel Connections	3-2
UPS Connections	3-3
Component Location and Cabling Summary	3-3
Room Requirements	3-5
Cabinet Mounting and Leveling Considerations	3-7
Creating a Floor Plan	3-8

4. Other Infrastructure Requirements	4-1
Telephone Lines	4-1
Network Connections	4-2
Site Ethernet Networks	4-2
Ethernet Subnet Requirements	4-3
Maintenance Network	4-3
System PC Console	4-4

5. Supported Configurations	5-1
Cabinet Configurations	5-1

Appendix A. System Specifications	A-1
System Specifications	A-1
AAP87600V PDU Specifications	A-7

Appendix B. Electrical Circuit and Wiring Information	B-1
Fault Protection Requirements	B-1
Grounding Considerations	B-1
Circuit Wiring Diagrams	B-2
Electrical Power Connectors	B-8

Appendix C. Standards Compliance	C-1
Electronic Interference, Immunity, Safety, and Noise Level	
Standards Compliance	C-1
Toxic and Hazardous Substances and Elements Disclosure	C-6

Index	Index-1
--------------	---------

Figures

Figure 1-1.	Cabling Considerations with RSN Dialup Console Server and Modem	1-4
Figure 1-2.	Cabling Considerations with RSN Internet Console Server	1-5
Figure 3-1.	Space-Planning Considerations	3-7
Figure 3-2.	System Equipment Templates	3-9
Figure 3-3.	Site-Layout Grid	3-10
Figure 5-1.	Base ftServer V 4408 or V 6408 System	5-2
Figure 5-2.	Fully Configured ftServer V 4408 or V 6408 System	5-3
Figure 5-3.	ftServer V 2404 System Without Network I/O Enclosure	5-4
Figure A-1.	CPU-I/O Enclosures: Front View	A-2
Figure A-2.	ftServer CPU-I/O Enclosures: Rear View	A-3
Figure A-3.	AAP87600V PDU	A-7
Figure B-1.	Star Ground Example	B-2
Figure B-2.	Power Input Labeling	B-3
Figure B-3.	Single-Phase 120V AC Circuit Connection	B-3
Figure B-4.	Single-Phase 240V AC Circuit Connection	B-4
Figure B-5.	Split-Phase 120/240 Volts AC Circuit Connection	B-5
Figure B-6.	Three-Phase 208V AC, Y-, or D-Source Circuit Connection, Phase-to-Phase	B-6
Figure B-7.	Three-Phase 380V AC, Y-, or D-Source Circuit Connection, Phase-to-Neutral	B-7

Tables

Table 1-1.	Ethernet PCI Adapters	1-6
Table 1-2.	ftServer V 2404, V 4408, and V 6408 System Documentation	1-9
Table 2-1.	Worksheet for Planning Site AC Outlets and Cord Lengths	2-3
Table 2-2.	Work Sheet for Site AC Power and HVAC Requirements	2-4
Table 2-3.	Qualified Chloride UPS Models	2-5
Table 2-4.	Qualified APC UPS Models	2-6
Table 2-5.	UPS to PDU AC Power Cords for Qualified UPS Models	2-7
Table 2-6.	Power Cords	2-8
Table 2-7.	Main Cabinet Ground Cable	2-8
Table 3-1.	Cord and Cable Summary	3-3
Table 3-2.	Location of V Series System Components	3-4
Table 4-1.	Ethernet Subnet Requirements	4-3
Table A-1.	Cabinet Dimensions	A-4
Table A-2.	V 2404, V 4408, and V 6408 System CPU-I/O Enclosure: Specifications	A-5
Table A-3.	AAP87600V PDU: Specifications	A-8
Table B-1.	Connectors for AC Power Outlets	B-8
Table C-1.	Compliance Standards for ftServer V 2404, V 4408, and V 6408 Systems (Class A)	C-2

Preface

The *Stratus ftServer V 2404, V 4408, and V 6408 Systems: Site Planning Guide* (R645) documents the site requirements and customer responsibilities related to preparing a site for the installation of V 2404, V 4408, and V 6408 systems.

This document is intended for those responsible for preparing a site for the installation of an ftServer V 2404, V 4408, or V 6408 system.

Revision Information

This is the first edition of this document.

Notation Conventions

This document uses the notation conventions described in this section.

Warnings, Cautions, and Notes

Warnings, cautions, and notes provide special information and have the following meanings:



WARNING _____

A warning indicates a situation where failure to take or avoid a specified action could cause bodily harm or loss of life.



CAUTION _____

A caution indicates a situation where failure to take or avoid a specified action could damage a hardware device, program, system, or data.

NOTE _____

A note provides important information about the operation of an ftServer system.

Getting Help

If you have a technical question about ftServer system hardware or software, try these online resources first:

- **Online documentation at the StrataDOC Web site.** Stratus provides complimentary access to StrataDOC, an online-documentation service that enables you to view, search, download, and print customer documentation. You can access StrataDOC at the following Web site:

<http://stratadoc.stratus.com>

A copy of StrataDOC on supported media for your system is included with this release. To order additional copies of the StrataDOC media or to obtain copies of printed manuals, do one of the following:

- If you are in North America, call the Stratus Customer Assistance Center (CAC) at (800) 221-6588 or (800) 828-8513, 24 hours a day, 7 days a week.
 - If you are located outside North America, contact your nearest Stratus sales office, CAC office, or distributor; for CAC phone numbers outside the U.S., see <http://www.stratus.com/support/cac/index.htm>.
 - If your system is connected to the Remote Service Network (RSN™), issue the OpenVOS `maint_request` command at the system prompt. Complete the on-screen form with all of the information necessary to process your manual order. You can use this command only on OpenVOS systems.
- **Online support from Stratus Customer Service.** You can find the latest technical information about an ftServer system through online product support at the Stratus Technical Support Web site:

<http://www.stratus.com/support/technics.htm>

If you are unable to resolve your questions with the help available at these online sites, and the ftServer system is covered by a service agreement, please contact the Stratus Customer Assistance Center (CAC) or your authorized Stratus service representative. For information about how to contact the CAC, see the following Web site:

<http://www.stratus.com/support/cac/>

Commenting on the Documentation

To provide corrections and suggestions on the documentation, send your comments in one of the following ways:

- By clicking the **site feedback** link at the bottom of a Help topic. Information to identify the topic is supplied in the StrataDOC Web Site Feedback form.

- By email to Comments@stratus.com. If it is possible, please include specific information about the documentation on which you are commenting:
 - For a printed document or a document in PDF format, include the title and part number from the Notice page and the page numbers.
 - For online documentation, include the Help subject and topic title.

If you are connected to an OpenVOS system, you can comment on this document by using the command `comment_on_manual`. To use the `comment_on_manual` command, your system must be connected to the RSN.

The `comment_on_manual` command is documented in the document *OpenVOS System Administration: Administering and Customizing a System* (R281) and the *OpenVOS Commands Reference Manual* (R098). There are two ways you can use this command to send your comments.

- If your comments are brief, type `comment_on_manual`, press `[Enter]` or `[Return]`, and complete the data-entry form that appears on your screen. When you have completed the form, press `[Enter]`.
- If your comments are lengthy, save them in a file before you issue the command. Type `comment_on_manual` followed by `-form`, then press `[Enter]` or `[Return]`. Enter this document's part number, R645, then enter the name of your comments file in the `-comments_path` field. Press the key that performs the `CYCLE` function to change the value of `-use_form` to `no` and then press `[Enter]`.

NOTE

If `comment_on_manual` does not accept the part number of this document (which may occur if the document is not yet registered in the `manual_info.table` file), you can use the `mail` request of the `maint_request` command to send your comments.

Your comments (along with your name) are sent to Stratus over the RSN.

This information will assist Stratus Information Development in making any needed changes to the `ftServer` system documentation. Your assistance is most appreciated.

Regulatory Notice

[Appendix C, "Standards Compliance"](#) provides all regulatory notices.

Chapter 1

Site Planning for ftServer V 2404, V 4408, and V 6408 Systems

For an overview of required information and tasks you need to perform to prepare a site for ftServer V 2404, V 4408, and V 6408 systems, see:

- [“Site Planning Overview” on page 1-1](#)
- [“Site Planning for Fault-Tolerant Systems” on page 1-2](#)
- [“Planning for Cables” on page 1-3](#)
- [“Site Planning Checklist” on page 1-5](#)
- [“Preparing to Install a System” on page 1-7](#)
- [“System Documentation” on page 1-9](#)
- [“Safety Notices” on page 1-10](#)

Site Planning Overview

[Site planning for fault-tolerant systems](#) includes:

- [Electrical power planning](#)

Provide electrical power sources that meet the requirements of the system and optional components, including the purchase of a qualified [uninterruptible power supply \(UPS\)](#).
- [Space planning](#)

Plan the location of the system and external components to accommodate the lengths of the connecting cables.

Provide adequate space for the system or cabinet and for a desk or table to accommodate components outside a cabinet. Also provide enough space for servicing the systems and components.

Provide an environment that meets the system's requirements for ambient temperature and air quality.

- **Other Infrastructure requirements**

Understand Ethernet requirements. Provide sufficient network and telephone connection points.

Provide a PC to act as a **system PC console**. Stratus provides a serial cable for connecting the PC to the server. You must provide an Ethernet cable to connect the system PC console to the ftServer system.

Use the “**Site Planning Checklist**” on page 1-5 to track your site preparation progress.

For information about obtaining documents related to your ftServer system, see “**System Documentation**” on page 1-9.

During the site planning and preparation processes, work closely with your facilities group or contractor to determine space, power, and environmental requirements. Enlist their help to provide a suitable location with sufficient alternating current (AC) power, heating, ventilation and air conditioning (HVAC) capabilities, and network and telephone connections.

If your system is covered by a service agreement and you need help with site planning, contact the Stratus Customer Assistance Center (CAC) or your authorized Stratus service representative. If you have a contract with the CAC or your authorized Stratus service representative to install the system, contact them after you have prepared the installation site and moved the system to the site. For more information about the CAC, see **Getting Help** in the Preface or the <http://www.stratus.com/support/cac/> Web site.

See **Chapter 5, “Supported Configurations”** for illustrations of the rack configurations of your ftServer system and other rack-mounted components, and **Appendix A, “System Specifications”** for the specifications of the base ftServer systems and of PDUs. See the *Stratus ftServer Systems: Peripherals Site Planning Guide* (R582) for specifications of other components, both rack-mounted and external to the rack.

Site Planning for Fault-Tolerant Systems

Consider the following specific fault-tolerant features of ftServer systems as you plan the site:

- Lockstep technology means that the systems contain redundant hardware. The systems contain two enclosures, each containing a full computing environment that consists of a CPU element and an I/O element.

If a component in a CPU element malfunctions, the corresponding CPU element in the other enclosure, which is processing the same information in lockstep, continues processing without interruption. If a component in the I/O element malfunctions, the system fails operation over to the corresponding element in the other enclosure and continues to operate normally. The only consequences are

that the system is less fault tolerant, and any I/O throughput distributed between the enclosures may be reduced. To restore full fault tolerance, an enclosure can be replaced without taking the system offline.

- ftServer systems can connect to the Remote Service Network (RSN).

Connecting a system to the RSN allows the CAC or your authorized Stratus service representative to remotely diagnose, troubleshoot, and resolve problems online.

If you are using an AA-E96600 RSN dialup console server, the RSN bridge module connects to the RSN over a phone line and modem. If you are using an AA-E97700 RSN Internet console server, the RSN bridge module connects to the RSN over the Internet. See [“RSN Connections” on page 3-1](#) for more information.

Planning for Cables

At sites with solid (non-raised) floors, the cables exit from the top of the cabinet and are routed along the ceiling.

At sites with raised floors, the cables exit from the bottom rear of the cabinet and are routed under the floor.

To accommodate cables from your system, make sure to provide:

- One or two telephone lines as described in [“Telephone Lines” on page 4-1](#):
- Ethernet ports, switches, or hubs, as needed
- Two UPS units, within reach of the power cords from the system or PDUs
- For external components, AC wall outlets within reach of the power cords from the components

Make sure that cables you plan to connect to the system are long enough to reach between the system and external components or connections. For information about specific cables and power cords, see the following:

- [“Power Cord Summary” on page 2-7](#)
- [Chapter 3, “Space Planning and Component Location”](#)
- *Stratus ftServer Systems: Peripherals Site Planning Guide (R582)* for information about cable lengths for peripheral components

Figure 1-1 illustrates cabling considerations for systems with an AA-E96600 RSN dialup console server and modem.

Figure 1-1. Cabling Considerations with RSN Dialup Console Server and Modem

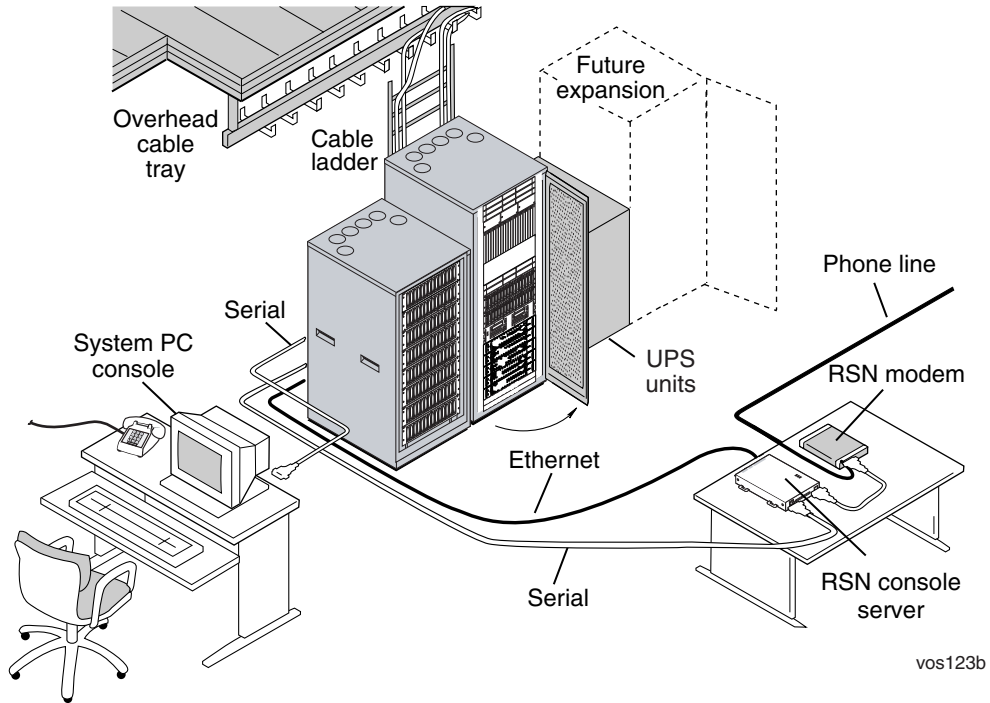
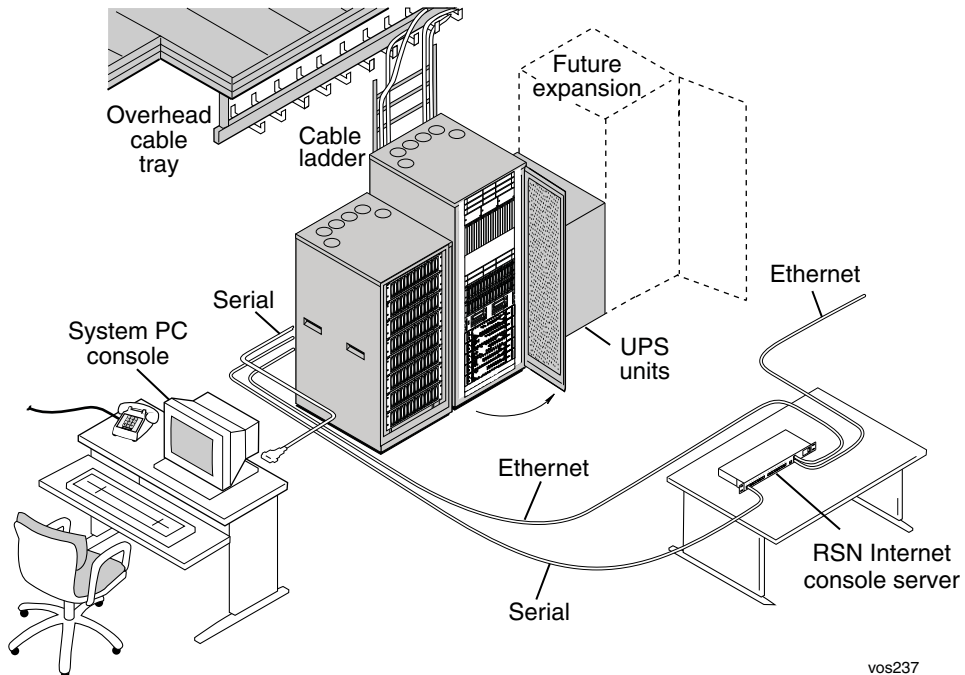

Figure 1-2 illustrates cabling considerations for systems with an AA-E97700 RSN Internet console server.

Figure 1-2. Cabling Considerations with RSN Internet Console Server



vos237

Site Planning Checklist

Referring to the information in this document, answer the following questions:

- Do you have a telephone and telephone line near the operator's station for voice communications when calling for support?

Planning for RSN Connectivity

- If you are using the AA-E97700 RSN Internet console server, do you have an Ethernet connection to the Internet?
- If you are using the AA-E97700 RSN Internet console server, do you have OpenVOS Release 17.1.0 or later installed?
- If you are using the AA-E96600 RSN dialup console server, do you have an external telephone line available for the RSN modem?

NOTE

A dedicated phone line for the RSN modem provides the most reliable service. RSN calls routed through a PBX may be slow due to load on the PBX, or may not complete successfully due to disconnections. If you must use a PBX, do not route the telephone extension through a switchboard; instead, provide a direct-dial analog number.

Planning for Optional Components

- The system contains four embedded 10/100/1000 megabits-per-second (Mbps) Ethernet ports. Will your system additionally include any of the following PCI adapters for network communications? If so, in [Table 1-1](#), indicate the total number of ports, and plan network connections for all Ethernet ports you will use.

Table 1-1. Ethernet PCI Adapters

Adapter	Total Number of Ports
U582V Quad-Port Gigabit Ethernet Adapter	4
U583V Quad-Port Fiber Gigabit Ethernet Adapter	4
U584V Dual-Port 10 Gigabit Ethernet Adapter †	2

† Not supported in V 2404 systems.

- Do you have a system PC console located at the installation site? Plan to keep the console located with the system.
- To plan for storage enclosures in your system, see the *Stratus ftServer Systems: Peripherals Site Planning Guide (R582)* for descriptions of the enclosures and the names of the required PCI adapters.

Planning AC Power

- Have you selected and purchased two UPS units for each ftServer system?
- What optional components will you use?
- What are the HVAC and AC power requirements of all optional components?
- What are the lengths and types of the power cords that are provided for the optional components?
- What type of AC receptacles do you need to provide?
- Is the AC power service wired properly?

Planning Space for Your System

- Will your system and its external components fit where you plan to place them?
- What are the lengths and types of the interface and communications cables that will connect to your system?
- Have you created a sketch of how you plan to arrange the system at the installation site? Consider the available cable lengths, the placement of external devices, and the location of network and voice communication connections.

On the sketch, show the following:

- Location of the system and its external components
- Power cords, and telephone and interface cables
- Locations of AC power receptacles, phone jacks, Ethernet jacks, switches, and hubs

NOTE _____

Make sure that all cords and cables are long enough to reach between their respective components and connectors. Route all cables out of the way of foot traffic.

Working with Other Groups

- Have you provided your facilities group and contractors with the sketch of how you plan to arrange the system and copies of the following?
 - [“Redundant Power Sources” on page 3-1](#)
 - [Appendix B, “Electrical Circuit and Wiring Information”](#)
 - Any notes you have about site planning
- Have you reviewed and discussed the requirements with the facilities personnel and contractors to ensure that all site modifications are understood and implemented?

If you have any questions about the number and types of components, contact your Stratus account executive or distributor.

Preparing to Install a System

To prepare for the installation of a system by a field engineer, perform the following tasks:

1. Complete all site preparation work, as described in [“Preparing to Take Delivery of a System” on page 1-8](#).

2. Take delivery of the system.
3. Move the system to its installation site, as described in [“Moving the System to the Installation Site” on page 1-8.](#)

Preparing to Take Delivery of a System

Before you take delivery of your system, perform the following tasks:

1. Secure traffic permits for the delivery vehicle and security clearances for moving the shipping container within your facility if necessary.
2. Determine a suitable delivery site with enough space for unloading the system.
3. Make sure that the delivery site will accommodate the delivery vehicle.

NOTE _____

Depending on the system configuration and the components you have ordered, a separate carton containing components may be shipped with your system.

When your system arrives, perform the following tasks:

- Contact the CAC or your authorized Stratus service representative.
- Check the Tip-N-Tell and Shockwatch motion sensors to determine if they have been activated. If a sensor has been activated, or if there is any damage, report it immediately to the carrier and to the CAC or your authorized Stratus service representative.
- Check the packing list. If you received the wrong shipment, or if the shipment is incomplete, report it immediately to the carrier and to the CAC or your authorized Stratus service representative.

Moving the System to the Installation Site

Before moving your system to the installation site, perform the following tasks:

NOTE _____

Moving a system requires **two** able-bodied persons.

1. Obtain a pallet jack to move your system from the delivery area to the installation site.
2. Check the dimensions of doorways and the load capacities of floors and elevators. You should walk the path over which you will move the system to ensure that it can be easily moved to the installation site. If your system will not fit through the doorways, you may need to arrange for rigging.

NOTE

Each cabinet is shipped on a pallet that is slightly larger than a standard door opening. A standard door opening is 35 in. (89 cm) wide, and all pallets are 41.0 in. (104.2 cm) wide by 53.0 in. (134.6 cm) deep.

3. If you are moving the system across a raised floor, lay plywood on the raised floor to prevent floor tiles from popping up when you move the system.
4. Move the system as close to the installation site as possible.

System Documentation

[Table 1-2](#) lists the hardware documents for ftServer V 2404, V 4408, and V 6408 systems, and the tasks described in each document.

Table 1-2. ftServer V 2404, V 4408, and V 6408 System Documentation

Document	Task
<i>Stratus ftServer Systems: PCI Adapter Guide (R461)</i>	Install, configure, replace, or troubleshoot PCI adapters
<i>Stratus ftServer Systems: Peripherals Site Planning Guide (R582)</i>	Find information about optional equipment that you have ordered with your system that is needed to complete site preparation
<i>Stratus ftServer V 2404, V 4408, and V 6408 Systems: Site Planning Guide (R645)</i>	Prepare a site for installation of your ftServer system
<i>Stratus ftServer V 2404, V 4408, and V 6408 Systems: Operation and Maintenance Guide (R646)</i>	Start up, shut down, and operate your system Troubleshoot system hardware Remove and replace CRUs, including PCI adapters
<i>Read Me First: Moving ftServer V 2404, V 4408, and V 6408 Systems to the Installation Site (R662)</i>	Inspect and unpack ftServer system hardware

Safety Notices

 **WARNING** _____

Risk of explosion if battery is replaced by an incorrect type. Dispose of used batteries according to the instructions provided with the battery.

 **WARNING** _____

If you receive locking power cords with your system, do not substitute other power cords. Use of the locking power cords ensures proper grounding of the system.

 **WARNING** _____

The system uses two power cords to provide redundant sources of power. To fully remove power from a system, disconnect both power cords. To reduce the risk that electrical shock could injure a person or damage the system, exercise caution when working in the unit even when only one power cord is connected.

 **WARNING** _____

To prevent a cabinet from tipping over and injuring a person or damaging the system, start installing systems from the bottom of the cabinet upward.

 **WARNING** _____

If you replace the modem cable supplied by Stratus, use a cable with a gauge of at least 26 AWG to prevent fire.

 **WARNING** _____

To avoid fire, electric shock, and equipment breakdown, prevent water or foreign objects from getting into the equipment. Do not let water or foreign objects, such as pins or paper clips, enter the equipment.

**WARNING** _____

To prevent fire or current leakage, do not plug the power cord into a nonconforming outlet. Use a power outlet with appropriate voltage and power type, as specified in this guide.

**WARNING** _____

Do not install the equipment where you may need an extension cord. Use of an extension cord that does not meet the power specifications introduces a risk of overheating that could lead to a fire.

**WARNING** _____

Disconnect the power cords from the server or power source before you install or relocate the equipment. All voltage is removed only when the power cords are disconnected.

**WARNING** _____

Do not install or store the equipment in an unsuitable place. Install or store the equipment in a place that meets the requirements specified in this guide. Avoid the following conditions to avoid the risk of fire:

- Dust
- High humidity, such as a place near a boiler
- Direct sunlight
- Instability, such as places not stabilized against earthquakes



WARNING

Do not use or store this product in a corrosive environment.

Avoid using or storing this product in an environment which may contain corrosive gases. Such gases include, but are not limited to, sulfur dioxide, hydrogen sulfide, nitrogen dioxide, chlorine, ammonia or ozone.

Avoid installing this product in a dusty environment or one that may contain corrosive materials such as sodium chloride or sulfur.

Avoid installing this product in an environment which may contain excessive metal flakes or conductive particles in the air.

Such environments may cause corrosion or short circuits within this product, resulting in not only damage to this product, but also fire.

If there are any concerns regarding the environment at the planned site of installation or storage, please contact your CAC or your authorized Stratus service representative.



WARNING

When installing a system or CRU, always connect the power cord first, before adding communications cables. The power cord contains the protective earth connection; it should be connected first and disconnected last, to maintain a grounded chassis.

Before attempting to remove a CRU from the system chassis, make sure to power off the CRU, disconnect communications cables, and then disconnect the power cord.

Never connect a power cord to a CRU when it is not located within the system chassis.

**WARNING** _____

Do not disassemble, repair, or alter the server, except as described in the *Stratus ftServer V 2404, V 4408, and V 6408 Systems: Operation and Maintenance Guide* (R646). There is a risk of an electric shock or fire as well as equipment malfunction if you do not observe the instructions in the *Stratus ftServer V 2404, V 4408, and V 6408 Systems: Operation and Maintenance Guide* (R646).

**WARNING** _____

Do not place any object on top of the server. The object may fall off and cause injuries, damage to hardware, or a fire.

**WARNING** _____

Do not leave the DVD tray ejected. Dust may enter the equipment and cause it to malfunction. The ejected tray may also become a cause of injuries.

安全注意事項



WARNING

若錯誤更換電池類型，將產生爆炸風險。請按電池包裝說明，妥善丟棄已耗廢電池。



WARNING

系統採用兩條電源線，以提供冗餘電源。欲徹底清除系統電源，先拔下兩條電源線。為降低觸電所導致的人體傷害或系統損害，請小心操作機體，即使系統僅插入一條電源線。



WARNING

欲預防儲櫃翻倒，進而導致人體傷害或系統損害，請從儲櫃下方開始往上安裝系統。



WARNING

若您更換由Stratus供應的數據機纜線，請使用至少有26 AWG壓力的纜線，避免發生火災。



WARNING

避免火災、觸電、設備故障、液體或其他異物進入設備。不得讓液體或類似圖釘或迴紋針等異物進入設備。

**WARNING**

為避免火災或漏電，不得將電源線插入規格不符的的插座中。請使用本指南指定之電壓及電源類別的的插座。

**WARNING**

不得使用延長線安裝設備。使用與指定電源規格不符的延長線會產生設備過熱風險，進而可能導致火災。

**WARNING**

安裝或移動設備前，請從伺服器或電源拔下電源插頭。

只有在拔下電源線後，設備的所有電壓才會消除。

**WARNING**

不得在不適合場所安裝或存放設備。請按本指南指定且符合規格要求的場所安裝或存放設備。避免下列可能產生火災風險的地方：

- 灰塵較多

- 熱水器旁濕氣較重的地方

- 陽光直照的地方

- 不平穩位置，例如易受地震影響的地方

 **WARNING**

不得在腐蝕性環境中使用或存放產品。避免在含腐蝕性氣體的環境使用或存放本產品，其中包括但不限於：二氧化硫、硫化氫、氮、氫、氨或臭氧。

不得將本產品安裝在灰塵較多或含類似氯化鈉或硫磺等腐蝕性物質的地方。

不得將本產品安裝在空氣中含過量金屬碎片或傳導粒子的地方。

上述環境可能導致本產品腐蝕或短路，因而損壞產品，甚至引起火災。若對產品安裝或存放的場地環境規劃有任何疑問，請與CAC或授權Stratus服務代表聯絡。

 **WARNING**

不得在伺服器已連接電源的狀態下連接界面電纜。安裝或移除任何內建裝置，或從伺服器拔下或連接任何界面電纜前，確認已關閉伺服器的電源，並從伺服器或電插座拔下電纜線。即使伺服器電源已切斷，在仍連接電源的狀態下，碰觸內建裝置、電纜或連接器也可能產生觸電、或因短路而引起火災。

 **WARNING**

除 *Stratus ftServer V 2404*、*V 4408* 和 *V 6408* 系統：操作和維修指南 (R646) 之說明外，不得以任何方式拆卸、修理或改裝伺服器。若未遵循 *Stratus ftServer V 2404*、*V 4408* 和 *V 6408* 系統：操作和維修指南 (R646) 的說明指示，將可能產生觸電、火災以及設備故障的風險。

 **WARNING** _____

不得在伺服器上放置任何物件。物件可能會掉落而導致人體傷害、硬體損壞或火災。

 **WARNING** _____

DVD光碟機不得靜置於彈出位置。灰塵進入設備將導致功能異常。彈出的光盤也可能是導致設備損壞的來源。

Chapter 2

AC Power Planning

This chapter describes the AC power requirements of ftServer V 2404, V 4408, and V 6408 systems. It contains the following sections:

- [“AC Power Overview” on page 2-1](#)
- [“Redundant Power Sources” on page 2-1](#)
- [“AC Power and HVAC Worksheets” on page 2-2](#)
- [“Selecting a UPS Unit for ftServer Systems” on page 2-4](#)
- [“Power Cord Summary” on page 2-7](#)
- [“Main Cabinet Ground Cables” on page 2-8](#)

AC Power Overview

For fault tolerance, each ftServer system requires two separate and independent AC power sources. These power sources feed two UPS units. The UPS units feed power to power distribution units (PDUs) inside the main cabinet that, in turn, distribute power to the system's components.

You can use one of the UPS models that Stratus has qualified. See [“Selecting a UPS Unit for ftServer Systems” on page 2-6](#) for more information.

You must also provide AC power to the system PC console, RSN console server, and RSN modem (if present) located outside the main cabinet.

Redundant Power Sources

Each ftServer system requires two separate and independent AC power sources: an *A-side* power source and a *B-side* power source. Because either side must be capable of continuing to provide power if power to the other side is lost, each power source must provide uninterruptible AC power.

Each PDU receives power from its power source and distributes power to the components inside the cabinet.

The top PDU (or if mounted vertically the left PDU when viewed from the rear) in the cabinet receives power from the A-side power source and distributes power to the following components:

- The A-side CPU-I/O enclosure
- The A-side of the optional network I/O enclosure
- One side of each disk storage enclosure that is installed in the system cabinet
- The A-sides of the supported Ethernet and Fibre Channel (FC) switches

The bottom PDU in the cabinet receives power from the B-side power source and distributes power to the following components:

- The B-side CPU-I/O enclosure
- The B-side of the optional network I/O enclosure
- Tape drive enclosures, if present
- One side of each disk storage enclosure that is installed in the system cabinet
- The B-sides of the supported Ethernet and FC switches

AC Power and HVAC Worksheets

When planning for the system's electrical needs, consider the following:

- The AC power service required at the site
- The cooling required to service dissipated power
- Power cord lengths, plug types, and current rating

This section contains the following worksheets:

- [Table 2-1](#), a site planning worksheet for determining the number and types of AC outlets required at the site and the lengths of the power cords. See "[Power Cord Summary](#)" on [page 2-7](#) for more information about power cords.
- [Table 2-2](#), a worksheet for site AC power and HVAC requirements.

For each row in [Table 2-1](#):

- Fill in the **Quantity of Product Purchased** column.
- Multiply it by the supplied value in the **No. of AC Outlets Required** column.
- Write the result in the **Subtotal of AC Outlets** column.
- Determine the total number of AC outlets by adding the values in the **Subtotal of AC Outlets** column.

Table 2-1. Worksheet for Planning Site AC Outlets and Cord Lengths

Product Purchased	Quantity of Product	No. of AC Outlets Required	Subtotal of AC Outlets	Type of Plug	AC Cord Lengths
ftServer V 2404, V 4408, or V 6408	—	—	0 [†]	NEMA L6-20P or hardwired to UPS AC output terminals. See Table 2-5 .	15 ft. (4.5m)
UPS units (two for each ftServer system)		x 1 =		Hardwire to site AC power source.	Provided by customer.
Total AC connectors					

† All ftServer components plug into PDUs in the main cabinet. Each PDU receives power from a UPS unit.

In [Table 2-2](#), determine the watts of AC power required by the system and its BTU output. For each row:

- Fill in the **Quantity** value and multiply it by the supplied **Watts** value.
- Write the result in the **Watts Subtotal** column.
- Determine the total number of watts of AC power required by adding the values in the **Watts Subtotal** column.
- Multiply each entry in the **Watts Subtotal** column by 3.41 and enter the number of BTUs in the **BTUs/hr. Subtotal** column.
- Determine the total number of BTUs per hour by adding the values in the **BTUs/hr. Subtotal** column.

Table 2-2. Work Sheet for Site AC Power and HVAC Requirements

Product Purchased	Quantity	Watts	Watts Subtotal	Convert to BTUs	BTUs/hr. Subtotal
ftServer V 2404 systems		x 2300 [†] =		x 3.41 =	
ftServer V 4408 and V 6408 systems		x 4000 [‡] =		x 3.41 =	
AA-E97700 Internet console server		x 20 =		x 3.41 =	
AA-E96600 RSN console server		x 4.2 =		x 3.41 =	
RSN modem		x 22 =		x 3.41 =	
Optional network I/O enclosure (fully loaded)		x 750 =		x 3.41 =	
Optional AA-T53300 or AA-T53400 tape enclosure		x215 =			
Total BTUs/hr.					
Total watts					

† For maximum configuration ftServer V 2404 systems consisting of two CPU-I/O enclosures, two fully populated ftScalable Storage trays, and two Ethernet switches.

‡ For maximum configuration ftServer V 4408 and V 6408 systems consisting of two CPU-I/O enclosures, six fully populated ftScalable Storage trays, two Ethernet switches, and two FC switches.

Selecting a UPS Unit for ftServer Systems

Stratus does not sell or service UPS units. However, Stratus has qualified UPS models for use with ftServer V 2404, V 4408, and V 6408 systems.

Each 38U system cabinet uses two UPS units: one to supply power to the A-side power distribution system and one to supply power to the B-side. Stratus does not supply the UPS units. You must purchase them directly from the UPS vendor.

Use [Table 2-3](#) to select a qualified Chloride UPS model.

Table 2-3. Qualified Chloride UPS Models

Region or Country	ftServer System Configuration	UPS Quantity, Model Number, and Options	Power Output of One UPS (Watts)
North and South America	ftServer V 2404 system	Two LT081XAT-0H8SX	4760
	ftServer V 2404 system with network I/O enclosure	Two LT081XAT-0H8SX and two LPBP610-2 batteries (one for each UPS)	4760
	ftServer V 4408 or V 6408 system	Two LT081XAT-0H8SX and two LPBP610-2 batteries (one for each UPS)	4760
	ftServer V 4408 or V 6408 system with network I/O enclosure	Two LT081XAT-0H8SX and two LPBP610-2 batteries (one for each UPS)	4760
International	ftServer V 2404 system	Two LT081XIT-0E3KX	4760
	ftServer V 2404 system with network I/O enclosure	Two LT081XIT-0E3KX and two LPBP610-2 batteries (one for each UPS)	4760
	ftServer V 4408 or V 6408 system	Two LT081XIT-0E3KX and two LPBP610-2 batteries (one for each UPS)	4760
	ftServer V 4408 or V 6408 system with network I/O enclosure	Two LT081XIT-0E3KX and two LPBP610-2 batteries (one for each UPS)	4760
Japan	ftServer V 2404 system	Two LT081XJT-0E0SX	4760
	ftServer V 2404 system with network I/O enclosure	Two LT081XJT-0E0SX and two LPBP610-2 batteries (one for each UPS)	4760
	ftServer V 4408 or V 6408 system	Two LT081XJT-0E0SX and two LPBP610-2 batteries (one for each UPS)	4760
	ftServer V 4408 or V 6408 system with network I/O enclosure	Two LT081XJT-0E0SX and two LPBP610-2 batteries (one for each UPS)	4760

Use [Table 2-4](#) to select a qualified American Power Conversion Corporation (APC®) UPS model.

Table 2-4. Qualified APC UPS Models

Region or Country	ftServer System Configuration	UPS Quantity, Model Number, and Options	Power Output of One UPS (Watts)
North and South America	ftServer V 2404 system	Two SYH4K6RMT	2800
	ftServer V 2404 system with network I/O enclosure	Two SYH4K6RMT (each with one SYBT2 battery)	2800
	ftServer V 4408 or V 6408 system	Two SYA8K16RMP (each with SYPD7 backplate kit and one SYBT5 battery)	6400
	ftServer V 4408 or V 6408 system with network I/O enclosure	Two SYA8K16RMP (each with SYPD7 backplate kit and two SYBT5 batteries)	6400
International	ftServer V 2404 system	Two SYH4K6RMI	2800
	ftServer V 2404 system with network I/O enclosure	Two SYH4K6RMI (each with one SYBT2 battery)	2800
	ftServer V 4408 system	Two SYA8K16RMI (each with one SYBT5 battery).	5600
	ftServer V 6408 system	Two SYA8K16RMI (each with one SYBT5 battery).	5600
	ftServer V 4408 system with network I/O enclosure	Two SYA8K16RMI (each with two SYBT5 batteries).	5600
	ftServer V 6408 system with network I/O enclosure	Two SYA8K16RMI (each with two SYBT5 batteries).	5600
Japan	ftServer V 2404 system	Two SYH4K6RMJ	2800
	ftServer V 2404 system with network I/O enclosure	Two SYH4K6RMJ (each with one SYBT2FR battery)	2800
	ftServer V 4408 or V 6408 system	Two SYA8K16RMJ (each with SYPD7 backplate kit and one SYBT5FR battery)	5600
	ftServer V 4408 or V 6408 system with network I/O enclosure	Two SYA8K16RMJ (each with SYPD7 backplate kit and two SYBT5FR batteries)	5600

AC Power Connections to Qualified UPS Models

AC input power cords must be hardwired to the qualified UPS models. [Table 2-5](#) lists how the PDU AC input power cords connect to the qualified UPS models.



WARNING

A qualified electrician must supply and hardwire the UPS AC input cord, and if required an AC output cord, distribution panel, or conduit to each UPS unit in compliance with local and national electrical code.

Table 2-5. UPS to PDU AC Power Cords for Qualified UPS Models

UPS Model	UPS to PDU Power Cord
Chloride - LT081XAT-0H8SX	The A-side and B-side PDU AC input cords plug into L6-20R receptacles on the A-side and B-side UPS units respectively.
Chloride - LT081XIT-0E3KX	Use two B52700-45V power cords for the A-side and B-side PDU AC input cords. These cords plug into the IEC C19 receptacles on the A-side and B-side UPS units respectively.
Chloride - LT081XJT-0H0SX	The A-side and B-side PDU AC input cords plug into L6-20R receptacles on the A-side and B-side UPS units respectively.
APC - SYH4K6RMT and SYA8K16RMP	The A-side and B-side PDU AC input cords plug into L6-20R receptacles on the A-side and B-side UPS units respectively.
APC - SYH4K6RMI and SYA8K16RMI	Use two B52700-45V power cords for the A-side and B-side PDU AC input cords. These cords plug into the IEC C19 receptacles on the A-side and B-side UPS units respectively.
APC - SYH4K6RMJ and SYA8K16RMJ	The A-side and B-side PDU AC input cords plug into L6-20R receptacles on the A-side and B-side UPS units respectively.

Power Cord Summary

[Table 2-6](#) describes where you can find more information about PDU and UPS power cords.



WARNING

Place all power cords out of the way of foot traffic.

Table 2-6. Power Cords

Component	Power Cord
UPS (model qualified by Stratus)	220 VAC input - Customer supplied (hardwired to UPS AC input terminals)
	220 VAC output - See “AC Power Connections to Qualified UPS Models” on page 2-7
PDU	See “AAP87600V PDU Specifications” on page A-7.

Main Cabinet Ground Cables

[Table 2-7](#) provides information about the main cabinet ground cable.

Table 2-7. Main Cabinet Ground Cable

Component	Cable Description	Stratus PN	Length
Cabinet ground leakage cable	10AWG ground leakage cable with 1/4 in. (6.35 mm) and M8 ring lugs	AW002000	15 ft (4.6m)

Chapter 3

Space Planning and Component Location

This chapter describes the space and location requirements for an ftServer V 2404, V 4408, or V 6408 system and its external components. As you plan the site, make sure that you locate external components so that all cords and cables between them and the system can reach their connection points.

This chapter describes the requirements for the following connections:

- [“RSN Connections” on page 3-1](#)
- [“Fibre Channel Connections” on page 3-2](#)
- [“UPS Connections” on page 3-3](#)
- [“Component Location and Cabling Summary” on page 3-3](#)
- [“Room Requirements” on page 3-5](#)
- [“Creating a Floor Plan” on page 3-8](#)

RSN Connections

ftServer V Series modules require a connection to the Remote Service Network (RSN), which allows the CAC or your authorized Stratus service representative to remotely diagnose, troubleshoot, and resolve problems online. The connection to the RSN is implemented through an *RSN bridge module*, which is a module that is physically connected to an RSN internet console server or an RSN dialup console server. The RSN bridge module provides connectivity to the RSN for both itself and other modules in the same system.

Stratus provides and installs the RSN console server and related components.

The AA-E97700 RSN Internet console server requires OpenVOS Release 17.1.0 or later. It connects the module to the RSN over a secure Internet connection.

The AA-E96600 RSN dialup console server connects the module to the RSN over a phone line using a modem. In addition to the telephone line (which you must supply), the RSN modem and the RSN console server use serial (null-modem) and Ethernet

cables, which Stratus provides and installs. See [“Component Location and Cabling Summary” on page 3-3](#) for more information about RSN cable requirements.

For additional information, see the following manuals:

- *OpenVOS System Administration: Administering and Customizing a System* (R281) for information on processes, files, and commands required for RSN support.
- *Stratus ftServer V 2404, V 4408, and V 6408 Systems: Operation and Maintenance Guide* (R646) for detailed information on RSN console server and RSN modem connections.
- *OpenVOS System Administration: Configuring a System* (R287) for information on the `devices.tin` file entries that OpenVOS requires for an RSN connection through a modem.

Fibre Channel Connections

ftServer V 2404, V 4408, and V 6408 systems support connections to ftScalable Storage G2 RAID controller enclosures and to optional tape drives through optical FC host bus adapters (HBAs) in the CPU-I/O enclosures. Stratus installs and connects ftScalable Storage G2 systems and tape drives as follows:

- ftServer V 4408 and V 6408 systems connect to ftScalable Storage G2 RAID controller enclosures through a U581V 20-Port Fabric Switch.
- ftServer V 2404 systems connect to ftScalable Storage G2 RAID controller enclosures directly through U580V Dual-Port 8-Gb Fibre Channel PCI Adapters.
- V 2404 systems support a single tape drive. The tape drive is optional and connects directly to the U580V Dual-Port 8-Gb Fibre Channel PCI Adapters.
- ftServer V 4408 and V 6408 systems support single or dual tape drives. Tape drives are optional and connect to the ftServer systems using a designated port on the U581V fabric switch.

The U580V PCI adapters are dual-ported. For connections to ftScalable Storage G2 RAID controller enclosures, ports are teamed in pairs for fault tolerance. For connections to tape drives, ports are not paired. If the system supports a dual tape drive, you can connect one or two tape drives to the HBA in a single PCI slot.

For more information on FC connections, see the following manuals:

- *Stratus ftServer Systems: Peripherals Site Planning Guide* (R582) for information about the supported tape drives and PCI adapters.
- *ftScalable Storage G2: Getting Started Guide* (R651) for information about connecting to ftScalable Storage G2 systems.

- *Stratus ftServer Systems: PCI Adapter Guide (R461)* for information about the adapters Stratus supplies for your ftServer system.

UPS Connections

For management of UPS units, each UPS unit connects to a different U772 Ethernet switch. You must supply Ethernet cables to connect the management card of each UPS unit to its U772 Ethernet switch (two cables).

Stratus provides a PDU AC input cord for each UPS unit. See [“Component Location and Cabling Summary” on page 3-3](#) for more information.

Component Location and Cabling Summary

Although many of the cords and cables are provided by Stratus, you must provide certain cord and cables. [Table 3-1](#) summarizes the cords and cables you need to be aware of for site planning purposes and whether Stratus provides them or not.

Table 3-1. Cord and Cable Summary (Page 1 of 2)

Component	Cord or Cable Type	Source	Description
AA-E96600 RSN dialup console server (requires C720V modem)	Ethernet cable (1)	Provided by Stratus	RSN console to system - 20 ft. (6.10m)
	Serial cable (1)	Provided by Stratus	RSN console to system - 25 ft. (7.62m)
	Serial cable (1)	Provided by Stratus	RSN console to modem - 10 ft. (3.05m)
C720V modem	Telephone cord (1)	Customer supplied	Modem (RJ-11) to service jack - ensure that cord is long enough to reach telephone service jack. See “Telephone Lines” on page 4-1 for more information.
UPS (2)	AC power cord (2)	Provided by Stratus	UPS output to system PDU input - 15 ft. (4.57m)
	Ethernet (2)	Customer supplied	Ensure that cables are long enough to reach from UPS units to U772 Ethernet switches in system cabinet.

Table 3-1. Cord and Cable Summary (Page 2 of 2)

Component	Cord or Cable Type	Source	Description
PC Console	Ethernet cable (1)	Provided by Stratus (optionally customer supplied)	PC console to system Ethernet port - 6ft. (1.83m). Provide your own cable if a longer cable is required.
	Serial cable (1)	Provided by Stratus	PC console to system COM port - 25 ft. (7.62m)
Telephone	Telephone cord (1)	Customer supplied	Ensure that the cord is long enough to reach from the telephone service jack to the telephone near the PC console.
Optional available Ethernet ports (embedded or PCI adapter)	Ethernet cable (1 for each optional port used)	Customer supplied	Ensure that cables are long enough to reach from site Ethernet port, hub, or switch. Cable type varies depending upon the type of Ethernet adapter. See the <i>Stratus ftServer Systems: PCI Adapter Guide</i> (R461) for specific cable requirements.
Optional U760 Eight-Port Serial Synchronous PICMG 2.16 Adapter (in optional NIO enclosure)	RS-232C, RS-449, or V-35	Provided by Stratus	Optional NIO enclosure to network connection - 12ft. (3.65m)

The lengths of supplied cords and cables dictate the maximum distance between the ftServer V 2404, V 4408, or V 6408 system and its external components. [Table 3-2](#) summarizes these constraints.

Table 3-2. Location of V Series System Components (Page 1 of 2)

Component	Location of Component	External Component Location
AA-E96600 RSN dialup console server (requires C720V modem)	Free standing, located outside the system cabinet	Place within 9 feet of system (length of Ethernet cable minus vertical runs)
C720V modem	Free standing. Typically located near the system cabinet	Place close to the AA-E96600 console server

Table 3-2. Location of V Series System Components (Page 2 of 2)

Component	Location of Component	External Component Location
UPS (2)	Typically located outside the system cabinet	Place within 8 feet of system (length of PDU AC input cords minus vertical runs)
PC Console	Located outside the system cabinet on a table or other suitable surface	Place immediately next to system (length of Ethernet cable minus vertical runs)
Telephone	Typically located near PC Console	Typically place within 17 feet of system
Optional U760 Eight-Port Serial Synchronous PICMG 2.16 Adapter	Inside NIO enclosure rackmounted in system cabinet	Place network connection points within 4 feet of system (length of adapter hydra cables minus vertical runs)

Room Requirements

To ensure that the installation site provides a properly equipped, cooled, and sized environment, make sure that the site:

- Is a computer room
- Provides clearances for air circulation, opening cabinet doors, removing cabinet panels, and servicing the system from the front and rear.

Locate the front and rear of the system at least 2.5 feet (ft) (0.76 meters (m)) from walls and other obstructions.

- Maintains reasonable temperature and humidity levels and has a thermometer and humidistat to monitor room temperature and humidity.

See [Chapter 2, “AC Power Planning”](#) for detailed information about HVAC planning and [Appendix A, “System Specifications”](#) for detailed information about temperature and humidity requirements.

- Is as free of dust as possible of airborne contamination (particulate and gaseous).



CAUTION

Due to the mission-critical nature of Stratus servers, data centers housing the equipment should follow the guidelines of airborne contamination (particulate and gaseous) as outlined in the ASHRAE (TC) 9.9 documentation. Particulate matter to adhere to ISO 14644-1 Class 8. Gaseous contamination, such as sulfur

or chlorine-bearing gases to adhere to ANSI/ISA-71.04-1985 Severity level G1.

Dust buildup in the system can impede air circulation and heat transfer, causing components to become less reliable as the ambient temperature rises.

Fans clogged by dust fail to expel hot air, causing circuit boards to overheat and fail.

Dust on circuit boards raises the temperature, thus reducing the component's mean time between failure (MTBF).

Dust circulating in the room increases the risk of fire within the room by providing potential combustible material within the environment.

Dust contamination on tape devices causes mis-reads and -writes, leading to failure of attempts to back up and restore data.

- Has sufficient floor space for external components.
- Provides a table or desktop for external devices such as a telephone, RSN console server, RSN modem (if present), and a system PC console.

You **cannot** place these peripheral components in or on top of a system cabinet.

- Allows the system and peripheral devices to be placed within the room so that power cords and communications cables will reach their respective power receptacles, telephone jacks, and other connection points.
- Provides communications cable connectors or patch panels as needed.
- Provides two electrically separate grounded AC circuits to connect to the UPS units
- Provides grounded AC wall outlets for external components that do not connect to a PDU.
- Provides cutouts in the floor for routing cables, if the site has an elevated floor.
- Contains space for future expansion.



CAUTION

Do not place the system in an area of high electrostatic discharge. Static electricity may damage components. Do not locate components near transformers or other electromagnetic devices.

See [Appendix A, "System Specifications"](#) and *Stratus ftServer Systems: Peripherals Site Planning Guide (R582)* for the dimensions of system components.

Figure 3-1 illustrates the space-planning considerations. You must provide a flat surface for the RSN console server and the RSN modem (if present).

Figure 3-1. Space-Planning Considerations

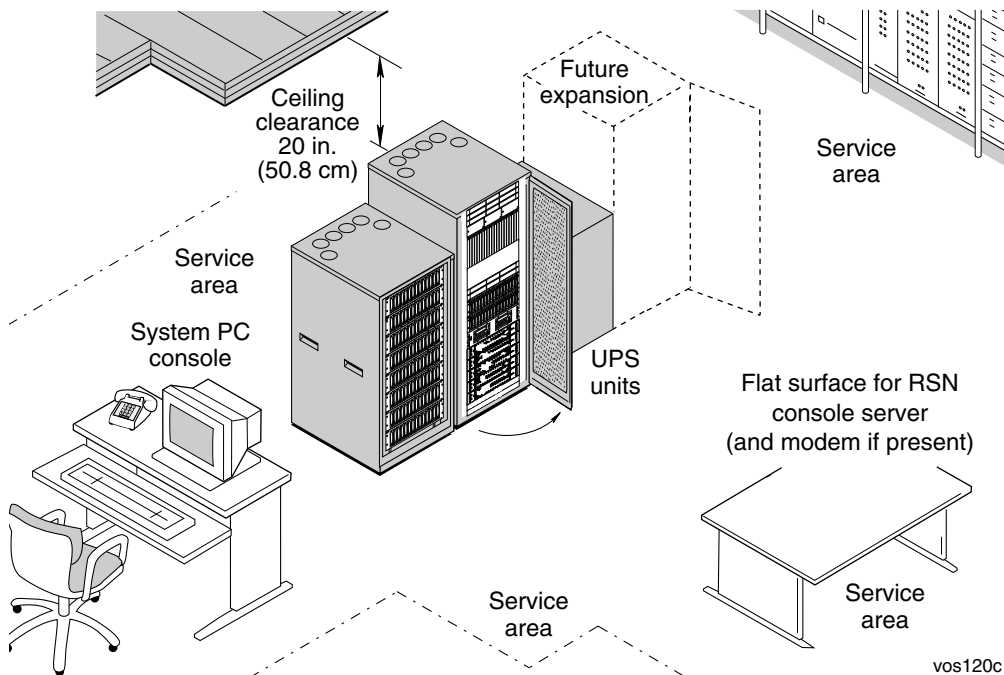

Cabinet Mounting and Leveling Considerations

The main cabinet has cabinet-leveling feet. Anti-tip brackets are optional. The cabinet-leveling feet and the anti-tip brackets rest on top of the floor, so you do not need to drill holes in the floor.

Creating a Floor Plan

This section provides equipment templates and a site-layout grid to help you plan the placement of the components within the room. [Appendix A, “System Specifications”](#) provides detailed specifications for each of the system’s components.

[Figure 1-1](#) and [Figure 1-2](#) illustrate a typical layout for the system cabinet, storage cabinet, UPS units, and system PC console. Additionally, [Figure 1-1](#) shows the RSN dialup console server and RSN modem and [Figure 1-2](#) shows the RSN Internet console server.

Use the equipment templates in [Figure 3-2](#) and the site-layout grid in [Figure 3-3](#) to create a floor plan of the installation site for your ftServer system. On this floor plan, sketch the:

- Locations of the system and all external components
- Locations and types of AC power outlets
- Lengths and routes of power cords
- Locations of phone jacks, Ethernet jacks, switches, and/or hubs
- Lengths and routes of telephone and other communications and interface cables

NOTE _____

Make sure that all cords and cables are long enough to reach between their respective components and connectors. Route all cables out of the way of foot traffic.

[Figure 3-2](#) contains the equipment templates to be used in the site-layout grid.

The site-layout grid in [Figure 3-3](#) represents a room measuring 20 ft. by 25 ft. (6 m by 8m). Note that the minimum room size for the core system components is 8 ft. by 8 ft. (2.6m by 2.6m). The scale of [Figure 3-3](#) is 1/4-inch (0.64 cm) equals 1 foot (30.5 cm).

In [Figure 3-3](#), trace the outline of the room in which the ftServer system will be located. Then, photocopy and cut out the templates in [Figure 3-2](#) and arrange them to represent your ftServer configuration in the outline of the room. The equipment templates are drawn to the same scale as the grid page.

Figure 3-2. System Equipment Templates

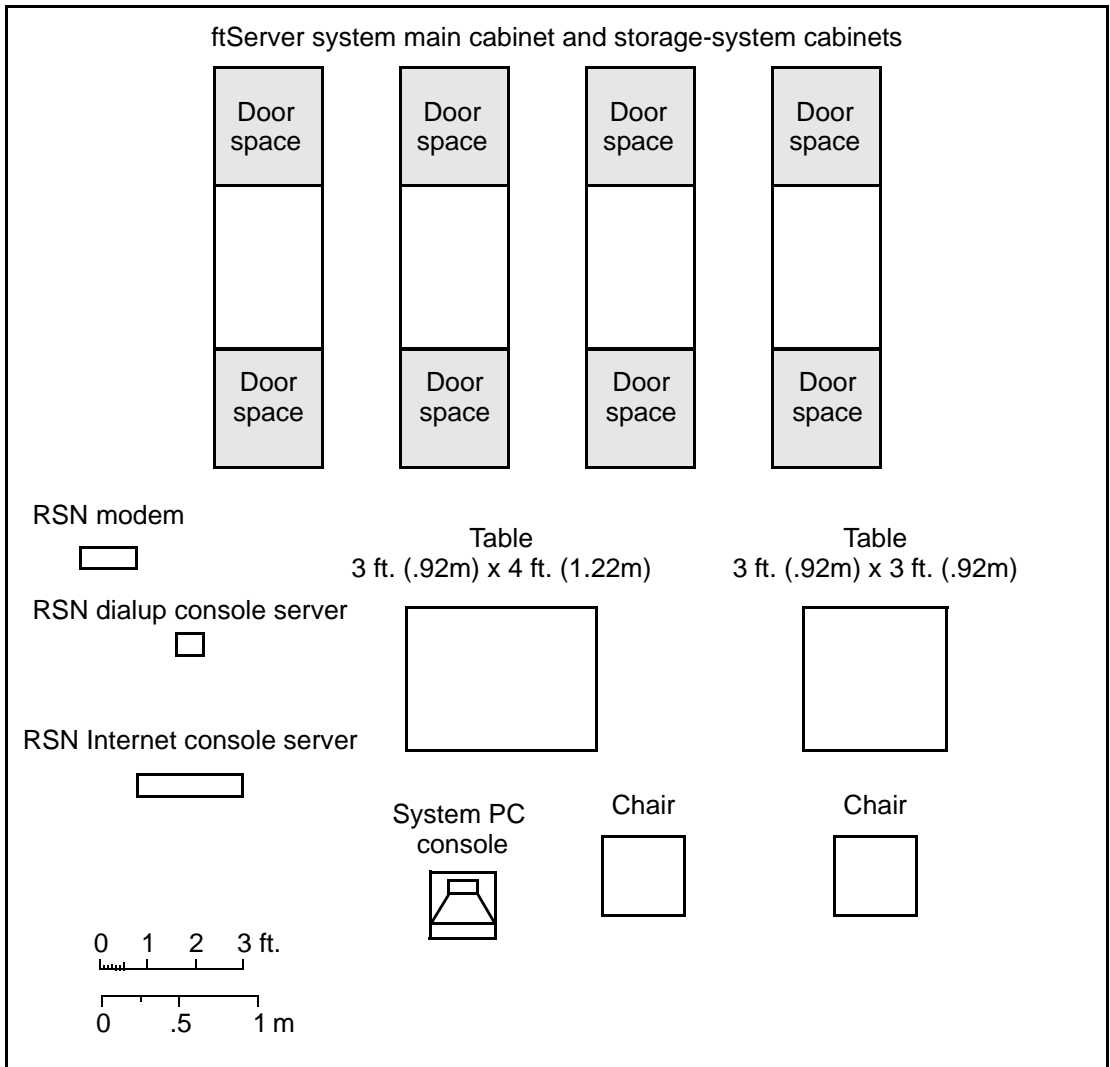

NOTE _____
 The shading on the templates indicates the access area required for servicing.

Figure 3-3. Site-Layout Grid

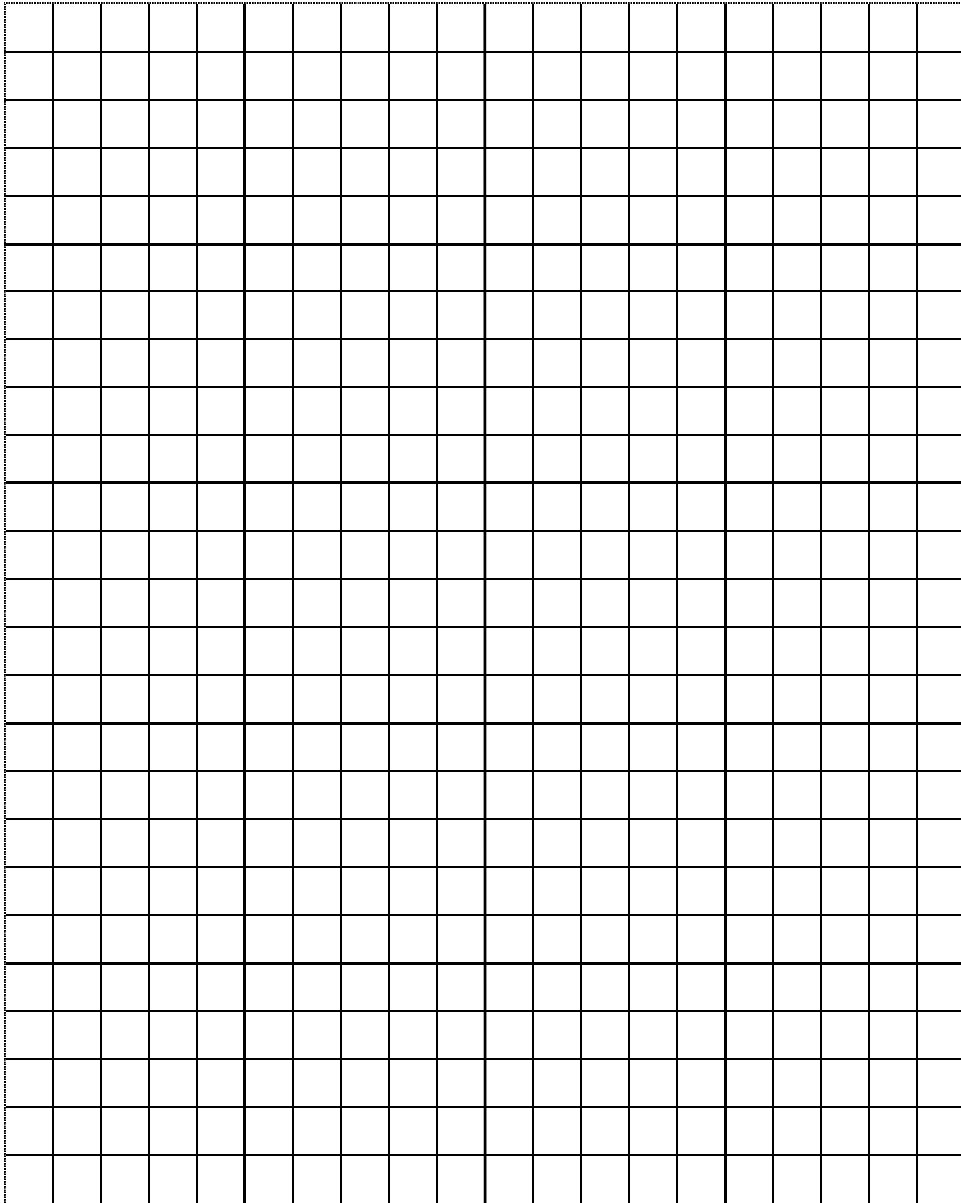

 = 1 square foot

Chapter 4

Other Infrastructure Requirements

This chapter describes other infrastructure requirements, including telephone, Ethernet networks, and the system PC console. It contains the following sections:

- “Telephone Lines” on page 4-1
- “Network Connections” on page 4-2
- “System PC Console” on page 4-4

Telephone Lines

You must provide one telephone and one or two telephone lines at your site:

- You must have one telephone and line that is reserved for making voice service calls. The telephone should be placed such that it can be used by a person who has access to the PC console, the front of the system, and the back of the system.
- If you are using the AA-E96600 RSN dialup console server you must supply an additional telephone line to connect to the RSN modem. You must supply a telephone cable of sufficient length which has an RJ-11 connector on the end which connects to the modem.

NOTE

To provide the most reliable service for RSN connections, use a dedicated phone line for the modem. RSN calls routed through a PBX might be slow, due to the load on the PBX, or might not complete successfully because the calls can become disconnected. If you must use a PBX, do not route the telephone extension through a switchboard; instead, provide a direct-dial analog number.

For additional information, see the following manuals:

- *OpenVOS System Administration: Administering and Customizing a System* (R281) for information on processes, files, and commands required for RSN support.

- *Stratus ftServer V 2404, V 4408, and V 6408 Systems: Operation and Maintenance Guide* (R646) for detailed information on modem connections.
- *OpenVOS System Administration: Configuring a System* (R287) for information on the `devices.tin` file entries that OpenVOS requires for an RSN connection through a modem.

Network Connections

The following sections provide site-planning information for networks:



WARNING

Make sure network cables can be routed out of the way of foot traffic.

- [“Site Ethernet Networks” on page 4-2](#)
- [“Ethernet Subnet Requirements” on page 4-3](#)
- [“Maintenance Network” on page 4-3](#)

Site Ethernet Networks

For connections to one or more optional Ethernet site networks, you must provide the following:

- site Ethernet ports, hubs, or switches
- Ethernet cables

You connect a site network to the ftServer system using any available Ethernet ports in the embedded adapters or in supported Ethernet PCI adapters. See [Table 1-1](#) for a list of supported adapters.

NOTE

Two Ethernet ports are typically paired and teamed in software for fault tolerance. Each member of the pair requires an Ethernet cable. For information on teaming the Ethernet ports in software, see the *OpenVOS STREAMS TCP/IP Administrator’s Guide* (R419).

ftServer V 2404, V 4408, and V 6408 systems also support separate class C Ethernet subnets for various system components, as described in [“Ethernet Subnet Requirements” on page 4-3](#).

Ethernet Subnet Requirements

ftServer V 2404, V 4408, and V 6408 systems require separate Class C Ethernet subnets. [Table 4-1](#) lists the subnet requirements for different system configurations.

Table 4-1. Ethernet Subnet Requirements

System Configuration	Separate Class C Ethernet Subnets
ftServer system with an optional network I/O enclosure	One subnet in the form 10.10.1.X to connect the host system to the maintenance network's U772 Ethernet switches. See "Maintenance Network" on page 4-3 for more information.
	A second subnet in the form 10.20.1.X to connect the host system and the network I/O enclosure.
	Additional subnets to connect the host system to site networks
ftServer system without an optional network I/O enclosure	One subnet in the form 10.10.1.X to connect the host system to the maintenance network's U772 Ethernet switches. See "Maintenance Network" on page 4-3 for more information.
	Additional subnets to connect the host system to site networks

Maintenance Network

The CAC or other authorized Stratus service representative uses a maintenance network for remote service and debugging of components in ftServer V 2404, V 4408, and V 6408 systems. The maintenance network connects the following components to two U772 24-Port 10/100 Ethernet Switches:

- ftScalable Storage G2 RAID controller modules
- U581V 20-Port Fabric Switch
- RSN console server
- UPS units
- system PC console

Stratus creates this network when installing the system and supplies the cables for it (except for the UPS Ethernet cables, which are customer supplied).

NOTES _____

1. The maintenance network is reserved for Stratus support and maintenance operations only. Do not connect other devices to it.

2. The U772 24-Port 10/100 Ethernet Switch is the only supported switch. You cannot use any other type of hub or switch in the maintenance network.

System PC Console

You must provide a PC with the following software and port to operate as the system PC console:

- The Microsoft® Windows® 7, Windows XP, or Windows Vista® operating system freshly installed
- A serial port or USB-to-serial port converter
- TinyTERM® terminal emulation software installed (Stratus provides this terminal emulation software)

Optionally, you can provide your own Ethernet cable if the provided six-foot long Ethernet cable is not long enough for your site (see [Table 3-1](#)).

See “[Component Location and Cabling Summary](#)” on [page 3-3](#) for information about PC console cable requirements. See the *OpenVOS System Administration: Configuring a System* (R287) manual for information about how to configure the emulation software on the system PC console.

Chapter 5

Supported Configurations

This chapter contains information about supported cabinet configurations.

Cabinet Configurations

Figures 5-1 through 5-3 show the supported ftServer system cabinet configurations. The illustrations show the locations of components and filler panels.

Figure 5-1 illustrates an ftServer V 4408 or V 6408 system without the optional ftScalable Storage expansion trays, tape-drive enclosure, and network I/O enclosure.

Figure 5-1. Base ftServer V 4408 or V 6408 System

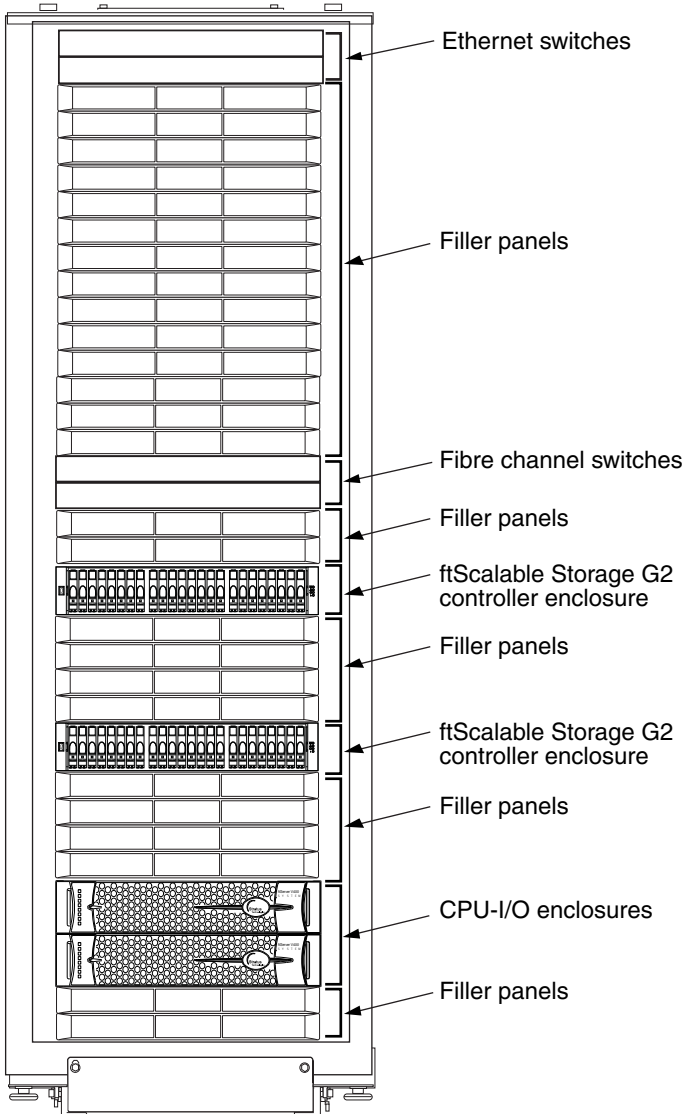

vos224a

Figure 5-2 illustrates a fully configured ftServer V 4408 or V 6408 system that includes the optional ftScalable Storage expansion trays, tape-drive enclosure, and network I/O enclosure.

Figure 5-2. Fully Configured ftServer V 4408 or V 6408 System

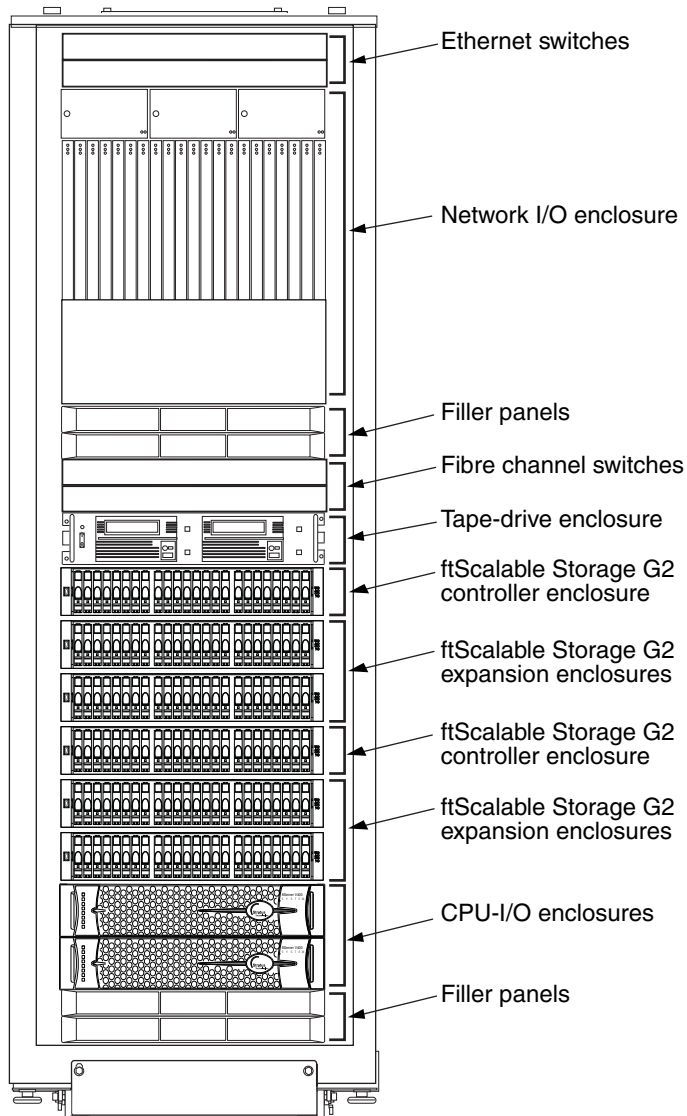

vos225a

Figure 5-3 illustrates an ftServer V 2404 system without the optional network I/O enclosure in a 24U cabinet. When the V 2404 is ordered with the network I/O enclosure, it is housed in a 38U cabinet. The V 2404 system does not support ftScalable Storage G2 expansion enclosures.

Figure 5-3. ftServer V 2404 System Without Network I/O Enclosure

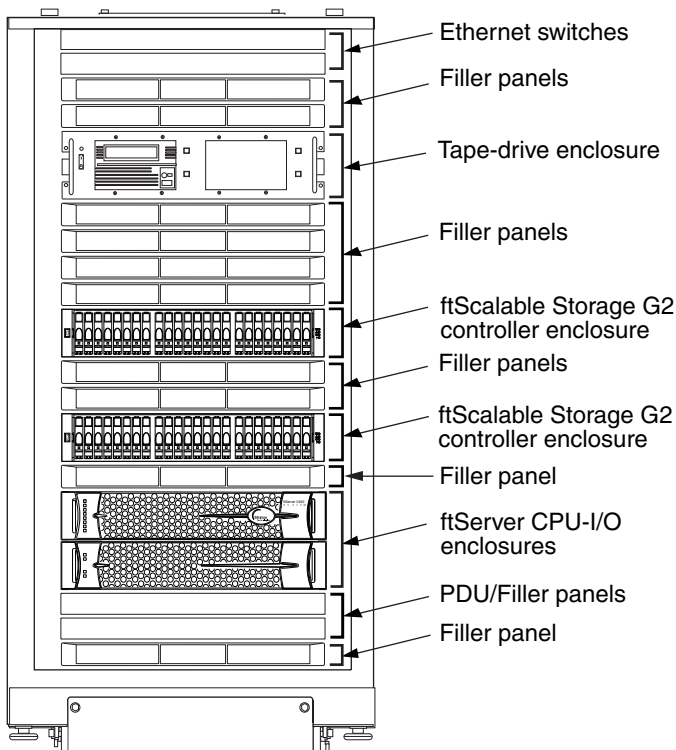

vos226a

Appendix A

System Specifications

For system specifications, see:

- [“System Specifications” on page A-1](#)
- [“AAP87600V PDU Specifications” on page A-7](#)

NOTES

1. The system temperature and humidity requirements defined in Tables [A-2](#) and [A-3](#) are the **minimum** requirements the site must provide.
2. The temperature and humidity requirements for optional components are provided in the *Stratus ftServer Systems: Peripherals Site Planning Guide (R582)*.

System Specifications

The following figures show front and rear views of the systems.

- [Figure A-1](#) shows the front of a CPU-I/O enclosure pair in an ftServer system cabinet, with its bezel pulled forward.
- [Figure A-2](#) shows the rear of a CPU-I/O enclosure pair in an ftServer system cabinet, specifying the locations of the connectors at the rear of the system.

[Table A-1](#) lists the dimensions of the system cabinets. [Table A-2](#) lists the specifications for the ftServer CPU-I/O enclosure and backplane assembly. The specifications in [Table A-2](#) do not include information about other components such as storage enclosures or tape drives. See the *Stratus ftServer Systems: Peripherals Site Planning Guide (R582)* for the specifications of these other components.

Figure A-1. CPU-I/O Enclosures: Front View

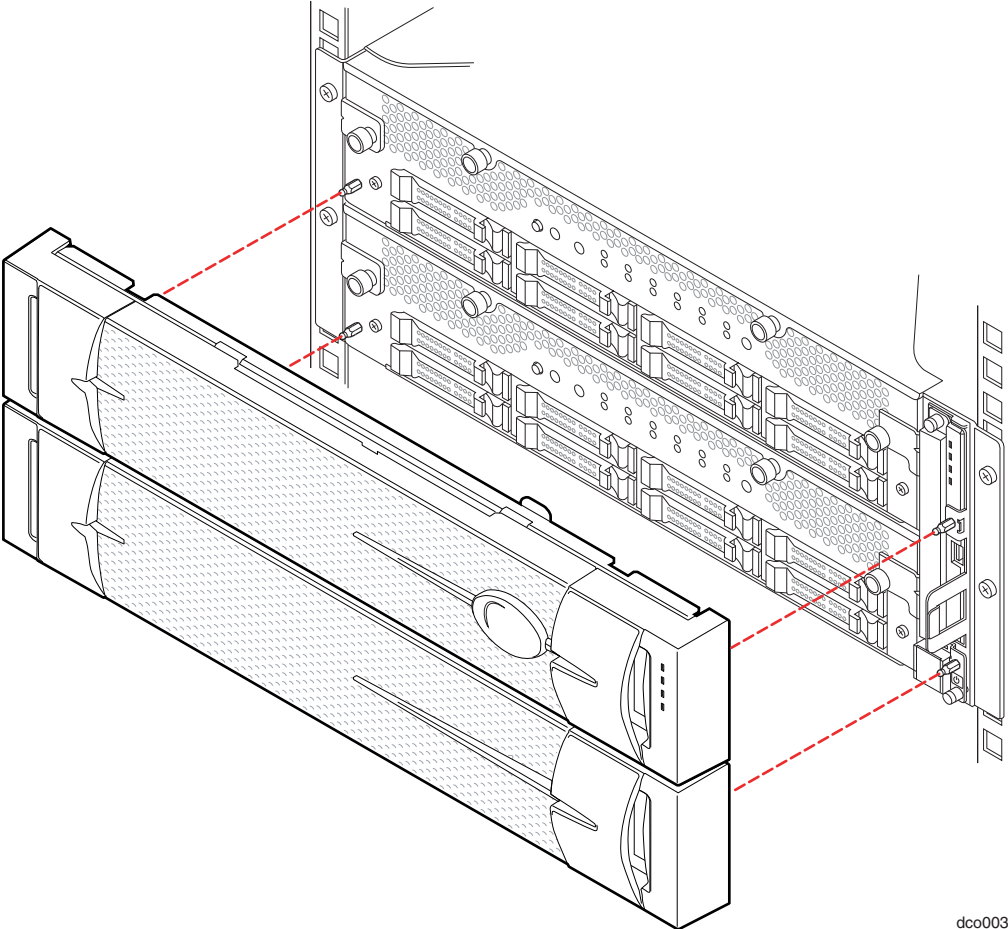

dco003a

Figure A-2. ftServer CPU-I/O Enclosures: Rear View

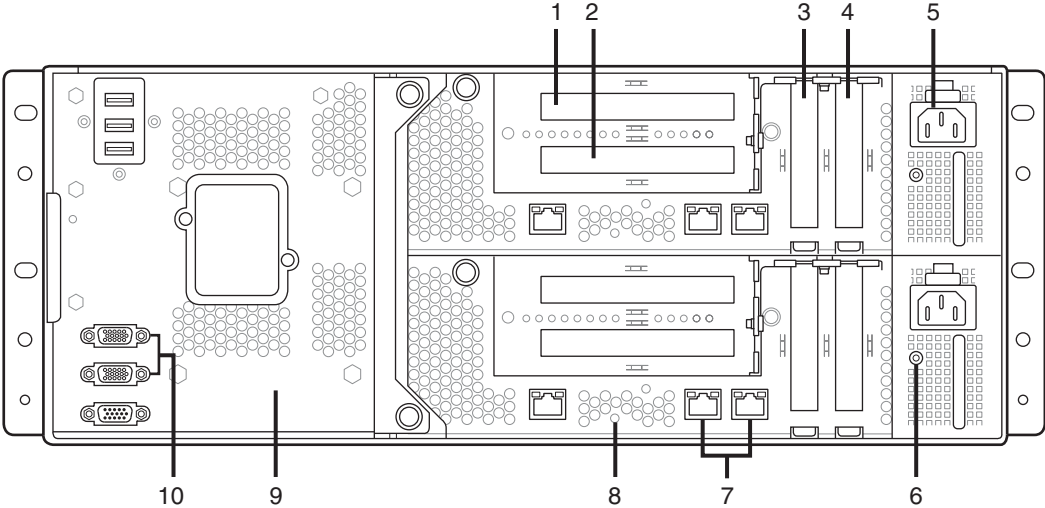

vdco004a

- | | | | |
|---|-------------------------|----|--|
| 1 | PCIe adapter slot 3 (2) | 6 | Power supply LED (2) |
| 2 | PCIe adapter slot 4 (2) | 7 | Embedded 10/100/1000-Mbps Ethernet ports (4) |
| 3 | PCIe adapter slot 1 (2) | 8 | System backplane |
| 4 | PCIe adapter slot 2 (2) | 9 | System backplane |
| 5 | Power receptacles (2) | 10 | Serial (COM) ports (2) |

Table A-1. Cabinet Dimensions

24U Shipping Container	
Height (including pallet)	56 in. (1.42m)
Width	41 in. (1.04m)
Depth	53 in. (1.35m)
38U Shipping Container	
Height (including pallet)	79.75 in. (2.03m)
Width	41 in. (1.04m)
Depth	53 in. (1.35m)
24U Cabinet	
Height (including casters)	50 in. (1.27m)
Width	27.5 in. (70 cm)
Depth	41 in. (1.04m)
Weight, empty	275 lb (125 kg)
Weight, empty with pallet and shipping container	436 lb (197.8 kg)
Weight capacity	1500 lb (559.9 kg)
38U Cabinet	
Height (including casters)	74 in. (1.9m)
Width	27.5 in. (70 cm)
Depth	41 in. (1.04m)
Weight, empty	344 lb (156 kg)
Weight, empty with pallet and shipping container	512 lb (232.2 kg)
Weight capacity	1500 lb (559.9 kg)

Table A-2. V 2404, V 4408, and V 6408 System CPU-I/O Enclosure: Specifications (Page 1 of 2)

Power	
Input power	700W for each enclosure (1400W total)
Nominal input voltage	200-240VAC; 50/60 Hz
Protective earth ground current	3.5 mA maximum for each AC power cord
Physical Dimensions	
Height	7.0 in. (17.78 cm; 4U)
Width	17.50 in. (44.45 cm)
Depth	29.27 in. (74.34 cm), excluding rails and bezel
Weight, including 12 DIMMS, 4 processors	Two enclosures, fully loaded: 84 lbs (38 kg) Rails and shelf unit: 13.8 lb (6.26 kg)
Environmental	
Operating temperature	41° F to 95° F (5° C to 35° C) For every 800 ft (243.8 m) above 2000 ft (609.6 m), lower the maximum operating temperature by 1°C.
Storage temperature	-38° F to 140° F (-40° C to 60° C), vented
Operating altitude	0 ft to 10,000 ft (0m to 3,048m)
Maximum rate of temperature change during operation	12° C per hour
Relative humidity during operation	20% to 80% (noncondensing)
Relative humidity during storage	20% to 80%
Heat dissipation, each system (both enclosures)	4777 BTUs per hour
Air cleanliness	Meets ISO 14644-1 class 8 standards

Table A-2. V 2404, V 4408, and V 6408 System CPU-I/O Enclosure: Specifications (Page 2 of 2)

Features	
Processors	<p>ftServer 2404: One Quad-Core Intel® Xeon® 2.0 GHz processor in each CPU-I/O enclosure</p> <p>ftServer 4408: Two Quad-Core Intel Xeon 2.0 GHz processors in each CPU-I/O enclosure</p> <p>ftServer 6408: Two Quad-Core Intel Xeon 2.93 GHz processors in each CPU-I/O enclosure</p>
Memory	Six physical, fully-buffered (FB) double-data-rate (DDR) inline memory module (DIMM) slots in each CPU-I/O enclosure
Ports	<p>Two 10/100/1000-Mbps Ethernet ports in each CPU-I/O enclosure</p> <p>Two AC power connectors and two serial ports</p>
PCI slots	<p>Two low-profile PCIe slots on the motherboard, 6.6 in (167.75 mm) maximum adapter length</p> <p>Optional PCIe riser with two full-height-capable slots:</p> <ul style="list-style-type: none"> • Top riser slot (PCI 3): 7.7 in. (195.94 mm) maximum adapter length • Lower riser slot (PCI 4): 6.6 in. (167.75 mm) maximum adapter length
DVD drive	DVD (+/-R Drive) in the front panel for installation of OpenVOS software.

AAP87600V PDU Specifications

The AAP87600V PDU, shown in [Figure A-3](#), supplies power to ftServer systems and optional rack-mountable components.

Figure A-3. AAP87600V PDU

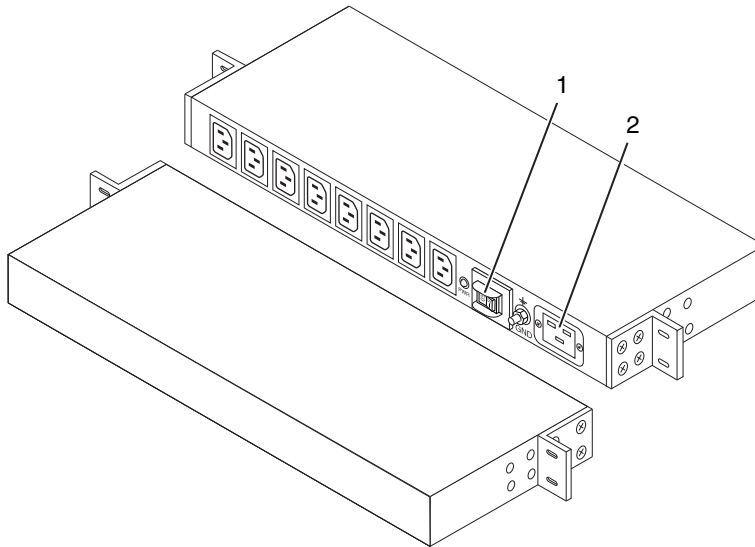

ssys108a

- 1 Power switch
- 2 Power receptacle

Table A-3 lists the specifications for the AAP87600V PDUs.

Table A-3. AAP87600V PDU: Specifications

Power	
Input power	N/A
Nominal input voltage; frequency	200–240 VAC; 50/60 Hz
Physical Dimensions	
Height	1.75 in. (4.45 cm)
Width	19.1 in. (48.51 cm)
Depth	6.75 in. (17.15 cm)
Environmental	
Operating temperature during operation	41° F to 95° F (5° C to 35° C) For every 800 ft (243.8m) above 2000 ft (609.6m), lower the maximum operating temperature (95° F (35° C)) by 1.8° F (1° C).
Maximum rate of temperature change during operation	12° C per hour or 0.2° C per minute
Relative humidity during operation	10% to 80% (noncondensing)
Storage temperature to 40,000 ft (12.2 km)	-38° F to 140° F (-40° C to 60° C)
Relative humidity during storage	5% to 95% (noncondensing)

Appendix B

Electrical Circuit and Wiring Information

For electrical circuit and wiring information that you need to provide to the contractor and/or facilities personnel responsible for wiring the power at the system installation site, see:

- [“Fault Protection Requirements” on page B-1](#)
- [“Grounding Considerations” on page B-1](#)
- [“Circuit Wiring Diagrams” on page B-2](#)
- [“Electrical Power Connectors” on page B-8](#)

Fault Protection Requirements

Each enclosure in ftServer systems contains internal fault/overload current protection. However, the system relies on the power distribution system at your site for protection against potential faults in the power cords and the wiring in the system base.

The pair of PDUs in the cabinet uses 20A or less circuit breakers in each power distribution branch that feeds the PDUs.

Grounding Considerations

The system obtains an earth reference ground through the power cords attached to the system. Similarly, each peripheral device connected to the system obtains ground through its power cord. For each peripheral device, you **must** ensure that a high-integrity safety-ground conductor is installed as part of the wiring system (in accordance with U.S. national electric code NFPA 70 or the equivalent). The international safety standard (EN60950) for electronic data processing (EDP) equipment also requires a ground conductor, but calls it a protective earth (PE) ground.

Depending upon local conditions, ground potentials may differ between the system base and any peripheral devices connected to the system base. All grounds in the system **must** return to the same reference point in the power distribution system, as close as possible to **zero (0) volt potential** relative to earth reference ground. Earth reference ground is typically a metal stake in the ground to which the ground conductors from one or more buildings are attached.

As shown in [Figure B-1](#), a *star ground* is often used to obtain the same earth reference ground. Each earth reference ground, such as the system base ground, is returned separately to a common point where a zero-volt (0V) earth ground exists. The star ground ensures that all equipment is at the same potential and that no noise or safety problems associated with an unpredictable or uncharacterized grounding system will occur.

Figure B-1. Star Ground Example

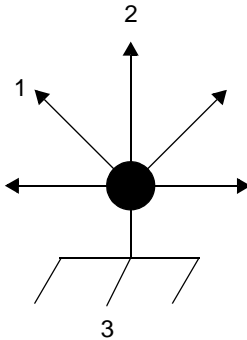

- 1 To monitor
- 2 To ftServer system
- 3 Earth reference ground (0V)

Circuit Wiring Diagrams

The following circuit wiring diagrams show how the hot, ground, and/or neutral AC signals should be connected to the power input plugs of the system and optional components:

- [Figure B-3](#) illustrates a single-phase 120V AC circuit connection.
- [Figure B-4](#) illustrates a single-phase 240V AC circuit connection.
- [Figure B-5](#) illustrates a split-phase 120/240V AC circuit connection.
- [Figure B-6](#) illustrates a three-phase 208V AC, Y-, or Δ -source circuit connection, phase-to-phase.
- [Figure B-7](#) illustrates a three-phase 380V AC, Y-, or Δ -source circuit connection, phase-to-neutral.

In the following diagrams, the power inputs for ftServer V 2404, V 4408, and V 6408 systems are labeled X and Y, as shown in [Figure B-2](#), to eliminate any ambiguities in the nomenclature. For single-phase applications, the X input is connected to the L

(Line) *hot* input, and the Y input is connected to the N (Neutral) input. However, for split-phase or three-phase applications, the X and Y inputs are connected to L1, L2, or L3 (separate lines). Therefore, for split-phase or three-phase applications, both X and Y can be electrically hot with respect to the system base (earth reference ground). [Figure B-2](#) shows the physical locations of the X and Y inputs on the system PDU.

Figure B-2. Power Input Labeling

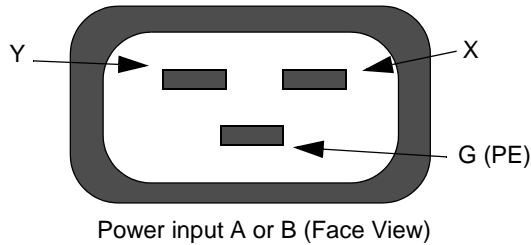

[Figure B-3](#) shows a single-phase 120V AC circuit connection. Note that this application requires a single-pole circuit breaker.

Figure B-3. Single-Phase 120V AC Circuit Connection

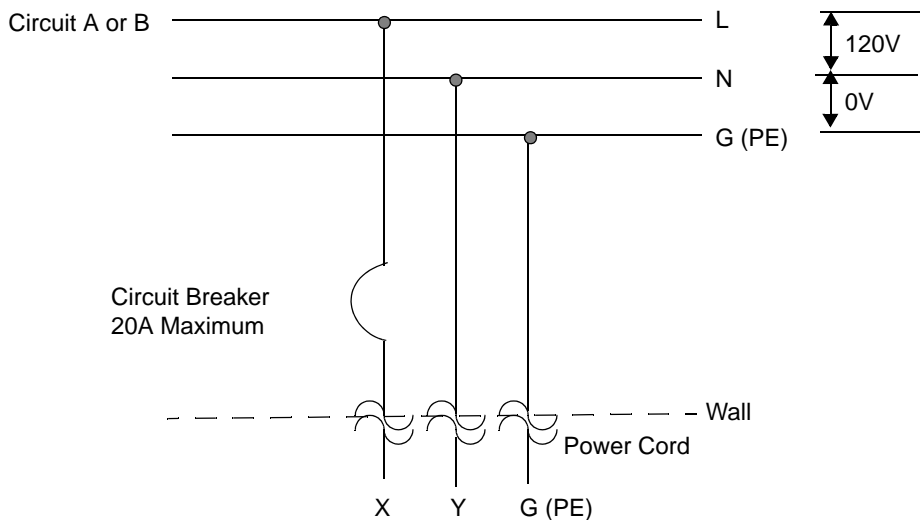

Figure B-4 shows a single-phase 240V AC circuit connection. Note that this application requires a single-pole circuit breaker.

Figure B-4. Single-Phase 240V AC Circuit Connection

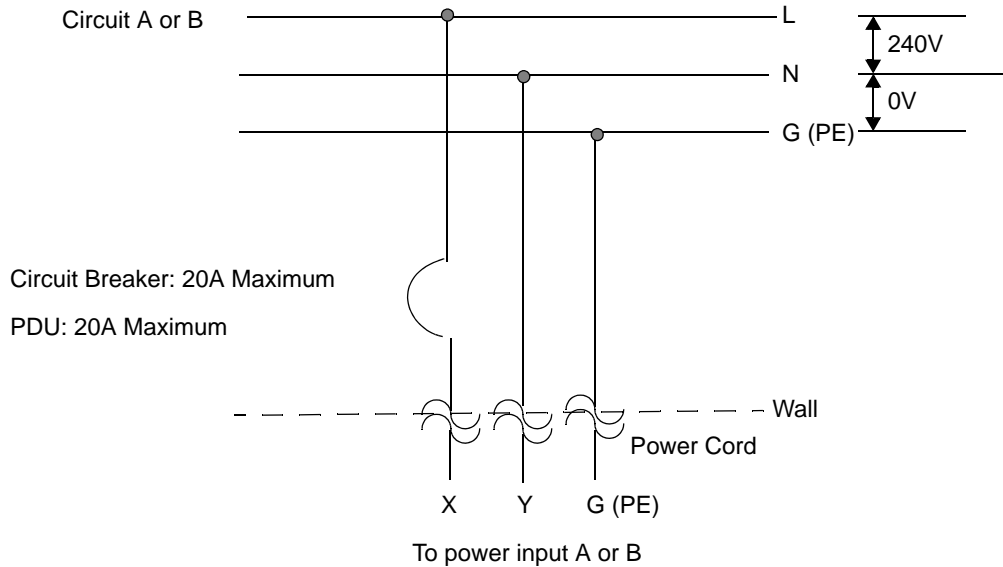

Figure B-5 shows a split-phase 120/240V AC circuit connection. Note that this application requires a double-pole circuit breaker.

Figure B-5. Split-Phase 120/240 Volts AC Circuit Connection

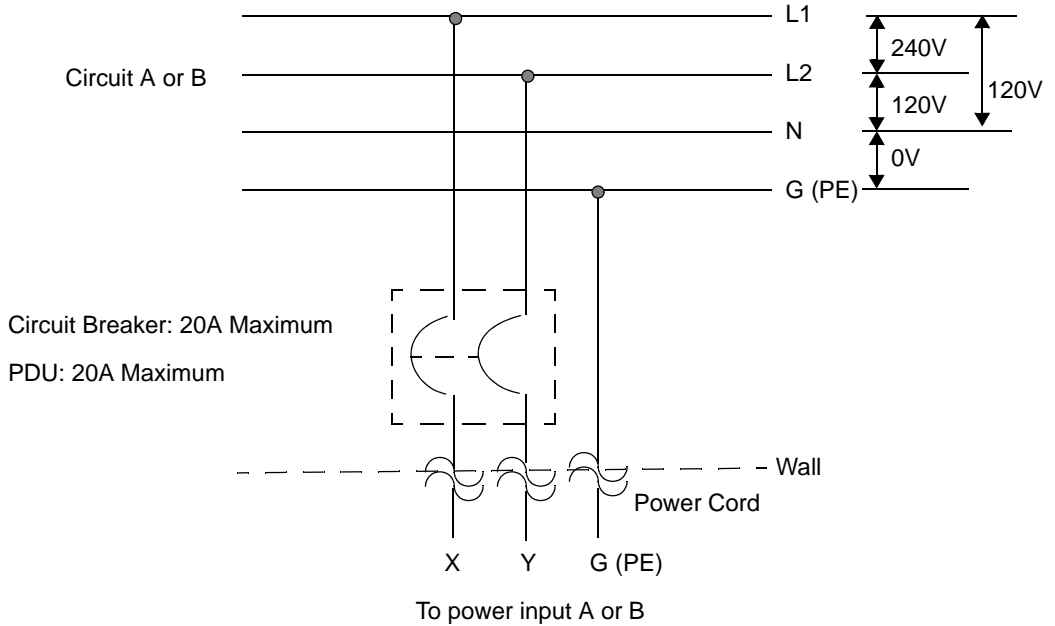

Figure B-6 shows a three-phase 208V AC, Y-, or Δ-source circuit connection, which is a phase-to-phase source connection. Note that the X and Y inputs on the system can be connected from L1 and L2, L2 and L3, or L1 and L3. This application requires a double-pole circuit breaker.

Figure B-6. Three-Phase 208V AC, Y-, or D-Source Circuit Connection, Phase-to-Phase

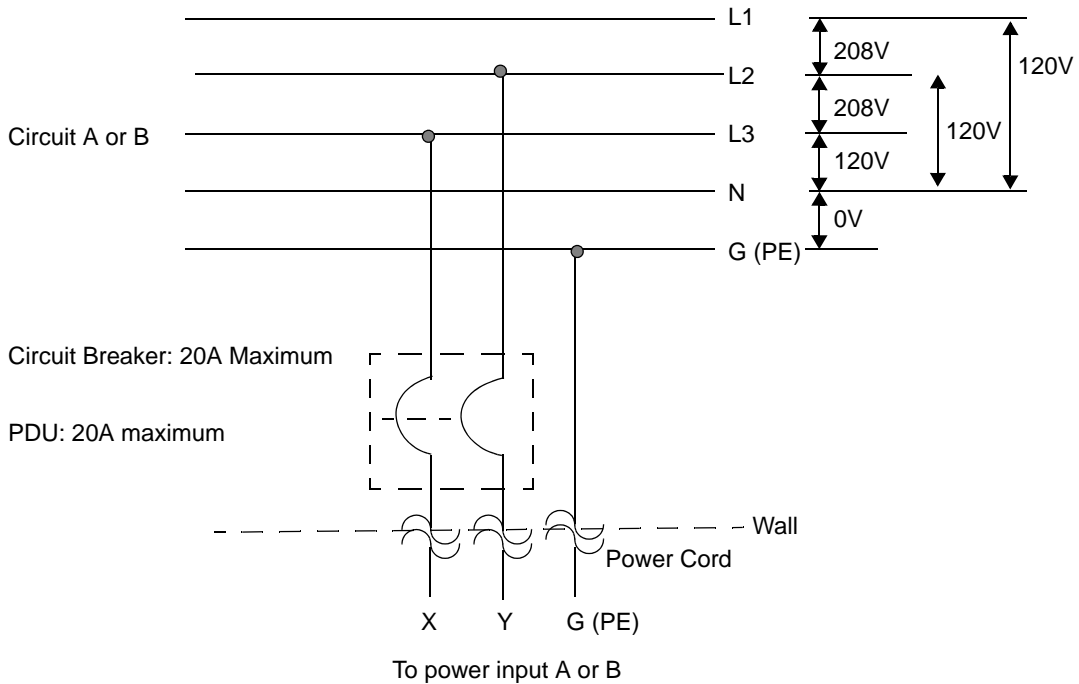
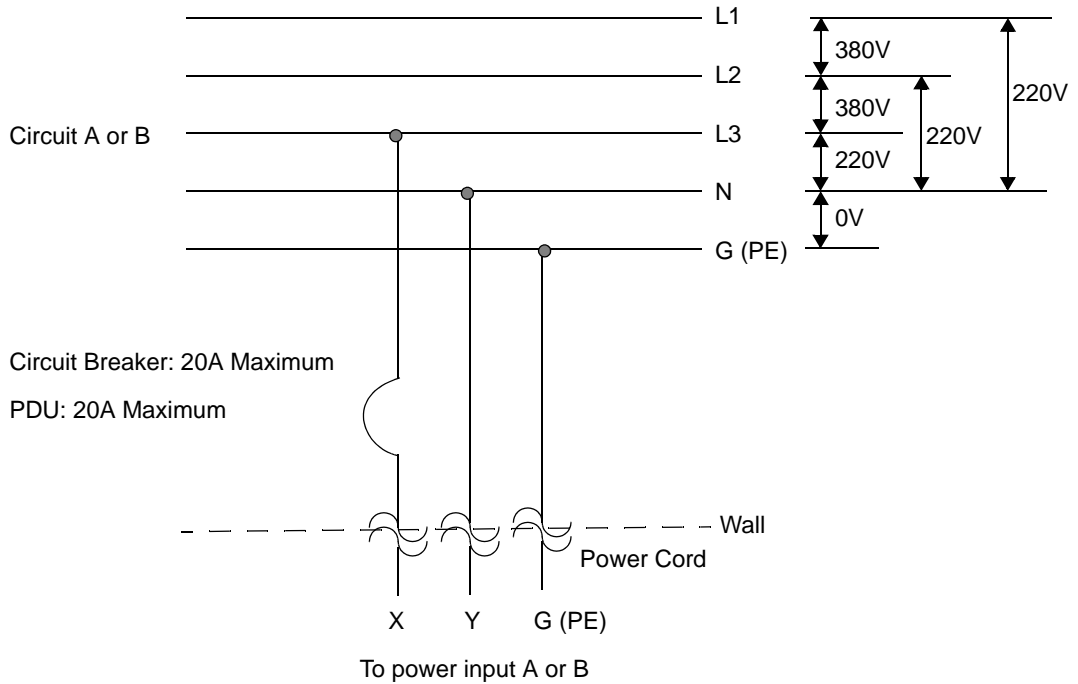

Figure B-7 shows a three-phase 380V AC, Y-, or Δ -source circuit connection, which is a phase-to-neutral source connection. Note that the system's X input can be connected to L1, L2, or L3. This application requires a single-pole circuit breaker.

Figure B-7. Three-Phase 380V AC, Y-, or Δ -Source Circuit Connection, Phase-to-Neutral



Electrical Power Connectors

Table B-1 describes the connectors required by the AC power cords that Stratus supplies with ftServer systems.

Table B-1. Connectors for AC Power Outlets

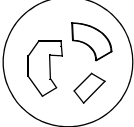
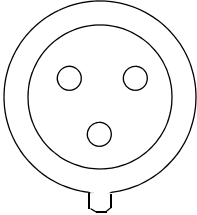
Connector	Configuration	Rating	Description
NEMA L6-20	 A circular symbol containing three stylized shapes representing the L-shaped pins of a NEMA L6-20 connector: two L-shaped pins on the left and one rectangular pin on the right.	20A, 250 volts AC	2-pole, 3-wire
IEC 60309 (formerly IEC 309)	 A circular symbol representing an IEC 60309 connector, showing three circular contact points arranged in a triangle (two on top, one on the bottom) and a small rectangular grounding pin at the bottom center.	16-20A, 250 volts AC	2-pole, 3-wire

Appendix C

Standards Compliance

For compliance information, see the following:

- [“Electronic Interference, Immunity, Safety, and Noise Level Standards Compliance” on page C-1](#)
- [“Toxic and Hazardous Substances and Elements Disclosure” on page C-6](#)

Electronic Interference, Immunity, Safety, and Noise Level Standards Compliance

All ftServer systems comply with the electromagnetic interference (EMI), immunity, safety, and noise regulations listed in [Table C-1](#). All necessary agency labels are on the system.

NOTES _____

1. This system must be configured with the components listed and described in the product configuration specifications. Deviations from this list of components will void agency certification.
2. You must install all wiring, including power and communications cables, in compliance with local and national electrical code (in the United States, national electrical code NFPA 70). In addition, you must use shielded communications cables to remain in compliance with Federal Communications Commission (FCC) and other international Electromagnetic compatibility (EMC) regulations.
3. All EMC emissions compliance tests are performed at a third-party certified test laboratory.

This equipment has been tested and found to comply with the limits for a Class A digital device, pursuant to part 15 of the FCC Rules. These limits are designed to provide reasonable protection against harmful interference when the equipment is operated in a commercial environment. This equipment generates, uses, and can radiate radio frequency energy and, if not installed and used in accordance with the instruction

manual, may cause harmful interference to radio communications. Operation of this equipment in a residential area is likely to cause harmful interference, in which case the user will be required to correct the interference at his own expense.



WARNING

Changes or modification to the product could void the user's authority to operate the equipment.

Table C-1. Compliance Standards for ftServer V 2404, V 4408, and V 6408 Systems (Class A)

Standard	Title	Country
EN 55022, Class A	Limits and methods of measurement of radio interference characteristics of Information Technology Equipment	European Union
EN 55024, Class A	Information Technology Equipment - Immunity characteristics - Limits and methods of measurement	European Union
EN 61000-3-2, Class A	Electromagnetic compatibility (EMC) – Part 3-2: Limits – Limits for harmonic current emissions (equipment input current <= 16 A per phase)	European Union
EN 61000-3-3, Class A	Electromagnetic compatibility (EMC) – Part 3-3: Limits – Limits of voltage changes, voltage fluctuations and flicker in public low-voltage supply systems (equipment input current <= 16 A per phase)	European Union
EN 60950-1	Safety of Information Technology Equipment	European Union
CB SCHEME IEC 60950-1	Safety of Information Technology Equipment	International
UL 60950-1, CSA C22.2 No. 60950-1-03	Safety of Information Technology Equipment	Certified to US and Canada standards
CISP22, Class A	Information Technology Equipment: Radio disturbance characteristics	International
FCC CFR47, Part 15, Class A	Code of Federal Regulations, Radio Frequency Devices	North America
AS/NZS CISPR 22, Class A	Information Technology Equipment - Radio Disturbance Characteristics - Limits and Methods of Measurement	Australia and New Zealand

Table C-1. Compliance Standards for ftServer V 2404, V 4408, and V 6408 Systems (Class A) (Continued)

Standard	Title	Country
ICES-003, Class A	Electronic Emissions from Data Processing Equipment and Electronic Office Machines	Canada
NOM-0190SCFI-1998	Data processing equipment safety	Mexico
GOST R	Safety of Information Technology Equipment, Electronic Emissions and Immunity	Russia
CISPR 22, Class A	Certificate of Compliance with the Radio Regulations	South Africa
KC, Class A	Technical Requirements for EMI Safety for ITE	South Korea
CCC, Class A	CCC Qualification (EMC/Safety)	China
VCCI V-3, Class A	Voluntary Control Council for Interference by Information Technology Equipment	Japan
BSMI, Class A	Information technology equipment - Radio disturbance characteristics	Taiwan

VCCI Note

この装置は、情報処理装置等電波障害自主規制協議会（VCCI）の基準に基づくクラスA情報技術装置です。この装置を家庭環境で使用すると電波妨害を引き起こすことがあります。この場合には使用者が適切な対策を講ずるよう要求されることがあります。

BSMI Note

警告使用者
這是甲類的資訊產品、在居住的環境中使用時、可能會造成射頻干擾、在這種情況下、使用者會被要求採取某些適當適對策

Energy Star Note

As defined by the EPA ENERGYSTAR Program Requirements for Computer Servers, Tier 1 requirements, this server is defined as a “Fully Fault Tolerant Server.” Presently there are no defined requirements, and this category of servers is ineligible to receive an Energy Star rating. As such there are no sales restrictions for local or federal agencies.

Korean User Information

사용자안내문

(User Information)

기종별	사용자안내문
A 급 기기 (업무용 방송통신기자재)	이 기기는 업무용(A 급) 전자파적합기기로서 판매자 또는 사용자는 이 점을 주의하시기 바라며, 가정외의 지역에서 사용하는 것을 목적으로 합니다.

Class A Equipments (Broadcasting and communication equipments for office work)

Seller and user shall be noticed that this equipment is suitable for electromagnetic equipments
for office work (Class A) and it can be used outside home.

Toxic and Hazardous Substances and Elements Disclosure

ftServer V 2404, V 4408, and V 6408 systems are compliant with the European Union's Restriction of Hazardous Substances Directive (RoHS) based upon the exception for lead used in servers.



WARNING _____

**The lithium battery contains perchlorate material.
Special handling may apply. See
www.dtsc.ca.gov/hazardouswaste/perchlorate.**

Index

A

AC power, 2-1
 cords
 specifications, 2-7
 UPS, 2-7
 requirements, 2-3
 source, 2-1
 worksheet, 2-2
American Power Conversion (APC) UPS. *See* APC UPS
anti-tip brackets, 3-7
APC UPS, qualified models, 2-6
A-side power source, 2-1

B

B-side power source, 2-1

C

cabinets, specifications, A-4
cables
 ground, 2-8
 planning for, 1-3, 3-1
CAC, getting assistance, 1-2
checklist for site planning, 1-2
Chloride Power Protection (CPP). *See* CPP UPS
circuit, electrical
 planning information, B-1
 wiring diagrams, B-2
communications cables
 planning for, 3-1
compliance, standards, C-1
connectors, electrical, B-8
console. *See* RSN console server *or* system PC console
cooling requirements, 2-2, 2-3
CPP UPS, 2-4
 qualified models, 2-5
Customer Assistance Center. *See* CAC

D

dust contamination, 3-6

E

earth reference ground, B-1
electrical connectors, B-8
electrical grounding, B-1
electrical wiring, B-1
environmental requirements
 maximum rate of temperature change, A-5
 operating humidity, A-5
 storage humidity, A-5
Ethernet subnet requirements, 4-3

F

fault-tolerant systems, site planning, 1-2
floor plan, 3-8
ftScalable Storage systems
 Fibre Channel connections, 3-2
ftServer systems
 moving to the installation site, 1-8
 preparing to install, 1-7
 supported configurations, 5-1
 taking delivery, 1-8

G

ground leakage cables, 2-8
grounding the system, B-1

H

hubs, network, 1-3
HVAC worksheet, 2-2

I

IEC 60309 connector, B-8
installation site
 floor plan, 3-8

- layout
 - sample grid, 3-8
 - templates, 3-8
- moving system to, 1-8
- preparation, 1-8

J

- jacks, Ethernet, 1-3

L

- leveling feet, 3-7

M

- main cabinet
 - anti-tip brackets, 3-7
 - leveling feet, 3-7

N

- NEMA L6-20 connector, B-8

P

- PDUs, 2-2
 - AAP87600
 - site planning, A-7
 - specifications, A-8
 - specifications, A-8
- power requirements, 2-3
- protective earth ground, B-1

R

- rack-mounted systems, A-1, A-5
- removing power, 1-10
- room requirements, 3-5
- RSN connection, 1-3, 3-1
 - cables, 3-1
 - RSN console server, 1-3, 3-1
 - RSN modem, 1-3

S

- safety, notices, 1-10
- single-phase circuit connections
 - 120 V AC, B-3
 - 240 V AC, B-4

- site planning
 - checklist, 1-2
 - overview, 1-1
- space planning
 - cables, 1-3
 - future expansion, 3-6
 - room requirements, 3-5
- specifications
 - AC power cords, 2-7
 - AP87600 PDUs, A-8
 - cabinet, A-4
 - CPU-I/O enclosure, A-5
- split-phase circuit connections
 - 120–240 V AC, B-5
- standards compliance, C-1
- star ground, B-2
- Stratus Customer Assistance Center. *See* CAC
- supported configurations
 - ftServer systems, 5-1
- switches, site network, 1-3
- system PC console, 1-2
 - requirements, 4-4

T

- technical support. *See* CAC
- telephone lines
 - for support calls, 1-5, 4-1
- terminal emulator, 4-4
- three-phase circuit connections
 - 208 V AC, B-6
 - 380 V AC, B-7

U

- U772 Ethernet switch, 4-3
- uninterruptible power supply (UPS). *See* UPS
- UPS, 2-4
 - AC power cords, 2-7
 - APC qualified models, 2-6
 - CPP qualified models, 2-5

W

- wiring, electrical, B-1
- worksheets
 - AC power, 2-2
 - HVAC, 2-2