

Stratus[®] ftServer[®] 2600, 4500, and 63x0 Systems: Site Planning Guide

Stratus Technologies
R655-02

Notice

The information contained in this document is subject to change without notice.

UNLESS EXPRESSLY SET FORTH IN A WRITTEN AGREEMENT SIGNED BY AN AUTHORIZED REPRESENTATIVE OF STRATUS TECHNOLOGIES, STRATUS MAKES NO WARRANTY OR REPRESENTATION OF ANY KIND WITH RESPECT TO THE INFORMATION CONTAINED HEREIN, INCLUDING WARRANTY OF MERCHANTABILITY AND FITNESS FOR A PURPOSE. Stratus Technologies assumes no responsibility or obligation of any kind for any errors contained herein or in connection with the furnishing, performance, or use of this document.

Software described in Stratus documents (a) is the property of Stratus Technologies Bermuda, Ltd. or the third party, (b) is furnished only under license, and (c) may be copied or used only as expressly permitted under the terms of the license.

Stratus documentation describes all supported features of the user interfaces and the application programming interfaces (API) developed by Stratus. Any undocumented features of these interfaces are intended solely for use by Stratus personnel and are subject to change without warning.

This document is protected by copyright. All rights are reserved. Stratus Technologies grants you limited permission to download and print a reasonable number of copies of this document (or any portions thereof), without charge, for your internal use only, provided you retain all copyright notices and other restrictive legends and/or notices appearing in the copied document.

The Stratus Technologies logo, the Stratus 24 x 7 logo, ActiveService, ftScalable, and Active Upgrade are trademarks of Stratus Technologies Bermuda, Ltd.

The registered trademark Linux is used pursuant to a sublicense from the Linux Mark Institute, the exclusive licensee of Linus Torvalds, owner of the mark on a world-wide basis. FLEXlm is a registered trademark of Macrovision Corporation. VMware, vSphere, ESX, and vMotion are registered trademarks or trademarks of VMware, Inc. in the United States and/or other jurisdictions. QLogic, the QLogic logo SANbox, InfiniPath and SANblade are trademarks or registered trademarks of QLogic Corporation.

All other trademarks are the property of their respective owners.

Manual Name: *Stratus ftServer 2600, 4500, and 63x0 Systems: Site Planning Guide*

Part Number: R655

Revision Number: 02

Software Release Number: ftServer System Software for the Windows Operating System, Release 7.0.0

ftServer System Software for the Linux Operating System, Release 7.1.5

ftServer System Software for VMware vSphere, Release 3.1.2

Publication Date: March 2011

Stratus Technologies, Inc.

111 Powdermill Road

Maynard, Massachusetts 01754-3409

© 2011 Stratus Technologies Bermuda, Ltd. All rights reserved.

Contents

Preface	ix
----------------	----

1. Site Planning for ftServer 2600, 4500, 6300, and 6310 Systems	1-1
Site Planning Overview	1-1
The Stratus ActiveService Network	1-2
Site Planning Checklist	1-3
System Documentation	1-7
Safety Notices	1-10

2. Electrical Power Planning	2-1
Redundant Power Sources	2-1
AC Power and HVAC Service Requirements	2-2
AC Power Outlet Requirements	2-4
Connecting a System Directly to Separate AC Sources	2-6
Selecting a UPS Unit for ftServer Systems	2-8
Communicating with a UPS over a Network	2-10
Connecting Power to Systems, PDUs, and a UPS	2-10
Connecting a System Directly to a UPS	2-12
Power Cord Summary	2-13
Power Cords for ftServer Systems and Peripheral	
Components	2-13
PDU Power Cords	2-14
Grounding Requirements	2-15

3. Space Planning	3-1
Room Requirements	3-1
Planning for Cables	3-3

4. Communications Line Planning	4-1
Supported Host Bus Adapters	4-2

Fibre Channel Connections	4-2
Ethernet Cables	4-7
iSCSI Connections (VMware-based Systems)	4-9
Telephone Line Connections	4-10
Telephone Line Connections in Australia and New Zealand	4-10
Site Planning for Systems in an ftGateway Group	4-11

5. Rack Configuration Planning	5-1
Using PDUs	5-1
Determining PDU Requirements	5-2
Example of PDU Usage Calculation	5-4

6. Cabinet and Monitor Requirements	6-1
Cabinet Requirements	6-1
Monitor Requirements	6-5

Appendix A. System Specifications	A-1
System Specifications	A-1
PCI Adapter Specifications	A-7
AAP87600 PDU Specifications	A-8

Appendix B. Electrical Circuit and Wiring Information	B-1
Fault Protection Requirements	B-1
Grounding Considerations	B-1
Circuit Wiring Diagrams	B-2
Electrical Power Connectors	B-9

Appendix C. Standards Compliance	C-1
Electronic Interference, Immunity, Safety, and Noise Level	
Standards Compliance	C-1
Toxic and Hazardous Substances and Elements Disclosure	C-4

Index	Index-1
--------------	---------

Figures

Figure 2-1.	System Connected Directly to AC Power	2-6
Figure 2-2.	PDUs Connected Directly to AC Power	2-7
Figure 2-3.	Power Cord Connections for Systems, PDUs, and a UPS	2-11
Figure 2-4.	Rack-Mountable Systems: A-Side Power Connected Directly to a UPS	2-12
Figure 4-1.	Fibre Channel Connections to an ftScalable Storage G2 System in a DAS Configuration	4-4
Figure 4-2.	Fibre Channel Connections to a First-Generation ftScalable Storage System in a DAS Configuration*	4-5
Figure 4-3.	Fibre Channel Connections to an ftScalable Storage G2 or First-Generation ftScalable Storage System in a SAN Configuration	4-6
Figure 6-1.	Rail Clearance	6-4
Figure A-1.	ftServer 2600, 4500, 6300, or 6310 System: CPU-I/O Enclosures: Front View	A-2
Figure A-2.	ftServer 2600, 4500, 6300, or 6310 System: Rear View	A-3
Figure A-3.	AAP87600 PDU	A-8
Figure B-1.	Star Ground Example	B-2
Figure B-2.	PDU Power Input Labeling	B-3
Figure B-3.	ftServer Enclosure Power Input Labeling	B-3
Figure B-4.	Single-Phase 120V AC Circuit Connection	B-4
Figure B-5.	Single-Phase 240V AC Circuit Connection	B-5
Figure B-6.	Split-Phase 120/240 Volts AC Circuit Connection	B-6
Figure B-7.	Three-Phase 208V AC, Y-, or D-Source Circuit Connection, Phase-to-Phase	B-7
Figure B-8.	Three-Phase 380V AC, Y-, or D-Source Circuit Connection, Phase-to-Neutral	B-8

Tables

Table 1-1.	Ethernet PCIe Adapters	1-4
Table 1-2.	ftServer 2600, 4500, 6300, and 6310 System Documentation	1-7
Table 1-3.	Additional System Documentation for Windows-based Systems	1-8
Table 1-4.	Additional System Documentation for Linux-based Systems	1-9
Table 1-5.	Additional System Documentation for VMware-based Systems	1-9
Table 2-1.	Worksheet: Determining A-Side Power Requirements	2-3
Table 2-2.	Worksheet: Determining B-Side Power Requirements	2-3
Table 2-3.	Worksheet: Determining External Power Requirements	2-4
Table 2-4.	HVAC Requirements	2-4
Table 2-5.	Worksheet: A-Side External Power Outlet Requirements: PDUs Used	2-4
Table 2-6.	Worksheet: B-Side External Power Outlet Requirements: PDUs Used	2-5
Table 2-7.	Worksheet: A-Side External Power Outlet Requirements: No PDUs	2-5
Table 2-8.	Worksheet: B-Side External Power Outlet Requirements: No PDUs	2-5
Table 2-9.	APC Symmetra Models for PDUs or for Multiple Systems	2-9
Table 2-10.	APC UPS Models for a Single Rack-Mountable System	2-9
Table 2-11.	Power Cords - ftServer Systems and Peripheral Components to AC Power	2-13
Table 2-12.	Power Cords Between ftServer Systems or Storage Systems and a UPS	2-14
Table 2-13.	Power Cords to Connect PDUs Directly to AC Power Mains	2-15
Table 2-14.	AC Power Cords to Connect PDUs to a UPS	2-15
Table 2-15.	System Power (<i>Jumper</i>) Cables to Connect ftServer Systems to PDUs	2-15
Table 4-1.	HBAs Supported by 2600, 4500, 6300, and 6310 Systems	4-2
Table 4-2.	Optical Fibre Channel Cables	4-3
Table 4-3.	Customer-Supplied Ethernet Cables	4-8
Table 5-1.	Current and Rack-Space Requirements	5-2
Table 5-2.	Calculating A-Side PDU and Rack-Space Requirements	5-3
Table 5-3.	Example: Current and Rack-Space Requirements (208 volts)	5-4

Table 5-4.	Example: Calculating A-Side PDU and Rack-Space Requirements	5-4
Table A-1.	Cabinet Dimensions	A-4
Table A-2.	ftServer 2600, 4500, 6300, or 6310 System: CPU-I/O Enclosure Specifications	A-5
Table A-3.	PCI Adapter Specifications	A-7
Table A-4.	AAP87600 PDU: Specifications	A-9
Table B-1.	Connectors for AC Power Outlets	B-9
Table C-1.	Compliance Standards for ftServer 2600, 4500, 6300, and 6310 Systems (Class A)	C-2

Preface

The *Stratus ftServer 2600, 4500, and 63x0 Systems: Site Planning Guide (R655)* documents the site requirements and customer responsibilities related to preparing a site for the installation of ftServer 2600, 4500, 6300, or 6310 systems.

This document is intended for those responsible for preparing a site for the installation of an ftServer 2600, 4500, 6300, or 6310 system.

Revision Information

This manual is a revision. It adds site-planning information for systems running ftServer System Software for VMware® vSphere™, Release 3.1.2.

Notation Conventions

This document uses the notation conventions described in this section.

Warnings, Cautions, and Notes

Warnings, cautions, and notes provide special information and have the following meanings:



WARNING _____

A warning indicates a situation where failure to take or avoid a specified action could cause bodily harm or loss of life.



CAUTION _____

A caution indicates a situation where failure to take or avoid a specified action could damage a hardware device, program, system, or data.

NOTE _____

A note provides important information about the operation of an ftServer system.

Typographical Conventions

The following typographical conventions are used in this document:

- The bold font emphasizes words in text or indicates text that you type, the name of a screen object, or the name of a programming element. For example:

Before handling or replacing system components, make sure that you are properly grounded by using a grounded wrist strap.

In the **System Properties** dialog box, click the **Hardware** tab.

Call the **RegisterDeviceNotification** function.

- The italic font introduces new terms and indicates programming and command-line arguments that the user supplies. For example:

Many hardware components are *customer-replaceable units* (CRUs), which can be replaced on-site by system administrators with minimal training or tools.

copy *filename1 filename2*

Pass a pointer for the *NotificationFilter* parameter

- The monospace font indicates sample program code and output, including message text. For example:

```
#include <iostream.h>
```

```
The operation completed successfully.
```

Typographical Conventions

The following typographical conventions are used in this document:

- The bold font emphasizes words in text. For example:

Before handling or replacing system components, make sure that you are properly grounded by using a grounded wrist strap.

- The italic font introduces new terms. For example:

Many hardware components are *customer-replaceable units* (CRUs), which can be replaced on-site by system administrators with minimal training or tools.

- The monospace font represents text that would appear on your display screen. The monospace bold font represents text you must type in examples that contain both user input and system output. The monospace italic font represents terms in command lines that are to be replaced by literal values. For example:

To display the state of a CPU enclosure, type a command in the following format:

```
/opt/ft/bin/ftsmaint ls n
```

If you type `/opt/ft/bin/ftsmaint ls 0` at the prompt, the following output appears:

```
H/W Path : 0
Description : CPU Node Assembly
.
.
.
```

- The percent sign (%) and number sign (#) are standard default prompt signs that have a specific meaning at a Linux command prompt. Although a prompt is sometimes shown at the beginning of a command line as it would appear on the screen, you do not type it.
 - % indicates you are logged in to a user account and are subject to certain access limitations.
 - # indicates you are logged in to the system administrator account and have *superuser* access. Users of this account are referred to as `root`. The # prompt sign used in an example indicates the command can only be issued by `root`.
- The dollar sign (\$) and number sign (#) are standard default prompt signs that have a specific meaning in the ESX™ Server console. Although a prompt is sometimes shown at the beginning of a command line as it would appear on the screen, you do not type it.
 - \$ indicates you are logged in to a user account and are subject to certain access limitations.
 - # indicates you are logged in to the system administrator account and have *superuser* access. Users of this account are referred to as `root`. The # prompt sign used in an example indicates the command can only be issued by `root`.

Getting Help

If you have a technical question about ftServer system hardware or software, try these online resources first:

- **Online documentation at the StrataDOC Web site.** Stratus provides complimentary access to StrataDOC, an online-documentation service that enables you to view, search, download, and print customer documentation. You can access StrataDOC at the following Web site:

<http://stratadoc.stratus.com>

A copy of StrataDOC on supported media for your system is included with this release. To order additional copies of the StrataDOC media or to obtain copies of printed manuals, do one of the following:

- If you are in North America, call the Stratus Customer Assistance Center (CAC) at (800) 221-6588 or (800) 828-8513, 24 hours a day, 7 days a week.
- If you are located outside North America, contact your nearest Stratus sales office, CAC office, or distributor; for CAC phone numbers outside the U.S., see <http://www.stratus.com/support/cac/index.htm>.
- **Online support from Stratus Customer Service.** You can find the latest technical information about an ftServer system through online product support at the Stratus Technical Support Web site:
<http://www.stratus.com/support/technics.htm>
- **Online product support for Microsoft® products.** Your primary source for support is the computer manufacturer who provided your software, or an authorized Microsoft Support Provider. You can also find the latest technical information about Microsoft Windows® and other Microsoft products through online product support at the [Microsoft Help and Support Web site](http://support.microsoft.com/):
<http://support.microsoft.com/>
- **Online product support for Red Hat® Linux® products.** Your primary source for support is the manufacturer who provided your software, or Red Hat Global Support Services. You can also find the latest technical information about Red Hat Enterprise and Standard Linux through online product support at the Red Hat Support Web site:
<http://www.redhat.com/apps/support/>
- **Online product support for VMware vSphere products.** You can find the latest technical information about VMware vSphere through online product support at the VMware Support Web site:

<http://www.vmware.com/support/>

If you are unable to resolve your questions with the help available at these online sites, and the ftServer system is covered by a service agreement, please contact the Stratus Customer Assistance Center (CAC) or your authorized Stratus service representative. For information about how to contact the CAC, see the following Web site:

<http://www.stratus.com/support/cac/>

Commenting on the Documentation

To provide corrections and suggestions on the documentation, send your comments in one of the following ways:

- By clicking the **site feedback** link at the bottom of a Help topic. Information to identify the topic is supplied in the StrataDOC Web Site Feedback form.
- By email to Comments@stratus.com. If it is possible, please include specific information about the documentation on which you are commenting:
 - For a printed document or a document in PDF format, include the title and part number from the Notice page and the page numbers.
 - For online documentation, include the Help subject and topic title.

This information will assist Stratus Information Development in making any needed changes to the ftServer system documentation. Your assistance is most appreciated.

Regulatory Notice

All regulatory notices are provided in the site planning guide for your system.

Chapter 1

Site Planning for ftServer 2600, 4500, 6300, and 6310 Systems

For an overview of required information and tasks you need to perform to prepare a site for ftServer 2600, 4500, 6300, and 6310 systems, see:

- [“Site Planning Overview” on page 1-1](#)
- [“Site Planning Checklist” on page 1-3](#)
- [“System Documentation” on page 1-7](#)
- [“Safety Notices” on page 1-10](#)

Site Planning Overview

Site planning for fault-tolerant systems includes:

- [Purchasing an appropriate cabinet and monitor](#)

If you do not purchase a monitor from Stratus, provide a monitor that meets the system’s requirements.

NOTE _____

A monitor, keyboard, and mouse are required to install ftServer System Software (ftSSS).

If you do not purchase a cabinet from Stratus, provide a cabinet that meets the system’s requirements.

- [Electrical power planning](#)

Provide electrical power sources that meet the requirements of the system and optional components, optionally including the purchase of a qualified [uninterruptible power supply \(UPS\)](#).

- **Space planning**

Provide adequate space for the system or cabinet and for a desk or table to accommodate components outside a cabinet. Also provide enough space for servicing the systems and components.

Provide an environment that meets the system's requirements for ambient temperature and air quality.

- **Communications line planning**

Provide sufficient network and analog telephone lines and plan the location of the system and external components to accommodate the lengths of the connecting cables.

- **Rack space planning**

Ensure that the power distribution units (PDUs) supply sufficient power to the components you have purchased and that you have sufficient space available in an appropriate cabinet.

Use the “[Site Planning Checklist](#)” on page 1-3 to track your site preparation progress.

For information about obtaining documents related to your ftServer system, see “[System Documentation](#)” on page 1-7.

During the site planning and preparation processes, work closely with your facilities group or contractor to determine space, power, and environmental requirements. Enlist their help to provide a suitable location with sufficient alternating current (AC) power, heating, ventilation and air conditioning (HVAC) capabilities, and network and telephone connections.

If your system is covered by a service agreement and you need help with site planning, contact the Stratus Customer Assistance Center (CAC) or your authorized Stratus service representative. If you have a contract with the CAC or your authorized Stratus service representative to install the system, contact them after you have prepared the installation site and moved the system to the site. For more information about the CAC, see [Getting Help](#) in the Preface or the <http://www.stratus.com/support/cac/> Web site.

See [Appendix A, “System Specifications”](#) for the specifications of the base ftServer systems and of PDUs. See the *Stratus ftServer Systems: Peripherals Site Planning Guide* (R582) for specifications of other components.

The Stratus ActiveService Network

The Stratus ActiveService Network (ASN) is a network that allows your ftServer system to automatically report problems to the Stratus Customer Assistance Center (CAC) or your authorized Stratus service representative, and that can allow the CAC or your

authorized Stratus service representative to remotely diagnose, troubleshoot, and resolve problems online.

To enable connectivity to the ASN, you connect a pair of partnered Ethernet ports, one from each CPU-I/O enclosure in your system, to a network that has Internet access. For additional protection, if you connect the Ethernet port of the VTM in each enclosure to a network with Internet access, the VTMs can communicate with the ASN even when the host operating system is not running or is unresponsive.

If Internet access is not available, or if you wish to have a backup method of connecting to the ASN, you can also install the optional ASN modem in your system, which allows either the host operating system or a VTM to communicate with the ASN through a telephone dialup connection.

Site Planning Checklist

Referring to the information in this document, answer the following questions:

Planning for ASN Connectivity

- Will your system connect to the ASN? If so, will it connect over an ASN modem or the Internet?
- If your system will use the Internet to connect to the ASN, do you have an Internet connection available?
- If your system will use an ASN modem, do you have an external analog telephone line available for the ASN modem?

NOTE _____

A dedicated phone line provides the most reliable service. ASN calls routed through a PBX may be slow due to load on the PBX, or may not complete successfully due to disconnections. If you must use a PBX, do not route the telephone extension through a switchboard; instead, provide a direct-dial analog number.

- Do you have an additional telephone connection and telephone near the operator's station for voice communications when calling for support?

Planning for Network Connectivity

- The system contains four embedded 10/100/1000 megabits-per-second (Mbps) Ethernet ports. You can add optional Ethernet PCI adapters to provide additional Ethernet bandwidth. Will your system additionally include any of the following PCI adapters? If so, in [Table 1-1](#), indicate the total number of ports, and plan network connections for all Ethernet ports you will use.

Table 1-1. Ethernet PCIe Adapters

Adapter	Total Number of Ports
Embedded Dual-Port 10/100/1000 Base-T Ethernet PCI-Express Adapters (2)	4
U104 Dual-Port Fiber Gigabit Ethernet PCI-Express Adapter	
U105 Dual-Port 10/100/1000 Base-T Ethernet PCI-Express Adapter	
U108 Single-Port Fiber 10-Gigabit Ethernet PCI-Express Adapter†	

† Requires installation in the optional PCI riser assembly, not available for ftServer 2600 systems.

NOTE _____

The combined four ports of the two embedded physical adapters provide the basic requirements for VMware ESX software: one port of each adapter dedicated to the service console and the other port of each adapter dedicated to the virtual machines or VMkernel traffic.

Planning for External Storage Options

- ❑ Will your system connect to external Fibre Channel storage enclosures? If so, the system requires a pair of Fibre Channel HBAs, which are provided when you order the storage enclosure. If you order the enclosure at the same time you order the system, the required Fibre Channel HBAs are installed at the factory. See the *Stratus ftServer Systems: Peripherals Site Planning Guide (R582)* for descriptions of the storage enclosures provided by Stratus and the names of the PCI adapters required for supported storage enclosures.

NOTES _____

1. ftServer systems support first-generation ftScalable™ Storage systems, ftScalable Storage G2 systems, and EMC® CLARiiON® or Symmetrix® storage systems.

If you plan to connect an EMC storage system to an ftServer system running the Linux operating system or VMware ESX, ensure that you have received approval for your configuration by submitting a request through EMC's Request for Price Quote (RPQ) process to guarantee EMC support.

2. ftServer systems that run the Linux operating system additionally support Hewlett-Packard® (HP) StorageWorks® Enterprise Virtual Array (EVA) storage system models 4000, 6000, or 8000, connected through a SAN.

If you plan to connect an HP EVA storage system to an ftServer system running the Linux operating system, ensure that your configuration has received ftReady certification to guarantee Stratus support.

- Will your system connect to external Fibre Channel storage enclosures in a storage area network (SAN) configuration? If so, do you have a minimum of two switches that can accommodate the cables from the pair of Fibre Channel HBAs in each ftServer system?

NOTE _____

Stratus has successfully tested the Brocade® 200E and 5100 Fibre Channel switches. Other model switches may also be compatible as long as they can be configured in the same manner as the Brocade 200E or 5100 switch.

- Will your ftServer system running VMware ESX connect to external iSCSI storage enclosures? If so, ensure that your system has adequate Ethernet adapter bandwidth. Contact your account representative for information about iSCSI storage systems qualified for use with ftServer systems.

Planning for Optional Components

- Will you supply your own monitor or will Stratus supply the monitor, keyboard, and mouse? Is the monitor rack-mountable or do you need to provide a table or desk?
- Will you connect an SAS tape drive to your system?

NOTE _____

ftSSS for VMware vSphere does not support tape drives.

Planning AC Power

- Will you provide power to both sides of the system through a pair of PDUs?
- If your system is running the Windows operating system or VMware ESX, will you protect the system power with a UPS?
- What optional components will you use?
- What are the AC power requirements of your system, including all optional components?

- What are the lengths and types of the power cords that are provided for the PDUs or system, and optional components?
- What type of AC receptacles do you need to provide?
- Is the AC power service wired properly?

Planning Space for Your System

- Will your system and its external components fit where you plan to place them?
- What is the height of the cabinet you will use, and what is the total height of the systems and components that will be installed in the cabinet? Will the items fit into the cabinet? What components will be located outside the cabinet?
- What are the lengths and types of the interface and communications cables that will connect to your system?
- Have you created a sketch of how you plan to arrange the system at the installation site? Consider the available cable lengths, the placement of external devices, and the location of network and voice communication connections.

On the sketch, show the following:

- Location of the system and its external components
- Power cords, and telephone and interface cables
- Locations of AC power receptacles, phone jacks, Ethernet jacks, switches, and hubs

NOTE _____

Make sure that all cords and cables are long enough to reach between their respective components and connectors. Route all cables out of the way of foot traffic.

Working with Other Groups

- Have you provided your facilities group and contractors with the sketch of how you plan to arrange the system and copies of the following?
 - [“AC Power and HVAC Service Requirements” on page 2-2](#)
 - [“Redundant Power Sources” on page 2-1](#)
 - Tables [2-1](#), [2-2](#), and [2-3](#), worksheets for determining AC power requirements
 - Tables [2-5](#) and [2-6](#) (if you are using PDUs) or Tables [2-7](#) and [2-8](#) (if you are not using PDUs), worksheets for determining the number of external power outlets required
 - [Appendix B, “Electrical Circuit and Wiring Information”](#)
 - Any notes you have about site planning

- ❑ Have you reviewed and discussed the requirements with the facilities personnel and contractors to ensure that all site modifications are understood and implemented?

If you have any questions about the number and types of components, contact your Stratus account representative or distributor.

System Documentation

[Table 1-2](#) lists the hardware documents for ftServer 2600, 4500, 6300, and 6310 systems, and the tasks described in each document. Also see [Table 1-3](#) (for Windows-based systems) or [Table 1-4](#) (for Linux-based systems) or [Table 1-5](#) (for VMware-based systems).

Table 1-2. ftServer 2600, 4500, 6300, and 6310 System Documentation

Document	Task
<i>Stratus ActiveService Network Configuration Guide (R072)</i>	Configure your system for support by the ASN
<i>Stratus ftServer Systems: PCI Adapter Guide (R461)</i>	Install, configure, replace, or troubleshoot PCI adapters
<i>Stratus ftServer Systems: Technical Reference Guide (R550)</i>	Consult technical reference information for ftServer systems Change BIOS settings in the ftServer Setup program
<i>Stratus ftServer Systems: Peripherals Site Planning Guide (R582)</i>	Find information about optional equipment that you have ordered with your system that is needed to complete site preparation
<i>Stratus ftServer 2600, 4500, and 63x0 Systems: Operation and Maintenance Guide (R656)</i>	Start up, shut down, and operate your system Troubleshoot system hardware Remove and replace CRUs, including PCI adapters
<i>Stratus ftServer 2600, 4500, and 63x0 Systems: Hardware Installation Guide (R657)</i>	Install your system, including mounting the system in a cabinet
<i>Readme First: Unpacking ftServer 2600, 4500, and 63x0 Systems (R658)</i>	Inspect and unpack ftServer system hardware that you install in your cabinet

[Table 1-3](#) lists additional documents for ftServer 2600, 4500, 6300, and 6310 systems that run ftSSS for the Windows operating system, and the tasks described in each document.

Table 1-3. Additional System Documentation for Windows-based Systems

Document	Task
<i>Release Notes: Stratus ftServer System Software for the Windows Operating System (R004W)</i>	Learn the contents of the latest ftServer System Software release Learn the latest information about the product Learn about significant known problems and how to work around or avoid the problems
<i>Stratus ftServer System Software: Installation and Configuration for Windows-Based Systems (R002W)</i>	Respond to Mini-Setup questions Install or reinstall ftSSS and Windows Server software Install the operating system on your new system Upgrade software and BIOS and BMC firmware Configure ftSSS Set up your system to communicate with a UPS Configure VTMs
<i>Stratus ftServer System Administrator's Guide for the Windows Operating System (R014W)</i>	Use tools that are provided by the operating system software, ftServer System Software, and other vendors to manage and troubleshoot the system Manage data-storage devices
<i>Stratus ftServer Virtual Technician Module User's Guide (R642)</i>	Use the VTM console to remotely control, monitor, and troubleshoot your system

[Table 1-4](#) lists additional documents for ftServer 2600, 4500, 6300, and 6310 systems that run ftSSS for the Linux operating system, and the tasks described in each document.

Table 1-4. Additional System Documentation for Linux-based Systems

Document	Task
<i>Release Notes: Stratus ftServer System Software for the Linux Operating System (R005L)</i>	<p>Learn the contents of the latest ftServer System Software release</p> <p>Learn the latest information about the product</p> <p>Learn about significant known problems and how to work around or avoid the problems</p>
<i>Stratus ftServer System Software: Installation for Linux Systems (R013L)</i>	Install and update the Linux operating system, ftServer System Software, and BIOS and BMC firmware
<i>Stratus ftServer System Administrator's Guide for the Linux Operating System (R003L)</i>	<p>Use tools that are provided by the operating system software, ftServer System Software, and other vendors to manage and troubleshoot the system</p> <p>Manage network connections and data storage devices</p> <p>Install and configure the Simple Network Management Protocol</p>
<i>Stratus ftServer Virtual Technician Module User's Guide (R642)</i>	Use the VTM console to remotely control, monitor, and troubleshoot your system

[Table 1-5](#) lists additional documents for ftServer 4500 and 6300 systems that run ftSSS for VMware vSphere, and the tasks described in each document.

Table 1-5. Additional System Documentation for VMware-based Systems

Document	Task
<i>Release Notes: Stratus ftServer System Software for VMware vSphere (R001E)</i>	<p>Learn the contents of the latest ftServer System Software release</p> <p>Learn the latest information about the product</p> <p>Learn about significant known problems and how to work around or avoid the problems</p>
<i>Stratus ftServer System Software: Installation and Configuration for VMware vSphere Systems (R004E)</i>	Install, update, and configure VMware ESX, ftServer System Software, and BIOS and BMC firmware.

Table 1-5. Additional System Documentation for VMware-based Systems (Continued)

Document	Task
<i>Stratus ftServer System Administrator's Guide for VMware vSphere (R002E)</i>	Use tools that are provided by VMware vSphere, ftServer System Software, and other vendors to manage and troubleshoot the system Manage data storage devices
<i>Stratus ftServer Virtual Technician Module User's Guide (R642)</i>	Use the VTM console to remotely control, monitor, and troubleshoot your system
<i>VMware iSCSI SAN Configuration Guide</i> [†]	Learn how to set up and manage a system using VMware vSphere with external iSCSI storage systems
<i>VMware Fibre Channel SAN Configuration Guide</i> [†]	Learn how to set up and manage a system using VMware vSphere with Fibre Channel storage area networks (SANs)

† Available from VMware at <http://www.vmware.com/support/pubs/>.

Safety Notices



WARNING

Risk of explosion if battery is replaced by an incorrect type. Dispose of used batteries according to the instructions provided with the battery.



WARNING

The system uses two power cords to provide redundant sources of power. To fully remove power from a system, disconnect both power cords. To reduce the risk that electrical shock could injure a person or damage the system, exercise caution when working in the unit even when only one power cord is connected.



WARNING

To prevent a cabinet from tipping over and injuring a person or damaging the system, start installing systems from the bottom of the cabinet upward.

**WARNING** _____

If you replace the modem cable supplied by Stratus, use a cable with a gauge of at least 26 AWG to prevent fire.

**WARNING** _____

To avoid fire, electric shock, and equipment breakdown, prevent water or foreign objects from getting into the equipment. Do not let water or foreign objects, such as pins or paper clips, enter the equipment.

**WARNING** _____

To prevent fire or current leakage, do not plug the power cord into a nonconforming outlet. Use a power outlet with appropriate voltage and power type, as specified in this guide.

**WARNING** _____

Do not install the equipment where you may need an extension cord. Use of an extension cord that does not meet the power specifications introduces a risk of overheating that could lead to a fire.

**WARNING** _____

Disconnect the power cords from the server or power source before you install or relocate the equipment. All voltage is removed only when the power cords are disconnected.



WARNING _____

Do not install or store the equipment in an unsuitable place. Install or store the equipment in a place that meets the requirements specified in this guide. Avoid the following conditions to avoid the risk of fire:

- **Dust**
- **High humidity, such as a place near a boiler**
- **Direct sunlight**
- **Instability, such as places not stabilized against earthquakes**



WARNING _____

Do not use or store this product in a corrosive environment.

Avoid using or storing this product in an environment which may contain corrosive gases. Such gases include, but are not limited to, sulfur dioxide, hydrogen sulfide, nitrogen dioxide, chlorine, ammonia or ozone.

Avoid installing this product in a dusty environment or one that may contain corrosive materials such as sodium chloride or sulfur.

Avoid installing this product in an environment which may contain excessive metal flakes or conductive particles in the air.

Such environments may cause corrosion or short circuits within this product, resulting in not only damage to this product, but also fire.

If there are any concerns regarding the environment at the planned site of installation or storage, please contact your CAC or your authorized Stratus service representative.

**WARNING** _____

When installing a system or CRU, always connect the power cord first, before adding communications cables. The power cord contains the protective earth connection; it should be connected first and disconnected last, to maintain a grounded chassis.

Before attempting to remove a CRU from the system chassis, make sure to power off the CRU, disconnect communications cables, and then disconnect the power cord.

Never connect a power cord to a CRU when it is not located within the system chassis.

**WARNING** _____

Do not disassemble, repair, or alter the server, except as described in the *Stratus ftServer 2600, 4500, and 63x0 Systems: Operation and Maintenance Guide* (R656). There is a risk of an electric shock or fire as well as equipment malfunction if you do not observe the instructions in the *Stratus ftServer 2600, 4500, and 63x0 Systems: Operation and Maintenance Guide* (R656).

**WARNING** _____

Do not place any object on top of the server. The object may fall off and cause injuries, damage to hardware, or a fire.

**WARNING** _____

Do not leave the DVD tray ejected. Dust may enter the equipment and cause it to malfunction. The ejected tray may also become a cause of injuries.

安全注意事項



WARNING

若錯誤更換電池類型，將產生爆炸風險。請按電池包裝說明，妥善丟棄已耗廢電池。



WARNING

系統採用兩條電源線，以提供冗餘電源。欲徹底清除系統電源，先拔下兩條電源線。為降低觸電所導致的人體傷害或系統損害，請小心操作機體，即使系統僅插入一條電源線。



WARNING

欲預防儲櫃翻倒，進而導致人體傷害或系統損害，請從儲櫃下方開始往上安裝系統。



WARNING

若您更換由Stratus供應的數據機纜線，請使用至少有26 AVG壓力的纜線，避免發生火災。



WARNING

避免火災、觸電、設備故障、液體或其他異物進入設備。不得讓液體或類似圖釘或迴紋針等異物進入設備。



WARNING

為避免火災或漏電，不得將電源線插入規格不符的的插座中。請使用本指南指定之電壓及電源類別的的插座。

**WARNING**

不得使用延長線安裝設備。使用與指定電源規格不符的延長線會產生設備過熱風險，進而可能導致火災。

**WARNING**

安裝或移動設備前，請從伺服器或電源拔下電源插頭。

只有在拔下電源線後，設備的所有電壓才會消除。

**WARNING**

不得在不適合場所安裝或存放設備。請按本指南指定且符合規格要求的場所安裝或存放設備。避免下列可能產生火災風險的地方：

- 灰塵較多
- 熱水器旁濕氣較重的地方
- 陽光直照的地方
- 不穩位置，例如易受地震影響的地方

**WARNING**

不得在腐蝕性環境中使用或存放產品。避免在含腐蝕性氣體的環境使用或存放本產品，其中包括但不限於：二氧化硫、硫化氫、氯、氫、氨或臭氧。

不得將本產品安裝在灰塵較多或含類似氯化鈉或硫磺等腐蝕性物質的地方。

不得將本產品安裝在空氣中含過量金屬碎片或傳導粒子的地方。

上述環境可能導致本產品腐蝕或短路，因而損壞產品，甚至引起火災。若對產品安裝或存放的場地環境規劃有任何疑問，請與CAC或授權Stratus服務代表聯絡。



WARNING

不得在伺服器已連接電源的狀態下連接界面電纜。安裝或移除任何內建裝置，或從伺服器拔下或連接任何界面電纜前，確認已關閉伺服器的電源，並從伺服器或電插座拔下電纜線。即使伺服器電源已切斷，在仍連接電源的狀態下，碰觸內建裝置、電纜或連接器也可能產生觸電、或因短路而引起火災。



WARNING

除 *Stratus ftServer 2600*、*4500* 和 *63x0* 系統：操作和維修指南 (R656) 之說明外，不得以任何方式拆卸、修理或改裝伺服器。若未遵循 *Stratus ftServer 2600*、*4500* 和 *63x0* 系統：操作和維修指南 (R656) 的說明指示，將可能產生觸電、火災以及設備故障的風險。



WARNING

不得在伺服器上放置任何物件。物件可能會掉落而導致人體傷害、硬體損壞或火災。



WARNING

DVD 光碟機不得靜置於彈出位置。灰塵進入設備將導致功能異常。彈出的光盤也可能是導致設備損壞的來源。

Chapter 2

Electrical Power Planning

For information about planning appropriate AC electrical power for your system and its peripheral components, see:

- [“Redundant Power Sources” on page 2-1](#)
- [“AC Power and HVAC Service Requirements” on page 2-2](#)
- [“Selecting a UPS Unit for ftServer Systems” on page 2-8](#)
- [“Power Cord Summary” on page 2-13](#)
- [“Grounding Requirements” on page 2-15](#)

Related Topic

- [Chapter 5, “Rack Configuration Planning”](#)

Redundant Power Sources

ftServer systems require at least two separate and independent AC power sources—an *A-side* power source and a *B-side* power source—that provide power to the system’s power receptacles, labeled A and B, respectively. Either source must be capable of continuing to provide power if power to the other source is lost.

The A-side power source provides power to one side of each system and storage enclosure, as well as to components that do not require two sources of power, such as tape-drive enclosures and a monitor. If you use an uninterruptible power supply (UPS), the UPS is, in these standard, documented, configurations, the A-side power source.

The B-side power source provides power to the other side of each system and storage enclosure.

The wattage required from the A-side power source will always be equal to or greater than the wattage required from the B-side power source.

AC Power and HVAC Service Requirements

From the *Stratus ftServer Systems: Peripherals Site Planning Guide* (R582), obtain the nominal input line voltage (volts AC) and frequency (Hz) required for optional, AC-powered components. In general, provide 100–127 VAC or 200–240 VAC at 50 or 60 Hz for optional components. PDUs require 200–240 VAC at 50 or 60 Hz. Operating the system at the higher end of the voltage range, when possible, results in higher power system efficiency and consequently less generated heat and lower utility costs.

For detailed information about the plug types and lengths of the power cords provided with the system, see [“Power Cord Summary” on page 2-13](#).

The power service must be properly wired and grounded according to local standards and regulations. See [Appendix B, “Electrical Circuit and Wiring Information”](#) for more information.

NOTE

A branch circuit breaker with ground fault protection must allow a minimum of 3.5 milliamperes (mA) leakage current for each power cord.

Use the following worksheets to determine AC power requirements for the site.

- In [Table 2-1](#), determine the power requirements at the A-side power source.
- In [Table 2-2](#), determine the power requirements at the B-side power source.
- In [Table 2-3](#), determine the power requirements for components outside of the cabinet. These components can share a power source with the A-side or B-side components.
- In [Table 2-4](#), determine the related HVAC requirements.

To determine AC power requirements

Provide information in [Tables 2-1](#), [2-2](#), and [2-3](#) as follows:

1. In the Quantity column, write the number of each type of component.
2. Multiply the entry in the Quantity column by the number in the Watts column, and enter the result in the Watts Subtotal column.
3. Add the values in the Watts Subtotal column, and enter the sum on the bottom line. This value indicates the maximum power requirement for each power source.

Table 2-1. Worksheet: Determining A-Side Power Requirements

System Component	Quantity	Watts	Watts Subtotal
ftServer systems		x 700	
Monitor unit [†]		x	
Storage enclosure [‡]		x	
Fibre Channel switch [‡]		x	
User-supplied components			
TOTAL A-SIDE POWER REQUIREMENTS			

[†] See the *Stratus ftServer Systems: Peripherals Site Planning Guide* (R582) for the wattage of optional components you purchase from Stratus.

[‡] If you are using Fibre Channel switches to connect the systems to storage enclosures, include on this line the power requirements for a Fibre Channel switch. Two switches are required for fault-tolerant operation. Connect one switch to A-side power and the other switch to B-side power.

Table 2-2. Worksheet: Determining B-Side Power Requirements

System Component	Quantity	Watts	Watts Subtotal
ftServer systems		x 700	
Storage enclosure [†]		x	
Fibre Channel switch [‡]		x	
User-supplied components			
TOTAL B-SIDE POWER REQUIREMENTS			

[†] See the *Stratus ftServer Systems: Peripherals Site Planning Guide* (R582) for the wattage of optional components you purchase from Stratus.

[‡] If you are using Fibre Channel switches to connect the systems to storage enclosures, include on this line the power requirements for a Fibre Channel switch. Two switches are required for fault-tolerant operation. Connect one switch to A-side power and the other switch to B-side power.

Table 2-3. Worksheet: Determining External Power Requirements

System Component	Watts
Other peripheral components	
TOTAL EXTERNAL POWER REQUIREMENTS	

To determine HVAC requirements

1. Add together the values from the Total row of Tables 2-1, 2-2, and 2-3 and enter the value in the Total Watts column of Table 2-4.
2. Multiply the value in the Total Watts column by 3.41 and enter the number of BTUs in the BTUs/hr. Subtotal column.

Table 2-4. HVAC Requirements

Total Watts (From Tables 2-1, 2-2, and 2-3)	Convert to BTUs	BTUs/hr. Subtotal
	x 3.41 =	

AC Power Outlet Requirements

If you **do** use a pair of PDUs in the cabinet, use Tables 2-5 and 2-6 to determine the total number of power outlets required **outside the cabinet**.

1. In the Quantity column, write the number of each type of component.
2. Multiply the value in the Quantity column by the value in the Outlets column, and enter the total in the Subtotal column.
3. Add the values in the Subtotal column and enter the sum next to TOTAL NUMBER OF A-SIDE POWER OUTLETS and TOTAL NUMBER OF B-SIDE POWER OUTLETS.

Table 2-5. Worksheet: A-Side External Power Outlet Requirements: PDUs Used

Component	Quantity		Outlets	Subtotal
PDUs		x	1	
Other external components				
TOTAL NUMBER OF A-SIDE POWER OUTLETS				

Table 2-6. Worksheet: B-Side External Power Outlet Requirements: PDUs Used

Component	Quantity		Outlets	Subtotal
PDUs		x	1	
Other external components				
TOTAL NUMBER OF B-SIDE POWER OUTLETS				

If you do **not** use PDUs in the cabinet, use Tables 2-7 and 2-8 to determine the number of AC power outlets required **outside the cabinet**.

1. In the Quantity column, write the number of each type of component.
2. Multiply the value in the Quantity column by the value in the Outlets column, and enter the total in the Subtotal column.
3. Add the values in the Subtotal column and enter the sum next to TOTAL NUMBER OF A-SIDE POWER OUTLETS and TOTAL NUMBER OF B-SIDE POWER OUTLETS.

Table 2-7. Worksheet: A-Side External Power Outlet Requirements: No PDUs

Component	Quantity		Outlets	Subtotal
ftServer systems		x	1	
Storage enclosures		x	1	
LCD monitor units or external monitors		x	1	
Tape-drive enclosure		x	1	
Other peripheral components				
TOTAL NUMBER OF A-SIDE POWER OUTLETS				

Table 2-8. Worksheet: B-Side External Power Outlet Requirements: No PDUs

Component	Quantity		Outlets	Subtotal
ftServer systems		x	1	
Storage enclosures		x	1	
Other peripheral components				
TOTAL NUMBER OF B-SIDE POWER OUTLETS				

Connecting a System Directly to Separate AC Sources

If you do not connect your ftServer system or PDUs to a UPS, provide two AC power sources that are as electrically independent of each other as the installation site allows.

At a minimum, the two power sources must be powered by separate circuit breakers (maximum of 20A) to AC power and, if possible, be independent of each other beyond that level. The more electrical separation between the two power sources, the less likely they will both fail at the same time. Due to redundancy in ftServer systems, power to either side of the system keeps the system in operation, although the system is no longer fault-tolerant.

Figure 2-1 shows how to connect rack-mounted ftServer 2600, 4500, 6300, and 6310 systems directly to two separate AC power sources. Figure 2-2 shows how to connect PDUs directly to two separate power sources.

Figure 2-1. System Connected Directly to AC Power

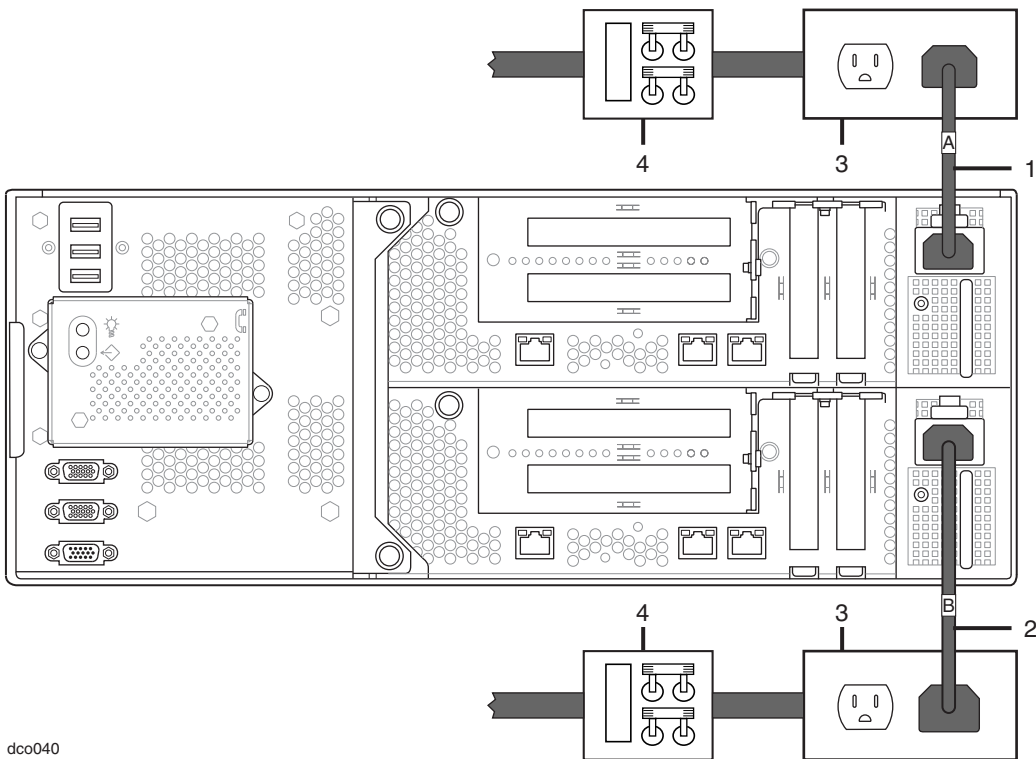

dco040

- | | | | |
|---|-------------------|---|-----------------------------------|
| 1 | A-side power cord | 3 | AC power outlets |
| 2 | B-side power cord | 4 | Circuit breakers (maximum of 20A) |

Figure 2-2. PDUs Connected Directly to AC Power

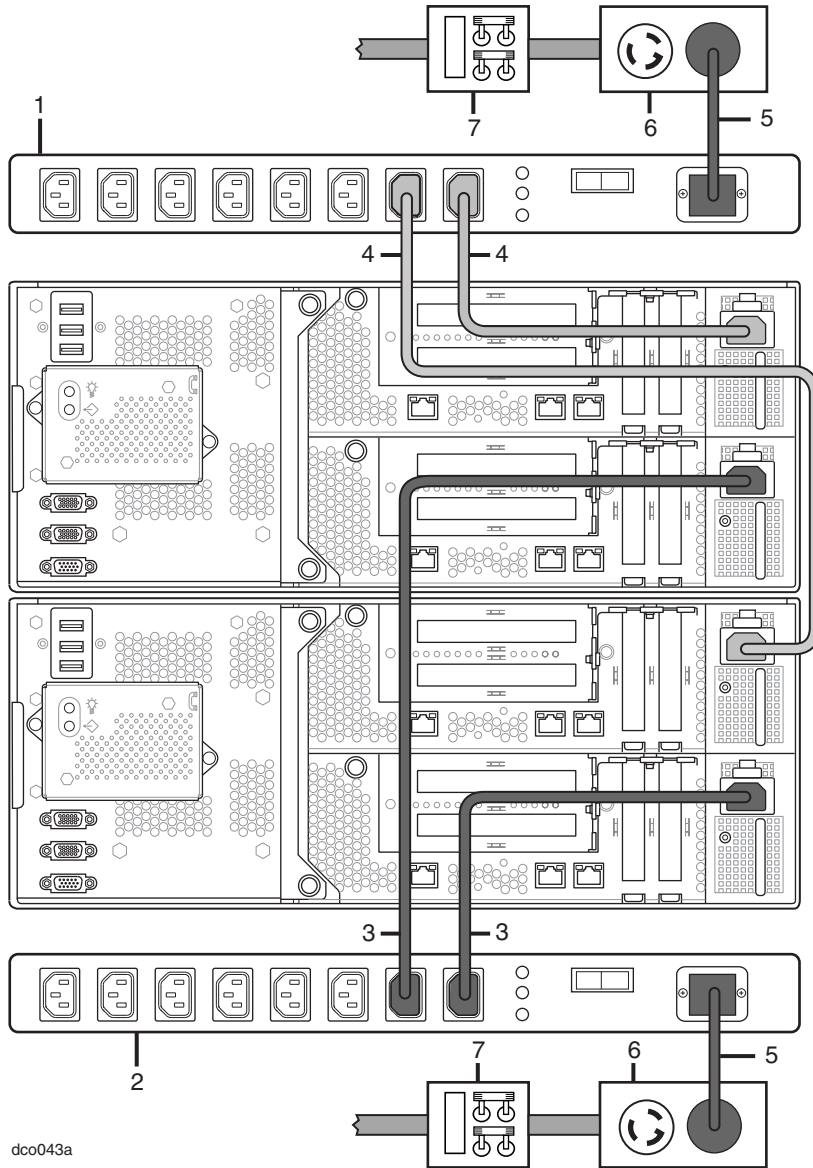

- | | | | |
|---|----------------------|---|-----------------------------------|
| 1 | A-side PDU | 5 | PDU power cords |
| 2 | B-side PDU | 6 | AC power outlets |
| 3 | B-side jumper cables | 7 | Circuit breakers (maximum of 20A) |
| 4 | A-side jumper cables | | |

Selecting a UPS Unit for ftServer Systems

Stratus does not sell or service UPS units. However, Stratus has qualified UPS models for use with ftServer 2600, 4500, 6300, and 6310 systems.

Use [Table 2-1](#) to determine the number of watts the A-side of your system requires and use [Table 2-9](#) and [2-10](#) to select a UPS model.

NOTES

1. Generally, system fault tolerance could be at risk if you use a UPS with systems that run ftSSS for the Linux operating system. These versions of ftSSS do not include the logic to decide whether the operating system should shut down in response to certain signals from the UPS, and the UPS may unnecessarily shut down the system.

If you have a situation that requires the use of a UPS (for example, if you do not have two separate power sources at the installation site), use the tables in this section to select an appropriate UPS, do **not** use UPS signaling, and contact the CAC or your authorized Stratus service representative for additional assistance.

2. Site planning information for the UPS in this document is of a general nature only. Do not rely exclusively on the UPS information in this document. Contact APC at <http://www.apcc.com> for detailed UPS specifications, documentation, sizing, and ordering information.

Table 2-9. APC Symmetra Models for PDUs or for Multiple Systems

Locale	APC Symmetra Model	UPS Input	UPS Output
North America	SYH2K6RMT, SYH4K6RMT, SYH6K6RMT Requires AAP87600 PDU with B50171F power cord	208V	208V (L6-20R)
	SYH2K6RMT-P1, SYH4K6RMT-P1, SYH6K6RMT-P1	208V	120/208V (L6-20R, 5-15R)
	SYA8K16RMP, SYA12P16RMP, SYA14K16RMP Requires APC SYPD7 and AAP87600 PDU	208V	120/208V (L6-20R, L6-30R)
Japan	SYH2K6RMJ, SYH4K6RMJ, SYH6K6RMJ Requires AAP87600 PDU with B50175F power cord	200V	200V (L6-20R)
	SYH2K6RMJ-P1, SYH4K6RMJ-P1, SYH6K6RMJ-P1	200V	100/200V (L6-20R, 5-15R)
	SYA8K16RMJ, SYA2K16RMJ, SYA16K16RMJ Requires APC SYPD7 and AAP87600 PDU	200V	100/200V (L6-20R, L6-30R)
Rest of the world	SYH2K6RMI, SYH4K6RMI, SYH6K6RMI Requires AAP87600 PDU with B52700F power cord	230V	230V (C20, C19)
	SYA8K16RMP, SYA12P16RMP, SYA14K16RMP Requires AAP87600 PDU with B52700F power cord	230V	230V (C20, C19)

Table 2-10. APC UPS Models for a Single Rack-Mountable System

Locale	Smart-UPS	UPS Input	AC Power Output
North America	Model SUA1500RM2U	120V	120V (5-15R)
Japan	Model SUA1500RMJ2UB	100V	100V (5-15R)
Rest of the world	Model SUA1500RMI2U	230V	230V (C14, C13)

Communicating with a UPS over a Network

Use the following additional tools to enable a UPS and an ftServer system that runs the Windows operating system or VMware ESX to communicate over the network:

- APC UPS Network Management Card 2 (APC part number AP9630)

An APC UPS Network Management Card 2 is a standard component of the Symmetra UPS, but you must purchase the network card for the APC Smart-UPS.

- APC PowerChute® Network Shutdown for the ftServer system

Before you install your ftServer system, purchase PowerChute Network Shutdown from APC. When you install your ftServer system, download PowerChute Network Shutdown from APC, and install and configure the tool on the system, as described in *Stratus ftServer System Software: Installation and Configuration for Windows-Based Systems (R002W)* or *Stratus ftServer System Software: Installation and Configuration for VMware vSphere Systems (R004E)*. PowerChute Network Shutdown monitors the UPS for an imminent power loss, and initiates an orderly shutdown of the system before power is lost.

Connecting Power to Systems, PDUs, and a UPS

When you plan for PDUs and a UPS, note the following:

- Only the top PDU is connected to the UPS.
- The bottom PDU is connected directly to an AC power main.
- The UPS can be connected to the same AC power main that the bottom PDU is connected to, or the UPS can be connected to another AC power main.

[Figure 2-3](#) shows how to connect rack-mounted systems to PDUs and the PDUs to UPS units.

Figure 2-3. Power Cord Connections for Systems, PDUs, and a UPS

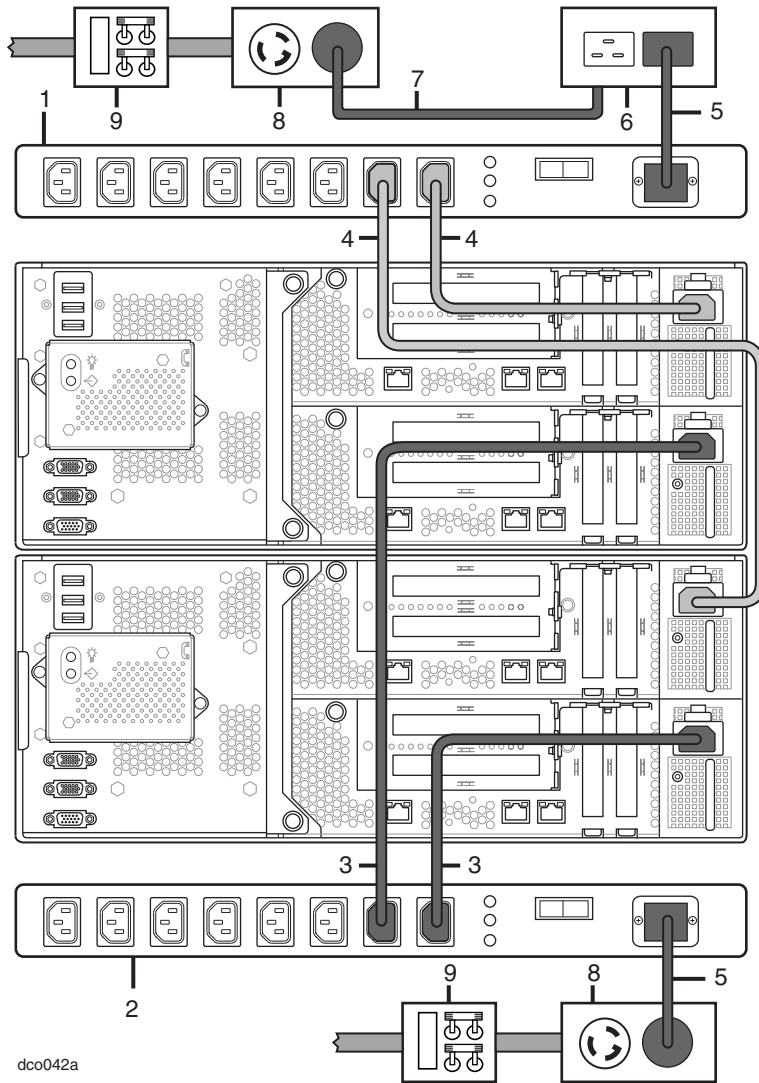

dco042a

- | | | | |
|---|------------------------------------|---|--|
| 1 | A-side PDU | 6 | UPS |
| 2 | B-side PDU | 7 | UPS power cord |
| 3 | B-side system power cables (black) | 8 | AC power outlets |
| 4 | A-side system power cables (gray) | 9 | AC power (mains) distribution circuit breaker (maximum of 20A) |
| 5 | PDU power cords | | |

Connecting a System Directly to a UPS

You can connect the A-side power connectors of your system directly to a UPS, as shown in [Figure 2-4](#).

Figure 2-4. Rack-Mountable Systems: A-Side Power Connected Directly to a UPS

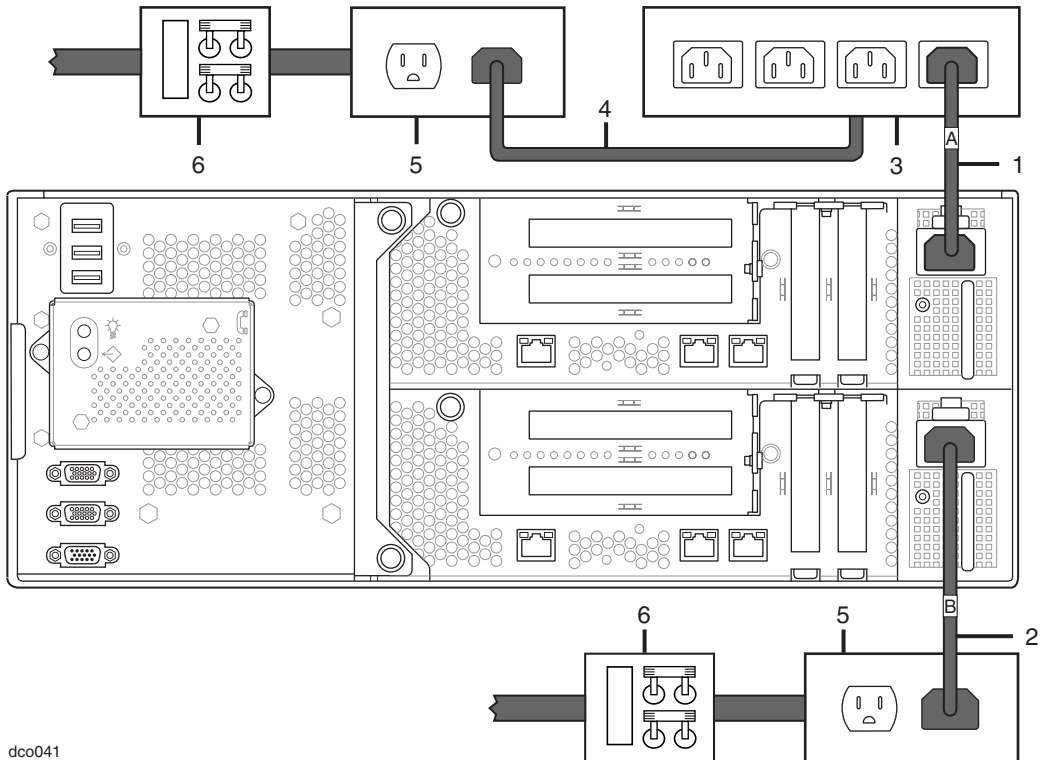

dco041

- 1 A-side system power cord
- 2 B-side system power cord
- 3 UPS
- 4 UPS power cord
- 5 AC power outlets
- 6 Circuit breakers (maximum of 20A)

Power Cord Summary

Stratus supplies tested and approved AC power cords for the following components:

- [ftServer systems and peripheral components](#)
- [PDUs](#)



WARNING

Place all power cords out of the way of foot traffic.

Power cords described as Domestic are made with American Wire Gauge (AWG) cordage and are intended for use in North America. Refer to UL 62 and CSA C22.2, No. 49. All other power cords are made with International cordage and are intended for use in the specified countries, and other countries that use that standard.

Power Cords for ftServer Systems and Peripheral Components

[Table 2-11](#) lists the available power cords that connect ftServer systems and peripheral components directly to an AC power source (not to a PDU or to a UPS).

[Table 2-12](#) lists the available power cords that connect ftServer systems to [qualified UPS models](#) from APC.

Table 2-11. Power Cords - ftServer Systems and Peripheral Components to AC Power

Marketing ID	Plug Type	Rating	Length	Locale
B50101F	NEMA 5-15, UL/CSA approved	15A/127V	7 ft	North America (Domestic)
B50104F	NEMA 5-15, UL/CSA approved	15A/127V	15 ft	North America (Domestic)
B50112F	CEE 7 VII	16A/250V	4.5m	Europe (Continental)
B50116F	BS 1363/A,	13A/250V	4.5m	United Kingdom
B50124F	AS/NZS 3112:1993	10A/250V	4.5m	Australia
B50140F	SEV 1011-S24507	10A/250V	4.5m	Switzerland
B50152F	SABS164-1:1992 ZA/3	13A/250V	4.5m	South Africa/India
B50153F	IEC 60309, TUV approved	16A/250V	4.5m	International, locking power cord
B50160F	NEMA 5-15, PSE approved	15A/127V	15 ft	Japan (100V applications)

Table 2-11. Power Cords - ftServer Systems and Peripheral Components to AC Power (Continued)

Marketing ID	Plug Type	Rating	Length	Locale
B50161F	NEMA L6-20	20A/250V	15 ft	North America locking power cord
B50162F	GB1002-1996, CCC approved	10A/250V	4.5m	China
B50173F	NEMA 5-15, BSMI approved	10A/125V	4.5m	Taiwan
B50174-P	L6-20P, PSE approved	15A/250V	15 ft	Japan locking power cord (200V applications)

Table 2-12. Power Cords Between ftServer Systems or Storage Systems and a UPS

Marketing ID	Plug Types	Rating	Length	Locale
B50104F-15	NEMA 5-15 to IEC 60320 C13	16A/120V	15 ft	North America
B50160F	NEMA 5-15 to IEC 60320 C13	15A/127V	15 ft	Japan
B50161F-45M	NEMA L6-20 to IEC 60320 C13	20A/250V	15 ft	North America locking power cord
B50301F-45M	IEC 60320 C14 to IEC 60320 C13	10A/250V	4.5m	International
B50174-P	L6-20P, PSE approved	15A/250V	15 ft	Japan locking power cord (200V applications)

PDU Power Cords

The PDU supplies power to ftServer systems. [Table 2-13](#) lists the available power cords that connect PDUs directly to an AC power source.

[Table 2-14](#) lists the available power cords that connect PDUs to a UPS.

[Table 2-15](#) describes the gray and black power (*jumper*) cables that are provided to connect ftServer systems to PDUs.

Table 2-13. Power Cords to Connect PDUs Directly to AC Power Mains

Marketing ID	Plug Type	Rating	Length	Locale
B50154F	IEC 60320 C19 to IEC 60309	20A/250V	15 ft	International
B50171F	IEC 60320 C19 to NEMA L6-20P	16A/250V	15 ft	North America
B50175F	IEC 60320 C19 to NEMA L6-20P, PSE approved	20A/250V	15 ft	Japan locking power cord

Table 2-14. AC Power Cords to Connect PDUs to a UPS

Marketing ID	Plug Type	Rating	Length	Locale
B50171F	IEC 60320 C19 to NEMA L6-20P	16A/250V	15 ft	North America
B52700F-45M	IEC 60320 C19 to IEC 60320 -C20	20A/250V	4.5m	International
B50175F	IEC 60320 C19 to NEMA L6-20P, PSE approved	20A/250V	15 ft	Japan locking power cord

Table 2-15. System Power (*Jumper*) Cables to Connect ftServer Systems to PDUs

Marketing ID	Plug Type to System	Plug Type to PDU	Rating	Length
B50502F	IEC 60320 C13	IEC 60320 C14	10A/250V	2.0m
B50503F	IEC 60320 C13	IEC 60320 C14	10A/250V	2.0m

Grounding Requirements



WARNING

Incorrect grounding can cause severe personal injury and extensive equipment damage.

The ftServer system obtains its protective earth (PE) ground through the power cord.

See “[Grounding Considerations](#)” on page B-1 for a more complete discussion of ftServer system grounding.

Chapter 3

Space Planning

For information about planning sufficient space for your ftServer system, see:

- [“Room Requirements” on page 3-1](#)
- [“Planning for Cables” on page 3-3](#)

Room Requirements

To ensure that the installation site provides a properly equipped, cooled, and sized environment, make sure that the site:

- Provides clearances for air circulation, opening cabinet doors, removing cabinet panels, and servicing the system from the front and rear.

Locate the front and rear of the system at least 2.5 feet (ft) (0.76 meters (m)) away from walls and other obstructions.

- Maintains reasonable temperature and humidity levels and has a thermometer and humidistat to monitor room temperature and humidity.

See [Chapter 2, “Electrical Power Planning”](#) for detailed information about HVAC planning and [Appendix A, “System Specifications”](#) for detailed information about temperature and humidity requirements.

- Is as free as possible of airborne contamination (particulate and gaseous).



CAUTION

Due to the mission-critical nature of Stratus servers, data centers housing the equipment should follow the guidelines of airborne contamination (particulate and gaseous) as outlined in the ASHRAE (TC) 9.9 documentation. Particulate matter to adhere to ISO 14644-1 Class 8. Gaseous contamination, such as sulfur or chlorine-bearing gases to adhere to ANSI/ISA-71.04-1985 Severity level G1.

Dust buildup in the system can impede air circulation and heat transfer, causing components to become less reliable as the ambient temperature rises.

Fans clogged by dust fail to expel hot air, causing circuit boards to overheat and fail.

Dust on circuit boards raises the temperature, thus reducing the component's mean time between failure (MTBF).

Dust circulating in the room increases the risk of fire within the room by providing potential combustible material within the environment.

Dust contamination on tape devices causes mis-reads and -writes, leading to failure of attempts to back up and restore data.

- Has sufficient floor space for external components.
- Provides a table or desktop for external devices such as a telephone, external monitor, keyboard, and mouse.

Each of these devices requires table or rack space.



CAUTION _____

You **cannot** place a peripheral component on top of a system cabinet.

- Allows the system and peripheral devices to be placed within the room so that power cords and communications cables will reach their respective power receptacles, telephone jacks, and other connection points.
- Provides communications cable connectors or patch panels as needed.
- Provides two electrically separate grounded AC wall outlets, within reach of the power cords from the system or PDUs, and, if used, UPS units. Detachable power cords are 12 ft. (3.65m). If the power cord must be hard-wired, consult an electrician to plan the length of the power cord.
- Provides grounded AC wall outlets for external components that do not connect to a PDU.
- Provides cutouts in the floor for routing cables, if the site has an elevated floor.
- Contains space for future expansion.



CAUTION _____

Do not place the system in an area of high electrostatic discharge. Static electricity may damage components. Do not locate components near transformers or other electromagnetic devices.

See [Appendix A, “System Specifications”](#) and *Stratus ftServer Systems: Peripherals Site Planning Guide (R582)* for the dimensions of system components.

Planning for Cables

To accommodate cables from your system, make sure to provide:

- One or two telephone lines:
 - One telephone line for use when calling for service
 - One telephone line for the ASN modem, if used
- Ethernet jacks, switches, or hubs, as needed
- Two electrically separate grounded AC wall outlets, or a UPS and a wall outlet, within reach of the power cords from the system or PDUs, and additional outlets for any components that do not connect to a PDU
- For optional components, AC wall outlets within reach of the power cords from the components, or use PDUs

Make sure that cables you plan to connect to the system are long enough to reach between the system and external components or connections. For information about specific cables and power cords, see the following:

- [“Power Cord Summary” on page 2-13](#)
- [Chapter 4, “Communications Line Planning”](#)
- [“Monitor Requirements” on page 6-5](#)
- *Stratus ftServer Systems: Peripherals Site Planning Guide (R582)* for information about cable lengths for peripheral components

Chapter 4

Communications Line Planning

Make sure that you plan the locations of your ftServer system and its external components so that all communications and data cables will reach their connection points.

This chapter contains the following sections:

- “Supported Host Bus Adapters” on page 4-2
- “Fibre Channel Connections” on page 4-2
- “Ethernet Cables” on page 4-7
- “iSCSI Connections (VMware-based Systems)” on page 4-9
- “Telephone Line Connections” on page 4-10
- “Site Planning for Systems in an ftGateway Group” on page 4-11

NOTES

1. If you have a unique network requirement, contact Stratus Professional Services. For a list of available services, see <http://www.stratus.com/go/services/professional>.
2. See the *Stratus ftServer Systems: PCI Adapter Guide* (R461) for more information about the adapters Stratus supplies for your ftServer system.

Supported Host Bus Adapters

Table 4-1 summarizes the host bus adapters (HBAs) supported by 2600, 4500, 6300, and 6310 systems.

Table 4-1. HBAs Supported by 2600, 4500, 6300, and 6310 Systems

HBA	For Connections to	Supported on
U106 Eight-Port SAS PCI-Express Adapter	tape drives	Windows- and Linux-based systems
U107 Single-Port 8-Gbps Optical Fibre Channel PCI-Express Adapter	external storage systems	Windows-, Linux-, and VMware-based systems
U539F Single-Port Optical Fibre Channel PCI-Express Adapter	certain external storage system configurations	Linux-based systems
U777F Single-Port Optical Fibre Channel PCI-Express Adapter	certain external storage system configurations	VMware-based systems

You must provide your own cables, with one exception: two 2-meter 50/125 μm (micrometer) OM3 multi-mode fiber (MMF) dual-fiber cables with LC-type connectors (part number AW-B91000-020) are included with each ftScalable Storage G2 system.

See *Stratus ftServer Systems: PCI Adapter Guide (R461)* for information about PCI-Express adapters.

Fibre Channel Connections

ftServer systems support connections to first-generation ftScalable Storage and ftScalable Storage G2, and to EMC CLARiiON and Symmetrix storage systems¹, as well as HP EVA storage systems, models 4000, 6000, or 8000². Optical Fibre-Channel host bus adapters (HBAs) in the CPU-I/O enclosures provide connection points to these storage enclosures.

ftServer systems running ftSSS for the Windows Operating System or ftSSS for the Linux Operating System have the following connection options:

- Directly attach the Fibre Channel cables between one or two ftServer systems and the RAID controller trays of an ftScalable Storage G2 system

¹ Follow EMC's RPQ (Request for Price Quote) process for approval before attaching EMC storage systems to ftServer systems running the Linux operating system.

² HP EVA storage system configurations require ftReady certification.

- Connect the Fibre Channel cables from one or two ftServer systems directly to an EMC storage system (for Windows-based systems only)
- Connect multiple ftServer systems to first-generation ftScalable Storage systems or ftScalable Storage G2 systems through a storage area network (SAN).
- Connect up to six ftServer systems to EMC storage systems through a SAN.

ftServer systems running ftSSS for the Linux Operating System also have the following connection options:

- Directly attach the Fibre Channel cables between an ftServer system and the RAID controller trays of a first-generation ftScalable Storage system.
- Connect an ftServer system to an HP EVA storage system (model 4000, 6000, or 8000) through a SAN.

For ftServer systems running ftSSS for VMware vSphere, the following connection options are available:

- Directly attach the Fibre Channel cables between a single ftServer system and the RAID controller trays of a first-generation ftScalable Storage or ftScalable Storage G2 system.
- Connect multiple ftServer systems to first-generation ftScalable Storage or ftScalable Storage G2 systems through a storage area network (SAN).
- Connect up to six ftServer systems to EMC storage systems through a SAN.

A pair of optical Fibre Channel HBAs provides fault tolerance through the multipath I/O capability of the operating system. The adapters are single-ported, and each member of the pair is installed in a different CPU-I/O enclosure: one in the top enclosure and the other in the bottom enclosure. The *Stratus ftServer Systems: Peripherals Site Planning Guide* (R582) lists the optical Fibre Channel HBAs supported by each operating system.

[Table 4-2](#) lists the optical fiber cables available for connecting U107 PCIe adapters. The cable sets come in blue and yellow, to make it easy to distinguish between members of cable pairs. See the *Stratus ftServer Systems: PCI Adapter Guide* (R461) for information about cables for connecting U539F PCIe adapters and U777F PCIe adapters.

Table 4-2. Optical Fibre Channel Cables

Length	Part number Blue Cables	Part number Yellow Cables
0.98 ft (0.3m)	AW-B91000-003	AW-B91001-003
1.64 ft (0.5m)	AW-B91000-005	AW-B91001-005

Table 4-2. Optical Fibre Channel Cables (Continued)

Length	Part number Blue Cables	Part number Yellow Cables
6.5 ft (2m)	AW-B91000-020	AW-B91001-020
32.8 ft (10m)	AW-B91000-100	AW-B91001-100
98.4 ft (30m)	AW-B91000-300	AW-B91001-300

For detailed instructions about making the Fibre Channel connections, see one of the following:

- The *ftScalable Storage: Getting Started Guide (R601)* or *ftScalable Storage G2: Getting Started Guide (R651)*
- The documentation for your EMC storage system

The following figures show Fibre Channel connections, in both direct-attach (DAS) and storage-area-network (SAN) configurations, from ftServer systems to ftScalable Storage G2 and first-generation ftScalable Storage systems. (Connections to EMC storage systems through a SAN are similar.)

Figure 4-1. Fibre Channel Connections to an ftScalable Storage G2 System in a DAS Configuration

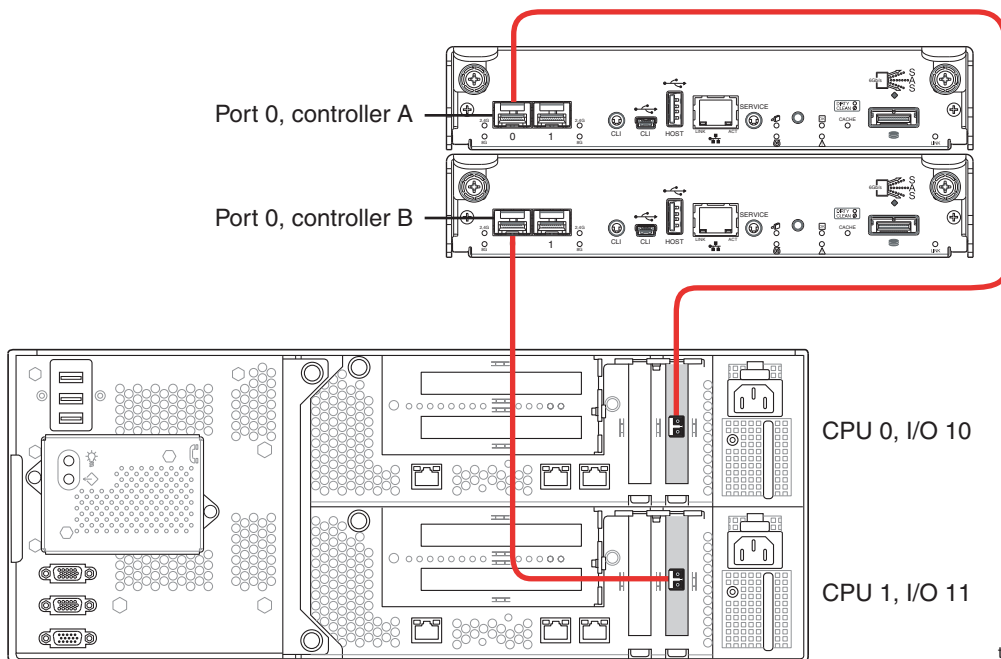

taz095a

Figure 4-2. Fibre Channel Connections to a First-Generation ftScalable Storage System in a DAS Configuration*

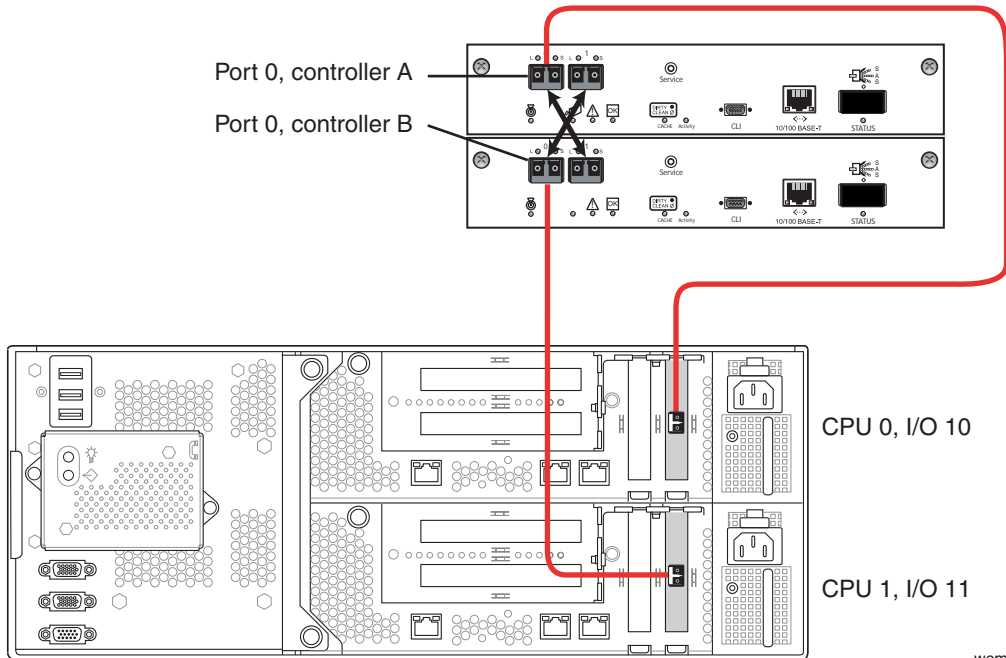

wom041a

* Crossed arrows at the controller ports indicate an internal host port interconnect setting of Interconnected.

Figure 4-3. Fibre Channel Connections to an ftScalable Storage G2 or First-Generation ftScalable Storage System in a SAN Configuration

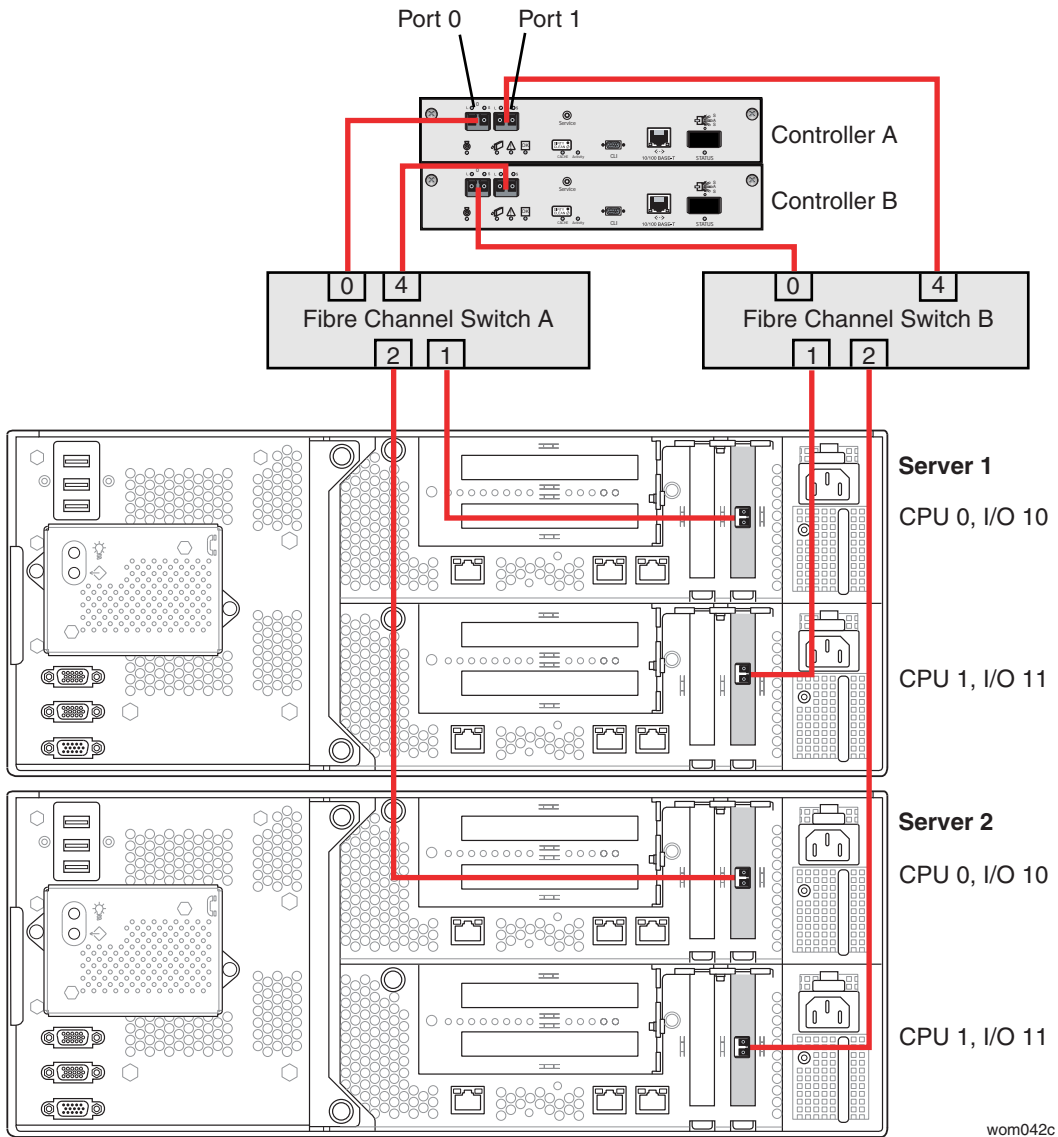

wom042c

Ethernet Cables

In addition to the Ethernet cables listed in this section, you must also plan to provide network connection points. Consider providing a network connection with Internet access for each of the VTMs to allow you and, if authorized, the CAC or your authorized Stratus service representative to access the VTMs' Web interface to operate the system and diagnose problems remotely. If available, this mode of accessing the VTMs is faster and more reliable than dialup through the ASN modem.



WARNING

Make sure network cables can be routed out of the way of foot traffic.

You will need Ethernet cables for the following connections:

- From two or four embedded Ethernet ports on the system and Ethernet ports on U104, U105, and U108 PCIe adapters to network connection points

NOTE

Two Ethernet ports are typically paired and teamed in software for fault tolerance. Each member of the pair requires an Ethernet cable.

- From each first-generation ftScalable Storage or ftScalable Storage G2 RAID controller tray, if present, to a network connection point, for Web management and monitoring of ftScalable Storage systems
- From a management PC to a network connection point, for Web management of ftScalable Storage systems

The same network must provide access to the RAID controllers on the first-generation ftScalable Storage or ftScalable Storage G2 RAID controller tray from the PC.

[Table 4-3](#) describes the cables you must supply for network connectivity. Be sure to provide cables of sufficient length for the distance between the system and a wall jack or hub.

Table 4-3. Customer-Supplied Ethernet Cables

Component	Quantity	Marketing ID/Cable Length	Cable Type
VTM Ethernet port	2	N/A. You must supply these cables.	24 AWG Unshielded Twisted Pair (UTP) EIA/TIA-Verified, Category-3 or Category-5 wire, with RJ-45 modular connectors terminated with pair-wiring adhering to the EIA/TIA 568-A or EIA/TIA 568-B standard.
System Ethernet port	2 or 4		
U105 Dual-Port Copper 10/100/1000 Base-T Ethernet PCI-Express Adapter (gigabit copper adapter for servers)	1 for each port, typically teamed for fault tolerance	The maximum allowable distance from these ports to a switch or a hub is 328 ft (100m).	For connections to an Ethernet hub or switch, provide a straight-through cable. For 100- or 1000-Mbps (fast Ethernet) operation, provide full-duplex, or Category-5 Ethernet cables.
U104 Dual-Port Fiber Gigabit Ethernet PCI-Express Adapter (gigabit fiber-optic adapter for servers)	1 for each port, typically teamed for fault tolerance	N/A. You must supply these cables. The maximum distance between the U104 PCIe adapter and a switch is 902 ft (275m).	Multimode, 62.5- or 50-micron, DUAL fiber cable with LC-type connectors to the PCIe adapter, and connectors on the other end that are compatible with your site network switch.
U108 Single-Port Fiber 10-Gigabit Ethernet PCI-Express Adapter	1, typically teamed for fault tolerance	N/A. You must supply this cable. With the specified type of cable and a 10-Gigabit link established, the maximum distance between the PCI adapter and an Ethernet hub or a switch is 984 ft (300 m).	Multi-mode fiber (MMF), 50/125 μ m dual-fiber cable rated with the OM3 performance code, with LC-type connectors to the PCIe adapter, and connectors on the other end that are compatible with your site network switch.

Table 4-3. Customer-Supplied Ethernet Cables (Continued)

Component	Quantity	Marketing ID/Cable Length	Cable Type
ftScalable Storage RAID controller tray [†]	3: two for each controller tray and one to a management PC	N/A. You must supply these cables.	<p>24 AWG Unshielded Twisted Pair (UTP) EIA/TIA-Verified, Category-3 or Category-5 wire, with RJ-45 modular connectors terminated with pair-wiring adhering to the EIA/TIA 568-A or EIA/TIA 568-B standard.</p> <p>For connections to an Ethernet hub or switch, provide a straight-through cable.</p> <p>For 100-Mbps (fast Ethernet) operation, provide full-duplex, or Category-5 Ethernet cables.</p>

[†] First-generation ftScalable Storage and ftScalable Storage G2 systems are optional. If you connect an ftServer system running VMware ESX software to an iSCSI or EMC storage system, consider its Ethernet network requirements in your site planning.

iSCSI Connections (VMware-based Systems)

ftServer systems running ftSSS for VMware vSphere that boot from internal SAS disks support the use of iSCSI external storage enclosures. These systems only support software iSCSI in conjunction with standard network adapters. Hardware iSCSI HBAs are not supported.

Stratus does not sell iSCSI storage systems. Contact your account representative for information about iSCSI storage systems qualified for use with ftServer systems. See the VMware documentation for information about how to configure and manage an iSCSI storage system.

NOTES _____

1. See the *Stratus ftServer Systems: PCI Adapter Guide* (R461) for additional information about supported Ethernet adapters.
2. Ensure that your ftServer system provides adequate bandwidth for your iSCSI storage requirements.

Telephone Line Connections

The system requires up to two telephone cables, and related connection points:

- One telephone line for use when calling for service
- One analog telephone line to connect the ASN modem, if used, to a telephone connection point

A 7-ft (2.13m) telephone cable (minimum 26 AWG phone cord) is shipped with the modem assembly.³

NOTE

A dedicated phone line provides the most reliable service for ASN connections. ASN calls routed through a PBX might be slow due to the load on the PBX, or might not complete successfully because the calls can become disconnected. If you must use a PBX, do not route the telephone extension through a switchboard; instead, provide a direct-dial analog number.

- Always use telephone cable that is 26 AWG or greater and is UL approved.

If no modem is installed, a second telephone line is not necessary. A modem is not necessary in the following situations:

- If your system will connect to a network with Internet access, you may choose to use the Internet to send alarms to the ASN and allow the CAC or your authorized Stratus service representative to connect to your system over the Internet for troubleshooting.
- If you implement ftGateway groups, only one system in the group requires a modem. See [“Site Planning for Systems in an ftGateway Group”](#) for more information.

Telephone Line Connections in Australia and New Zealand

The telephone used when calling for service shall comply with the following local regulatory requirements:

- Australia: The telephone shall have an A-tick label
- New Zealand: The telephone shall have a Telepermit

³ The telephone cable is not shipped with orders destined for the Republic of Korea.

If an ASN modem is installed, that model shall comply with the following local regulatory requirements:

- Australia: The modem shall have an A-tick label
- New Zealand: The modem shall have a Telepermit

Site Planning for Systems in an ftGateway Group

Multiple ftServer systems at a site can share a single telephone connection to the ASN by implementing an *ftGateway group*. Unless VTMs are installed in each system, the systems in the group must be connected to a single physical Ethernet subnetwork.

One system acts as a *gateway* for ASN connectivity. This gateway system (or *ftGateway master*) requires an analog telephone line that connects to the modem. Other systems in the ftGateway group, called *ftGateway slaves*, connect to the gateway system over the network. In this case, Ethernet connections are required for each system, but only two analog telephone lines for each ftGateway group are required.

NOTES _____

1. ftServer 2600, 4500, 6300, and 6310 systems running the Windows operating system can only be ftGateway slaves, not masters.
2. ftServer 2600, 4500, 6300, and 6310 ftGateway slave systems require an ftGateway master system running Windows ftSSS Release 5.3.
3. ftServer 2600, 4500, 6300, and 6310 systems running Linux Releases ftSSS 7.0.4 and later or any release of VMware ESX do not support ftGateway groups.

Members of an ftGateway group:

- Are limited to a maximum of 20 ftServer systems.
- Must connect to the same subnetwork through embedded system Ethernet ports, PCI Ethernet adapter ports, or VTM Ethernet ports. An ftGateway group can consist of one of the following:
 - Slave systems that run the Windows operating system with no remote management adapter in a group with an ftGateway system that has VTMs
 - Slave systems that have VTMs in a group with an ftGateway system that has VTMs

NOTES

1. You cannot mix VTMs and ftServer Access Adapters in the same ftGateway group. (ftServer Access Adapters are system management adapters used in earlier models of ftServer systems.)
2. Make sure that only layer-1 and layer-2 devices separate the gateway and slave systems. During a connection, the gateway system assigns the slave system a temporary IP address from an IP address range reserved by Stratus and uses that address for all traffic.

Chapter 5

Rack Configuration Planning

For information about planning a rack configuration, see:

- [“Using PDUs” on page 5-1](#)
- [“Determining PDU Requirements” on page 5-2](#)
- [“Example of PDU Usage Calculation” on page 5-4](#)

Using PDUs

Server systems have two power receptacles. Correspondingly, two power distribution units (PDUs) provide power to the receptacles.

Use of PDUs is optional unless you have a support agreement with Stratus. If you do have a support agreement with Stratus, use pairs of PDUs to provide AC power to systems and components in a cabinet **if six or more power cords would otherwise exit from the cabinet.**

The A-side (top) PDU provides power to:

- The A-side of each system
- A rack-mounted LCD monitor unit
- A storage enclosure
- Any rack-mounted tape drives

The B-side (bottom) PDU provides power to the other side of each system and to the second side of a storage enclosure.

Because the A-side PDU always uses at least as many power cords and consumes at least as much power as the B-side PDU, plan the cabinet configuration so that the A-side PDU can support the configuration.

NOTES

1. Connect each PDU to a separate AC power source.
2. Install a maximum of two pairs of PDUs in a rack.

Use the information in “[Determining PDU Requirements](#)” on page 5-2 to plan the rack configuration for your ftServer system. “[Example of PDU Usage Calculation](#)” on page 5-4 shows how to use the information you gather for planning the rack configuration.

Determining PDU Requirements

Using the nominal voltage rating of the power receptacle at your site and the total wattage of the components that will draw power from the A-side PDU, complete the information in Tables 5-1 and 5-2. This information will help you determine the current that the ftServer systems and rack-mounted components will draw and whether you need a second pair of PDUs.

To complete Table 5-1

1. Obtain the voltage available at your location. Consult a facilities manager at your site to make sure you know the correct voltage.
2. For each type of component you plan to place in the rack, calculate the required current, as follows: Divide the wattage of the element, listed in the Watts column of Table 5-1, by the voltage available at your site. Multiply the result by 1.25 and enter the value in the **Current** column.

Table 5-1. Current and Rack-Space Requirements

Component	Watts	÷	Site Voltage†	x 1.25 =	Current (A)	Rack Space
ftServer system	700	÷		x 1.25 =		4U
1U LCD monitor unit‡		÷		x 1.25 =		1U
Tape-drive enclosure§		÷		x 1.25 =		
Disk-storage enclosure§		÷		x 1.25 =		

† PDU input voltage is 200-240 VAC.

‡ See the *Stratus ftServer Systems: Peripherals Site Planning Guide* (R582) for the wattage and rack requirements of your monitor and disk-storage solutions.

§ See your tape-drive documentation for the wattage and rack requirements of your tape drive.

To complete Table 5-2

1. In column 1, write the names of each system or component in the rack. If you have more than one system, use a row for each system.
2. In column 2, write the cumulative number of rack units (Us): Add the number of Us (see Table 5-1) for the component to the value in the space above and write the result.
3. In column 3, write the cumulative number of outlets required. For each component, add 1 to the value in the space above and write the result.
4. In column 4, write the cumulative current required. For each component, add the current for the component, which you entered in Table 5-1, to the value in the space above and write the result.

You need another pair of PDUs if the cumulative number of outlets exceeds 8 or if the cumulative current exceeds 15A. Use the information in column 2 to plan the size and number of racks required.

Table 5-2. Calculating A-Side PDU and Rack-Space Requirements

1. Component	2. Cumulative Space Used	3. Cumulative Number of Outlets	4. Cumulative Current (A)
PDU Pair	2U	0	0.00

Example of PDU Usage Calculation

Table 5-3 shows how to use the information from Table 5-1 to calculate the required rack space and the current when the PDU is connected to a NEMA L6-20R receptacle in the United States, with a voltage of 208V.

Table 5-3. Example: Current and Rack-Space Requirements (208 volts)

Component	Watts	÷	Site Voltage	x 1.25 =	Current (A)	Rack Space
ftServer system	700	÷	208	x 1.25 =	4.21	4U
1U LCD monitor unit	54	÷	208	x 1.25 =	0.32	1U
Tape drive (typical)	80	÷	208	x 1.25 =	0.48	2U
ftScalable Storage G2 system	436	÷	208	x 1.25 =	2.62	2U

Table 5-4 and the explanation that follows show how to use the information from Table 5-3 to determine when you need to buy an additional pair of PDUs or calculate the size and number of cabinets you need.

Table 5-4. Example: Calculating A-Side PDU and Rack-Space Requirements

1. Component	2. Cumulative Space Used (U)	3. Cumulative Number of A-Side Outlets	4. Cumulative Current (A)
PDU pair	2	0	0.00
ftServer system	6	1	4.21
1U LCD monitor unit	7	2	4.53
Tape drive (typical)	9	3	5.01
ftScalable Storage G2 system	11	4	7.63
ftServer system	15	5	11.84
PDU pair	2	0	0
ftServer system	6	1	4.21
ftServer system	10	2	8.42

In the calculations in Table 5-4, components were added one by one, calculating:

- The total current demanded by the components
- The total space used in the rack
- The total number of outlets required

In this example, two PDUs can provide enough current for two ftServer 2600, 4500, 6300, or 6310 systems, the LCD monitor unit, one tape drive (typical), and one ftScalable Storage G2 system. This set of components consumes 11.84 amperes; adding another ftServer system would increase the consumption to 16.05 amperes, which exceeds the 15 amperes limit for the PDUs. The configuration also utilizes 5 outlets in the A-side PDU and 15U of rack space.

To add any more components, you require another pair of PDUs.

For information about planning a rack configuration, see:

- [“Using PDUs” on page 5-1](#)
- [“Determining PDU Requirements” on page 5-2](#)
- [“Example of PDU Usage Calculation” on page 5-4](#)

Chapter 6

Cabinet and Monitor Requirements

For requirements related to providing your own cabinet and monitor, see:

- [“Cabinet Requirements” on page 6-1](#)
- [“Monitor Requirements” on page 6-5](#)

Cabinet Requirements

If you are providing your own cabinet for an ftServer system, make sure the cabinet contains a rack that is 19 inches (in.) wide and that meets the Electronic Industries Association (EIA) 310-D Section 1 standard.

In general, consider the following factors during your site planning for systems in cabinets:

- **Elevated Operating Ambient Temperature**—If installed in a closed or multi-unit rack assembly, the operating ambient temperature of the rack environment may be greater than room ambient. Therefore, consideration should be given to installing the equipment in an environment compatible with the maximum ambient temperature (T_{ma}) specified by the manufacturer.
- **Reduced Air Flow**—Installation of the equipment in a rack should be such that the amount of air flow required for safe operation of the equipment is not compromised.
- **Mechanical Loading**—Mounting of the equipment in the rack should be such that a hazardous condition is not achieved due to uneven mechanical loading.
- **Circuit Overloading**—Consideration should be given to the connection of the equipment to the supply circuit and the effect that overloading of the circuits might have on overcurrent protection and supply wiring. Appropriate consideration of equipment nameplate ratings should be used when addressing this concern.
- **Reliable Earthing**—Reliable earthing of rack-mounted equipment should be maintained. Particular attention should be given to supply connections other than direct connections to the branch circuit (for example, use of power strips).

Make sure that the cabinet meets the following requirements:

- The cabinet can support the weight of all the components you plan to install in it. [Appendix A](#) and the *Stratus ftServer Systems: Peripherals Site Planning Guide* (R582) provides the weights of components supplied by Stratus.
- The cabinet contains two front and two rear vertical EIA rails, one in each corner of the cabinet, that have the **universal** square-hole pattern as defined in the EIA 310-D Section 1 specification.
- The front vertical rails extend at least 0.5 in. (1.27 centimeters (cm)) beyond the inside edge of the accessory leg, if present, to allow the mounting rails to be fitted. See [Figure 6-1](#).
- The distance between the front vertical rails and the inside of the front door is at least 3.0 in. (7.62 cm).
- The distance between the rear of the system chassis and the inside of the rear door is at least 6.0 in. (15.24 cm).
- The distance between the front and rear vertical rails is between 24.5 in. and 30 in. (62.23 cm and 76.20 cm, respectively).
- The vertical mounting rails have a 0.345" or 0.375" square pattern, with a thickness between 0.063" - 0.105", to accept 10-32 cage nuts and mounting hardware.
- The vertical mounting rails are plated, or some other method is used to ensure continuity for grounding between installed equipment.
- Cable-management brackets are provided to support and constrain data and power cords so that the cables do not interfere with air flow out of the rear of the enclosures, and so that the connectors do not disconnect or break.
- To prevent stray voltages, all components are grounded together through the vertical mounting rails to the cabinet frame, and then to local building ground. To ensure signal quality, use a grounding cable for local building ground.
- There is a plan for maintaining cables and wires to the cabinet by either running them under the floor or placing them overhead in an overhead cable tray.
- Air flows through the cabinet from front to back.
- Air does not recirculate within the cabinet.
- Filler panels cover any unused rack space to prevent air recirculation.
- Blockers are installed between the vertical mounting rails and the side panels at the rear of the cabinet.
- Vents are evenly distributed on the front and rear doors and make up at least 69% of the surface area.

NOTE _____

If your cabinet does not have vented front and rear doors, you can remove the doors from the cabinet while your ftServer system is operating.

- The final installation conforms to all emission, immunity, safety, and other applicable regulations.

Figure 6-1 shows the required rail clearance between the front vertical rails and the inside edge of an accessory leg.

Figure 6-1. Rail Clearance

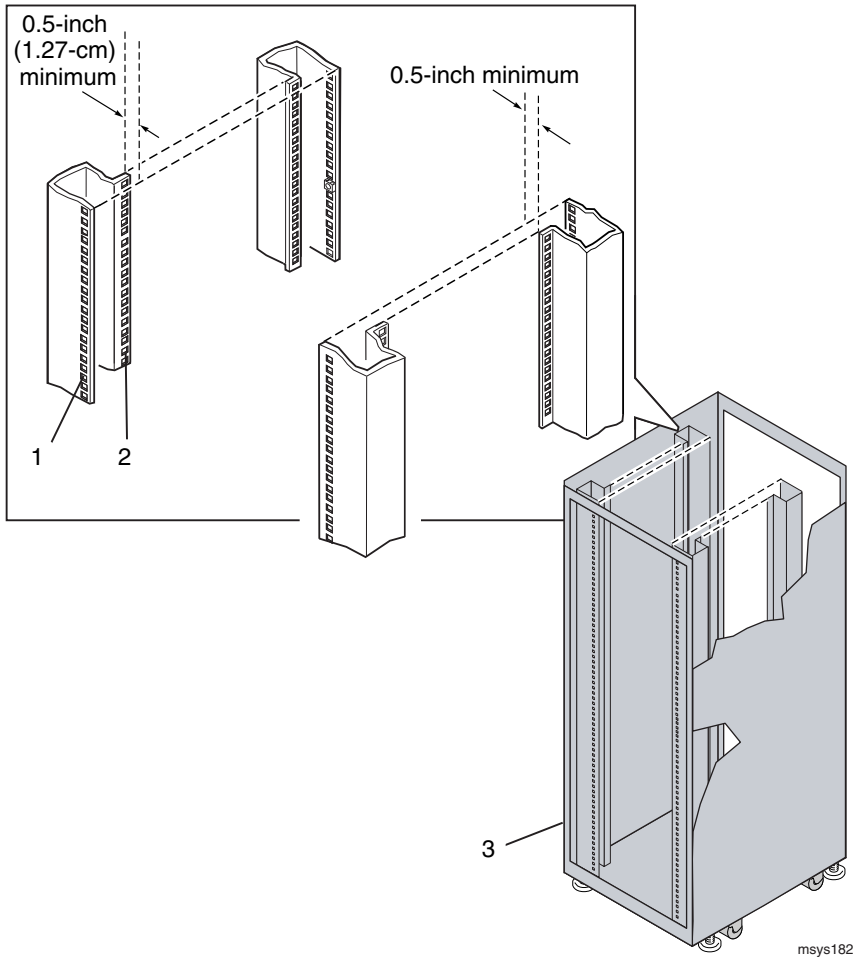

- 1 Front vertical EIA rail
- 2 Accessory leg
- 3 Front of cabinet

Monitor Requirements

If you are using a monitor that is not supplied by Stratus, make sure that:

- The monitor accepts universal 100–240 volts AC (VAC), 50/60 Hertz (Hz) power.
- The VGA cable has a 15-pin D-sub connector.
- The power cord for the monitor is long enough to reach the power source.
- The plug type on the power cord is compatible with the external power source at the site.

Appendix A

System Specifications

For system specifications, see:

- [“System Specifications” on page A-1](#)
- [“PCI Adapter Specifications” on page A-7](#)
- [“AAP87600 PDU Specifications” on page A-8](#)

NOTES

1. The system temperature and humidity requirements defined in Tables [A-2](#) are the **minimum** requirements the site must provide.
2. The temperature and humidity requirements for optional components are provided in the *Stratus ftServer Systems: Peripherals Site Planning Guide (R582)*.

System Specifications

The following figures show front and rear views of the systems.

- [Figure A-1](#) shows the front of an ftServer 2600, 4500, 6300, or 6310 system, mounted in a rack with its bezel pulled forward.
- [Figure A-2](#) shows the rear of a rack-mountable ftServer 2600, 4500, 6300, or 6310 system, specifying the locations of the connectors at the rear of the system.

[Table A-1](#) lists the dimensions of the system cabinets supplied by Stratus. [Table A-2](#) lists the specifications for each ftServer CPU-I/O enclosure, the front panel, and the backplane assembly. [Table A-4](#) lists the specifications of the PDU. See the *Stratus ftServer Systems: Peripherals Site Planning Guide (R582)* for the specifications of other components.

Figure A-1. ftServer 2600, 4500, 6300, or 6310 System: CPU-I/O Enclosures: Front View

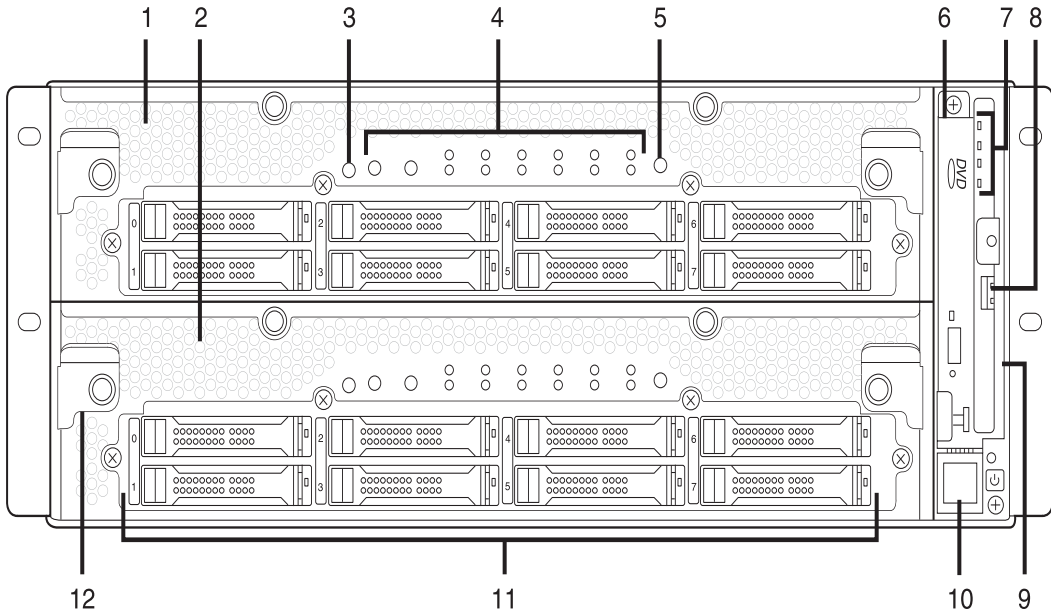

dco001b

- | | | | |
|---|---------------------------------------|----|--|
| 1 | CPU 0, I/O 10 | 7 | Front panel LEDs |
| 2 | CPU 1, I/O 11 | 8 | USB port |
| 3 | CPU ID button (magnifying glass icon) | 9 | Front panel |
| 4 | System LEDs | 10 | Power button |
| 5 | NMI (dump) button | 11 | Internal disk drives (16) or disk drive blanks |
| 6 | DVD drive | 12 | Release levers (4) |

Figure A-2. ftServer 2600, 4500, 6300, or 6310 System: Rear View

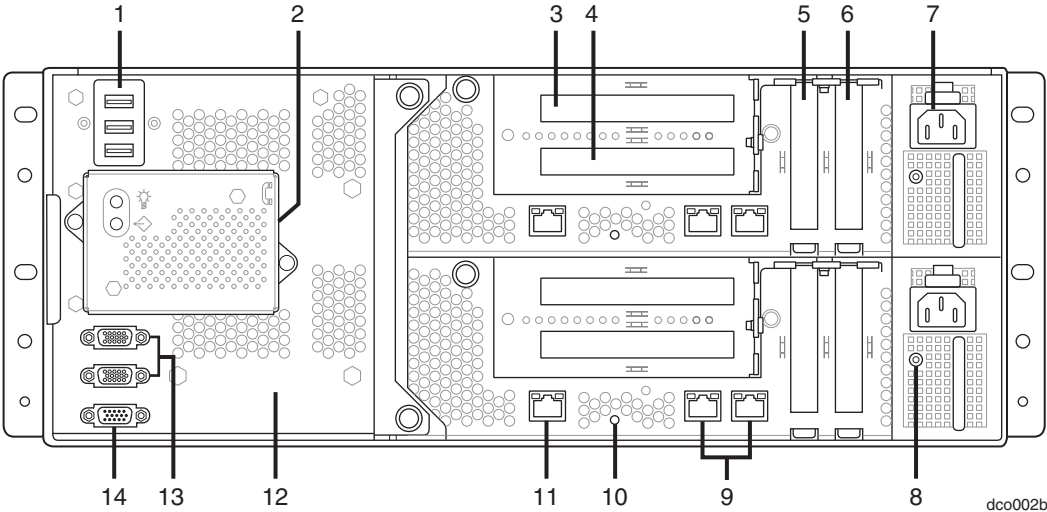

- 1 USB ports (3)
- 2 Modem and telephone port
- 3 PCI adapter slot 3 (PCIe full-height). Slot 3 not available on ftServer 2600 systems.
- 4 PCI adapter slot 4 (PCIe full-height). Slot 4 not available on ftServer 2600 systems.
- 5 PCI adapter slot 1 (PCIe, low profile)
- 6 PCI adapter slot 2 (PCIe, low profile)
- 7 Power receptacles (2)
- 8 Power supply LEDs (2)
- 9 Embedded 10/100/1000-Mbps Ethernet ports (4)
- 10 CPU-I/O enclosure blue identification LEDs (2)
- 11 VTM Ethernet ports (2)
- 12 System backplane
- 13 Serial (COM) ports (2)
- 14 VGA (monitor) port

Table A-1. Cabinet Dimensions

24U Shipping Container	
Height (including pallet)	56 in. (1.42m)
Width	41 in. (1.04m)
Depth	53 in. (1.35m)
38U Shipping Container	
Height (including pallet)	80 in. (2.03m)
Width	41 in. (1.04m)
Depth	53 in. (1.35m)
24U Cabinet	
Height (including casters)	49.5 in. (1.26m)
Width	27.6 in. (70 cm)
Depth	41 in. (1.04m)
Weight, empty	280 lb (127 kg)
Weight, empty with pallet and shipping container	436 lb (197.8 kg)
Weight capacity (payload)	1500 lb (559.9 kg)
38U Cabinet	
Height (including casters)	74 in. (1.9m)
Width	27.5 in. (70 cm)
Depth	41 in. (1.04m)
Weight, empty (with front and rear doors)	350 lb (157.7 kg)
Weight, empty with pallet and shipping container	512 lb (232.2 kg)
Weight capacity (payload)	1500 lb (559.9 kg)

Table A-2. ftServer 2600, 4500, 6300, or 6310 System: CPU-I/O Enclosure Specifications

Power	
Input power	700W for each enclosure (1400W total)
Nominal input voltage	100-127 or 200-240 volts; 50/60 Hz
Power Factor	0.98
VA	720 (240V x 3A) 700 (100V x 7A)
Protective earth ground current	3.5 mA maximum for each AC power cord
Physical Dimensions	
Height	7.0 in. (17.78 cm; 4U)
Width	17.50 in. (44.45 cm)
Depth	29.27 in. (74.34 cm), with modem, excluding rail and bezel
Weight (fully-loaded, with 2 processors, 12 DIMMS, and 8 disks per CPU-I/O enclosure)	System (2 CPU-I/O enclosures, shelf unit, front panel, backplane, and bezel): 120 lb (54 kg) Mounting brackets: 3 lb (2 kg)
Environmental	
Operating temperature	41° F to 95° F (5° C to 35° C) For every 800 ft (243.8 m) above 2000 ft (609.6 m), lower the maximum operating temperature by 1° C.
Storage temperature	-38° F to 140° F (-40° C to 60° C), vented
Operating altitude	0 ft to 10,000 ft (0m to 3,048m)
Maximum rate of temperature change during operation	12° C per hour
Relative humidity during operation	10% to 80% (noncondensing)
Relative humidity during storage	5% to 95% (noncondensing)
Heat dissipation, each system (both enclosures)	4774 BTUs per hour

Table A-2. ftServer 2600, 4500, 6300, or 6310 System: CPU-I/O Enclosure Specifications (Continued)

Air cleanliness	Meets ISO 14644-1 class 8 standards
Features	
Processors	<p>ftServer 2600: One Intel® Xeon® Quad-Core 2.0 GHz processor in each CPU-I/O enclosure</p> <p>ftServer 4500: One or two Intel Xeon Quad-Core 2.0 GHz processors in each CPU-I/O enclosure</p> <p>ftServer 6300: Two Intel Xeon Quad-Core 2.93 GHz processors in each CPU-I/O enclosure</p> <p>ftServer 6310: Two Intel Xeon Hex-Core 2.93 GHz processors in each CPU-I/O enclosure</p>
Memory	12 physical, fully-buffered (FB) DDR3 inline memory module (DIMM) slots in each CPU-I/O enclosure. All 12 slots are usable in dual processor systems. Only 6 slots are usable in single processor systems.
Ports	<p>Two 10/100/1000-Mbps Ethernet ports in each CPU-I/O enclosure</p> <p>Two AC power connectors, one VGA port, two serial ports, and four USB ports[†] (three on the system backplane and one on the front panel)</p>
PCIe slots (standard)	<p>Two low-profile PCI-Express slots standard on each CPU-I/O enclosure</p> <ul style="list-style-type: none"> • See “PCI Adapter Specifications” for details
Additional PCI slots (optional for ftServer 4500, 6300, and 6310 systems)	<p>Each CPU-I/O enclosure supports one optional riser:</p> <ul style="list-style-type: none"> • Optional PCIe riser supports two full-height-capable PCIe slots <p>See “PCI Adapter Specifications” for details</p>
BMC	One advanced system management module (Baseboard Management Controller, or BMC) embedded in each CPU-I/O enclosure with one 10/100-Mbps Ethernet port dedicated to the BMC in each CPU-I/O enclosure. BMCs include embedded Virtual Technician Module (VTM) functionality.
Disk drives	Up to eight Serial Attached SCSI (SAS) disks per CPU-I/O enclosure [†]
DVD+/-R drive [‡]	In the front panel, one drive that reads from CDs and DVDs.

[†] Internal data disk drives are not supported for Linux-based systems that boot from a storage area network (SAN).

[‡] ftServer Systems running VMware ESX support the DVD drive and other USB devices only during the initial software installation process and maintenance periods. For more information about explicitly enabling them after installation, see the *Stratus ftServer System Administrator's Guide for VMware vSphere (R002E)*.

PCI Adapter Specifications

Two PCIe slots are standard on each CPU-I/O enclosure motherboard. Optionally, you can add a PCIe riser on an ftServer 4500, 6300, or 6310 system for two additional slots per enclosure. [Table A-3](#) lists the power and length specifications for PCI adapters.

Table A-3. PCI Adapter Specifications

Power	
PCI slot rating	10W maximum per PCI slot
Physical Dimensions	
CPU-I/O enclosure motherboard	Two low-profile PCIe slots 6.6 in (167.75 mm) maximum adapter length
Optional PCIe riser (not available on ftServer 2600 systems).	Two full-height-capable PCIe slots Top riser slot (PCI 3): 7.7 in. (195.94 mm) maximum adapter length Lower riser slot (PCI 4): 6.6 in. (167.75 mm) maximum adapter length

Use only Stratus-approved PCI adapters in your Stratus system. Before approving an adapter, Stratus thoroughly tests it to make sure that it interacts properly with Stratus systems, including failover to a duplexed partner if an active adapter or CPU-I/O enclosure fails or is removed from service. Customers who have attempted to use inadequately tested PCI adapters in their systems have frequently experienced problems that proved difficult to isolate and diagnose and resulted in delayed projects.

Stratus provides ftReady third-party PCI adapter testing and driver hardening services. To find out more about these professional service offerings, please contact your local Stratus sales or service representative.

You should thoroughly test any new PCI adapter, including adapters sold or approved by Stratus, with your applications in a test environment before using it in a production environment.

All Stratus-approved PCI adapters are submitted for Electromagnetic Interference (EMI) and safety compliance. Other adapters will not have EMI and safety approvals for use in an ftServer system.

AAP87600 PDU Specifications

A power distribution unit (PDU) optionally supplies power to rack-mounted ftServer systems and optional rack-mountable components. [Figure A-3](#) shows the AAP87600 PDU.

Figure A-3. AAP87600 PDU

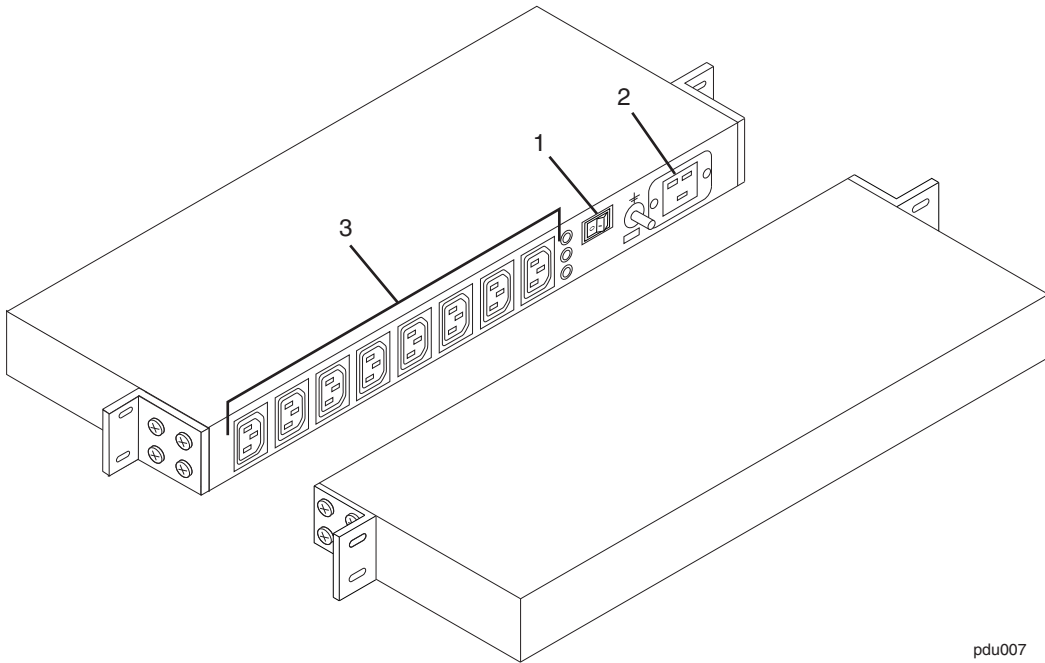

pdu007

- 1 Circuit breaker switch
- 2 AC input receptacle
- 3 AC outlet receptacles

Table A-4 lists the specifications for the AAP87600 PDUs.

Table A-4. AAP87600 PDU: Specifications

Power	
Input power	N/A
Nominal input voltage; frequency	200–240 VAC; 50/60 Hz
Physical Dimensions	
Height	1.75 in. (4.45 cm)
Width	19.1 in. (48.51 cm)
Depth	6.75 in. (17.15 cm)
Environmental	
Operating temperature during operation	41° F to 95° F (5° C to 35° C) For every 800 ft (243.8m) above 2000 ft (609.6m), lower the maximum operating temperature (95° F (35° C)) by 1.8° F (1° C).
Maximum rate of temperature change during operation	12° C per hour or 0.2° C per minute
Relative humidity during operation	10% to 80% (noncondensing)
Storage temperature to 40,000 ft (12.2 km)	-38° F to 140° F (-40° C to 60° C)
Relative humidity during storage	5% to 95% (noncondensing)

Appendix B

Electrical Circuit and Wiring Information

For electrical circuit and wiring information that you need to provide to the contractor and/or facilities personnel responsible for wiring the power at the system installation site, see:

- [“Fault Protection Requirements” on page B-1](#)
- [“Grounding Considerations” on page B-1](#)
- [“Circuit Wiring Diagrams” on page B-2](#)
- [“Electrical Power Connectors” on page B-9](#)

Fault Protection Requirements

Each enclosure in ftServer systems contains internal fault/overload current protection. However, the system relies on the power distribution system at your site for protection against potential faults in the power cords and the wiring in the system base.

System and PDU power cords must not be connected to a branch circuit greater than 20A.

Grounding Considerations

The system obtains an earth reference ground through the power cords attached to the system. Similarly, each peripheral device connected to the system obtains ground through its power cord. You **must** ensure that a high-integrity safety-ground conductor is installed as part of the wiring system (in accordance with U.S. national electric code NFPA 70 or the equivalent). The international safety standard (EN60950) for electronic data processing (EDP) equipment also requires a ground conductor, but calls it a protective earth (PE) ground.

Depending upon local conditions, ground potentials may differ between the system base and any peripheral devices connected to the system base. All grounds in the system **must** return to the same reference point in the power distribution system, as close as possible to **zero (0) volt potential** relative to earth reference ground. Earth reference ground is typically a metal stake in the ground to which the ground conductors from one or more buildings are attached.

As shown in [Figure B-1](#), a *star ground* is often used to obtain the same earth reference ground. Each earth reference ground, such as the system base ground, is returned separately to a common point where a zero-volt (0V) earth ground exists. The star ground ensures that all equipment is at the same potential and that no noise or safety problems associated with an unpredictable or uncharacterized grounding system will occur.

Figure B-1. Star Ground Example

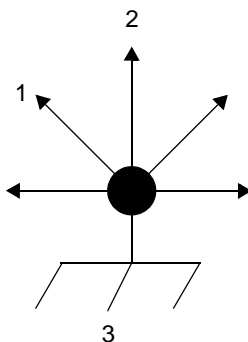

- 1 To monitor
- 2 To ftServer system
- 3 Earth reference ground (0V)

Circuit Wiring Diagrams

The following circuit wiring diagrams show how the hot, ground, and/or neutral AC signals should be connected to the power input plugs of the system and optional components:

- [Figure B-4](#) illustrates a single-phase 120V AC circuit connection.
- [Figure B-5](#) illustrates a single-phase 240V AC circuit connection.
- [Figure B-6](#) illustrates a split-phase 120/240V AC circuit connection.
- [Figure B-7](#) illustrates a three-phase 208V AC, Y-, or Δ -source circuit connection, phase-to-phase.
- [Figure B-8](#) illustrates a three-phase 380V AC, Y-, or Δ -source circuit connection, phase-to-neutral.

In the following diagrams, the power inputs for ftServer 2600, 4500, 6300, and 6310 systems are labeled X and Y, as shown in [Figure B-2](#) and [Figure B-3](#), to eliminate any ambiguities in the nomenclature. For single-phase applications, the X input is

connected to the L (Line) *hot* input, and the Y input is connected to the N (Neutral) input. However, for split-phase or three-phase applications, the X and Y inputs are connected to L1, L2, or L3 (separate lines). Therefore, for split-phase or three-phase applications, both X and Y can be electrically hot with respect to the system base (earth reference ground). [Figure B-2](#) shows the physical locations of the X and Y inputs on the PDU, and [Figure B-3](#) shows them on the system enclosure.

Figure B-2. PDU Power Input Labeling

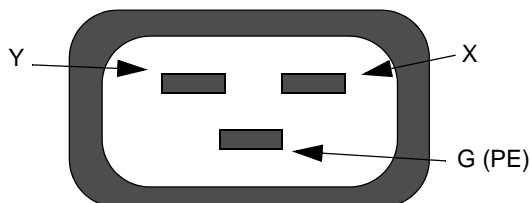

PDU power input A or B (Face View)

Figure B-3. ftServer Enclosure Power Input Labeling

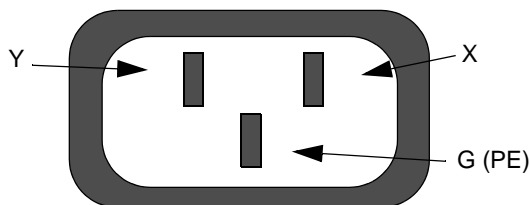

ftServer Enclosure power input A or B (Face View)

Figure B-4 shows a single-phase 120V AC circuit connection. Note that this application requires a single-pole circuit breaker.

Figure B-4. Single-Phase 120V AC Circuit Connection

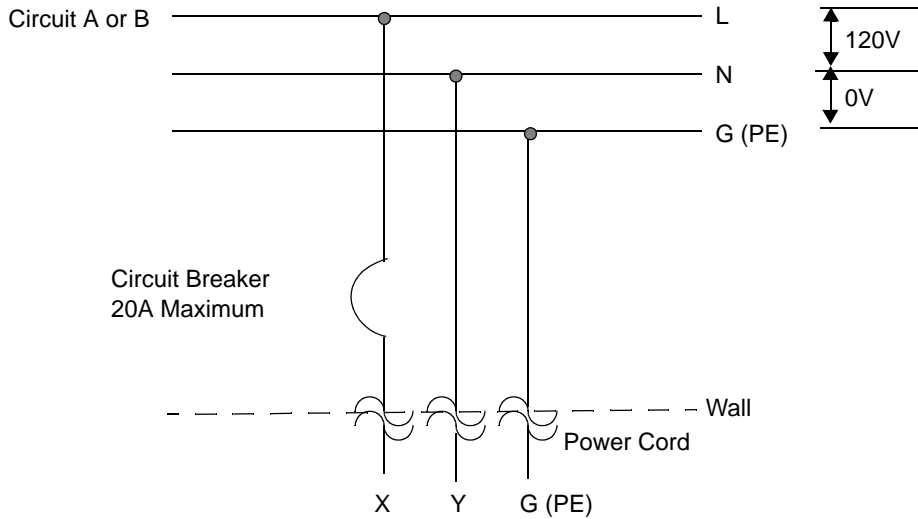

Figure B-5 shows a single-phase 240V AC circuit connection. Note that this application requires a single-pole circuit breaker.

Figure B-5. Single-Phase 240V AC Circuit Connection

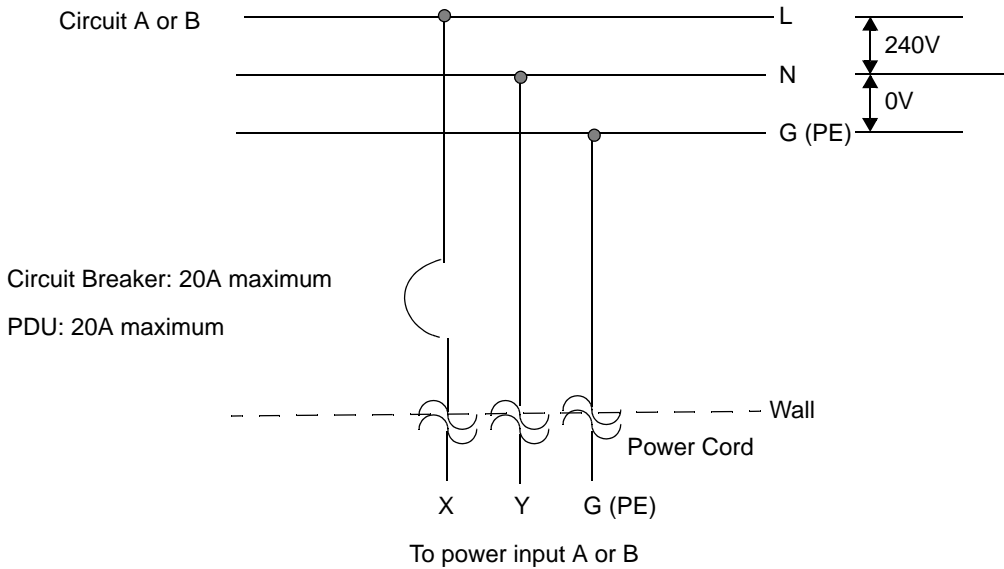

Figure B-6 shows a split-phase 120/240V AC circuit connection. Note that this application requires a double-pole circuit breaker.

Figure B-6. Split-Phase 120/240 Volts AC Circuit Connection

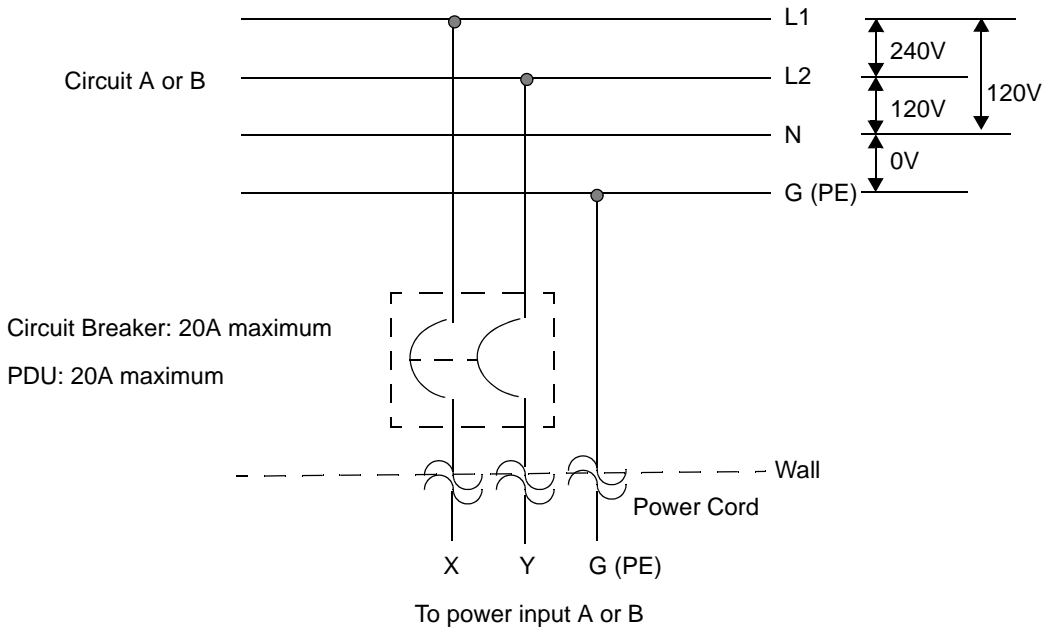

Figure B-7 shows a three-phase 208V AC, Y-, or Δ -source circuit connection, which is a phase-to-phase source connection. Note that the X and Y inputs on the system can be connected from L1 and L2, L2 and L3, or L1 and L3. This application requires a double-pole circuit breaker.

Figure B-7. Three-Phase 208V AC, Y-, or Δ -Source Circuit Connection, Phase-to-Phase

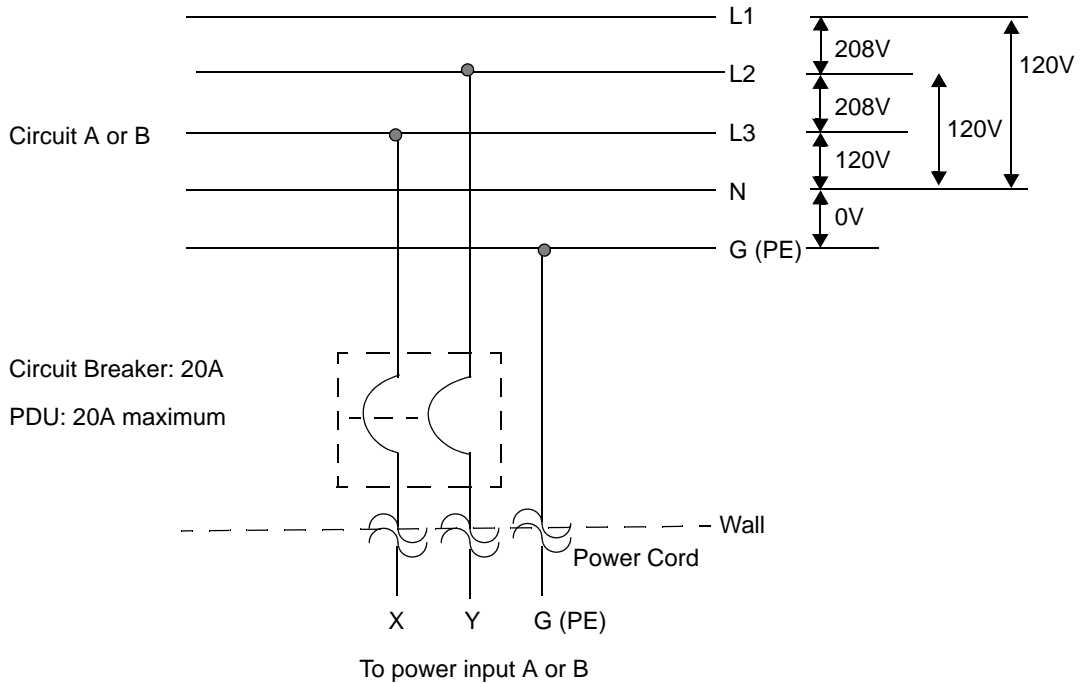
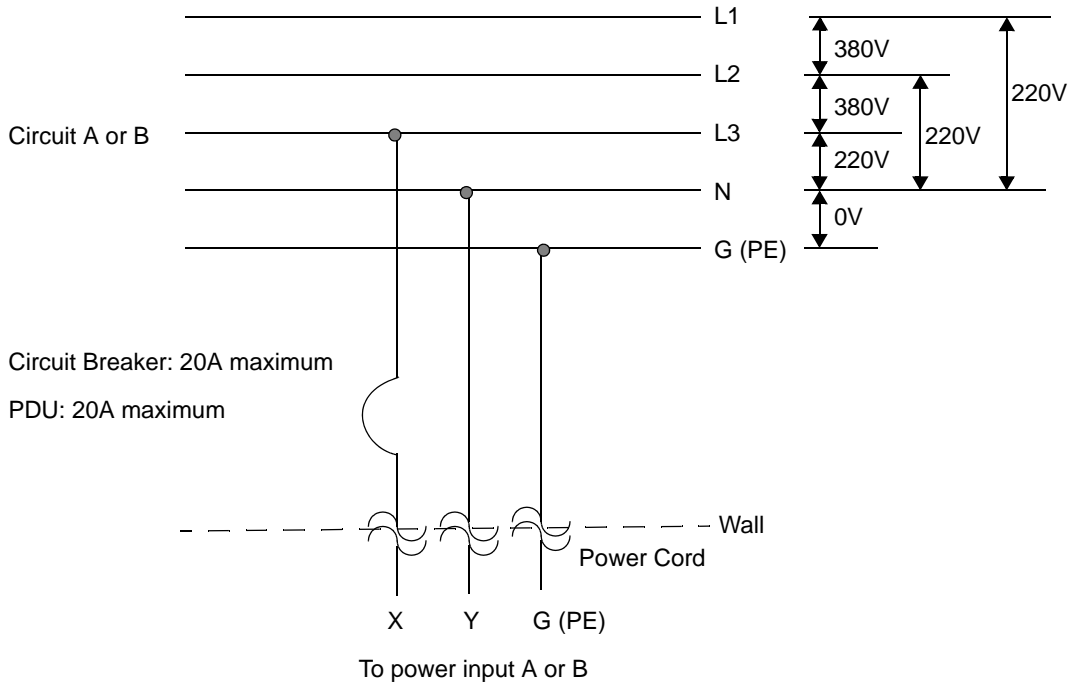

Figure B-8 shows a three-phase 380V AC, Y-, or Δ -source circuit connection, which is a phase-to-neutral source connection. Note that the system's X input can be connected to L1, L2, or L3. This application requires a single-pole circuit breaker.

Figure B-8. Three-Phase 380V AC, Y-, or Δ -Source Circuit Connection, Phase-to-Neutral



Electrical Power Connectors

Table B-1 describes the connectors required by the AC power cords that Stratus supplies with ftServer systems and optional devices.

Table B-1. Connectors for AC Power Outlets

Connector	Configuration	Rating	Description
NEMA L6-20		20A, 250 volts AC	2-pole, 3-wire
NEMA 5-15		15A, 125 volts AC	2-pole, 3-wire
CEE (7) VII		20A, 250 volts AC	2-pole, 3-wire
IEC 60309 (formerly IEC 309)		16-20A, 250 volts AC	2-pole, 3-wire
SABS 164-1:1992		16A, 250 volts AC	2-pole, 3-wire

Table B-1. Connectors for AC Power Outlets (Continued)

Connector	Configuration	Rating	Description
BS 1363/A		13A, 250 volts AC	2-pole, 3-wire
SEV 1011-S24507		10A, 250 volts AC	2-pole, 3-wire
SAA/3/15 AS/NZS 3112-1993		15A, 250 volts AC	2-pole, 3-wire
GB1002-1996		10A, 250 volts AC	2 pole, 3-wire

Appendix C

Standards Compliance

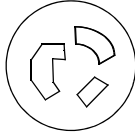
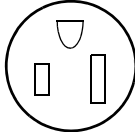
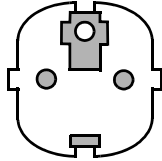
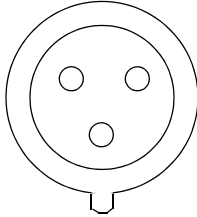
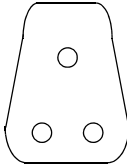
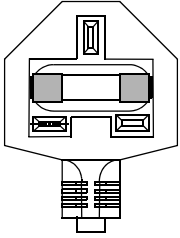
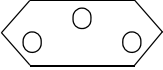
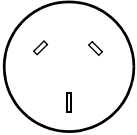
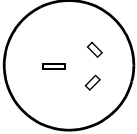
For compliance information, see the following:

- [“Electronic Interference, Immunity, Safety, and Noise Level Standards Compliance” on page C-1](#)
- [“Toxic and Hazardous Substances and Elements Disclosure” on page C-4](#)

Electronic Interference, Immunity, Safety, and Noise Level Standards Compliance

All ftServer systems comply with the electromagnetic interference (EMI), immunity, safety, and noise regulations listed in [Table C-1](#). All necessary agency labels are on the system.

NOTES _____

1. This system must be configured with the components listed and described in the product configuration specifications. Deviations from this list of components will void agency certification.
2. You must install all wiring, including power and communications cables, in compliance with local and national electrical code (in the United States, national electrical code NFPA 70). In addition, you must use shielded communications cables to remain in compliance with Federal Communications Commission (FCC) and other international Electromagnetic compatibility (EMC) regulations.
3. All EMC emissions compliance tests are performed at a third-party certified test laboratory.

This equipment has been tested and found to comply with the limits for a Class A digital device, pursuant to part 15 of the FCC Rules. These limits are designed to provide reasonable protection against harmful interference when the equipment is operated in a commercial environment. This equipment generates, uses, and can radiate radio frequency energy and, if not installed and used in accordance with the instruction

manual, may cause harmful interference to radio communications. Operation of this equipment in a residential area is likely to cause harmful interference, in which case the user will be required to correct the interference at his own expense.



WARNING

Changes or modification to the product could void the user's authority to operate the equipment.

Table C-1. Compliance Standards for ftServer 2600, 4500, 6300, and 6310 Systems (Class A)

Standard	Title	Country
EN 55022, Class A	Limits and methods of measurement of radio interference characteristics of Information Technology Equipment	European Union
EN 55024, Class A	Information Technology Equipment - Immunity characteristics - Limits and methods of measurement	European Union
EN 61000-3-2, Class A	Electromagnetic compatibility (EMC) – Part 3-2: Limits – Limits for harmonic current emissions (equipment input current \leq 16 A per phase)	European Union
EN 61000-3-3, Class A	Electromagnetic compatibility (EMC) – Part 3-3: Limits – Limits of voltage changes, voltage fluctuations and flicker in public low-voltage supply systems (equipment input current \leq 16 A per phase)	European Union
EN 60950-1	Safety of Information Technology Equipment	European Union
CB SCHEME IEC 60950-1	Safety of Information Technology Equipment	International
UL 60950-1, CSA C22.2 No. 60950-1-03	Safety of Information Technology Equipment	Certified to US and Canada standards
CISP22, Class A	Information Technology Equipment: Radio disturbance characteristics	International
FCC CFR47, Part 15, Class A	Code of Federal Regulations, Radio Frequency Devices	North America
AS/NZS CISPR 22, Class A	Information Technology Equipment - Radio Disturbance Characteristics - Limits and Methods of Measurement	Australia and New Zealand
ICES-003, Class A	Electronic Emissions from Data Processing Equipment and Electronic Office Machines	Canada

Table C-1. Compliance Standards for ftServer 2600, 4500, 6300, and 6310 Systems (Class A) (Con-

Standard	Title	Country
NOM-0190SCFI-1998	Data processing equipment safety	Mexico
GOST R	Safety of Information Technology Equipment, Electronic Emissions and Immunity	Russia
CISPR 22, Class A	Certificate of Compliance with the Radio Regulations	South Africa
KCC, Class A	Technical Requirements for EMI Safety for ITE	South Korea
CCC, Class A	CCC Qualification (EMC/Safety)	China
VCCI V-3, Class A	Voluntary Control Council for Interference by Information Technology Equipment	Japan
BSMI, Class A	Information technology equipment - Radio disturbance characteristics	Taiwan

VCCI Note

この装置は、クラス A 情報技術装置です。この装置を家庭環境で使用すると電波妨害を引き起こすことがあります。この場合には使用者が適切な対策を講ずるよう要求されることがあります。

V C C I - A

BSMI Note

警告使用者

這是甲類的資訊產品、在居住的環境中使用時、可能會造成射頻干擾、在這種情況下、使用者會被要求採取某些適當適對策

Energy Star Note

As defined by the EPA ENERGYSTAR Program Requirements for Computer Servers, Tier 1 requirements, this server is defined as a “Fully Fault Tolerant Server.” Presently there are no defined requirements, and this category of servers is ineligible to receive an Energy Star rating. As such there are no sales restrictions for local or federal agencies.

Toxic and Hazardous Substances and Elements Disclosure

ftServer 2600, 4500, 6300, and 6310 systems are compliant with the European Union’s Restriction of Hazardous Substances Directive (RoHS) based upon the exception for lead used in servers.



WARNING _____

**The lithium battery contains perchlorate material.
Special handling may apply. See
www.dtsc.ca.gov/hazardouswaste/perchlorate.**

Index

A

- AC power service requirements, 2-2
- APC UPS, 2-12
 - PowerChute Network Shutdown, 2-10
 - qualified models, 2-9
 - qualified Symmetra models, 2-9
- AS/NZS 3112-1993 connector, B-10
- A-side power source, 2-1
- ASN, site planning, 3-3, 4-10

B

- BS connector
 - 1363/A, B-10
- B-side power source, 2-1

C

- cabinets
 - configuration planning, 5-1, 5-5
 - requirements, 6-1
 - specifications, A-4
- cables
 - Ethernet, 4-7
 - Ethernet network, 4-7
 - Fibre Channel, 4-2, 4-3
 - planning for, 3-3, 4-1
 - telephone, 3-3
- CAC, getting assistance, 1-2
- CEE connector
 - (7) VII, B-9
- checklist for site planning, 1-2
- circuit, electrical
 - planning information, B-1
 - wiring diagrams, B-2
- communications cables
 - planning for, 4-1
- compliance, standards, C-1
- connectors, electrical, B-9
 - BS 1363/A, B-10
 - CEE (7) VII, B-9

- GB1002-1996, B-10
- IEC 60309, B-9
- NEMA 5-15, B-9
- NEMA L6-20, B-9
- SAA/3/15 AS/NZS 3112-1993, B-10
- SABS 164-1:1992, B-9
- SEV 1011-S24507, B-10

CPP

- UPS, 2-12
- current requirements, from PDU, 5-2
- Customer Assistance Center. *See* CAC

D

- dust contamination, 3-2

E

- earth reference ground, B-1
- electrical
 - connectors, B-9
 - grounding, B-1
 - power planning, 2-1
 - wiring, B-1
- EMC storage systems, 1-4, 4-2
- environmental requirements
 - maximum rate of temperature change, A-5
 - operating humidity, A-5
 - storage humidity, A-5
- Ethernet
 - network cables, 4-7
- Ethernet cables, 4-7

F

- Fibre Channel
 - cables, 4-3
 - connections, 4-2
 - switches electrical requirements, 2-3
- Fibre Channel switches, 1-5
- ftGateway, site planning information, 4-11

- ftScalable Storage systems, 1-4
 - Ethernet cables, 4-9
 - Ethernet connections, 4-7
 - Fibre Channel connections, 4-2
 - management PC, 4-7
- ftServer Access Adapters, 4-12

G

- GB connector
 - GB1002-1996, B-10
- grounding the system, 2-15, 6-2, B-1

H

- hubs, network, 3-3

I

- IEC connector
 - 60309, B-9
- iSCSI storage, 4-9

J

- jacks, Ethernet, 3-3

L

- LCD monitor units
 - power cords, 2-13

M

- management PC
 - for ftScalable Storage systems, 4-7, 4-9
- monitors
 - power cords, 2-13
 - requirements, 6-5

N

- NEMA connector
 - 5-15, B-9
 - L6-20, B-9
- network (Ethernet) cables, 4-7
- network management card, UPS, 2-10

O

- optical Fibre Channel connections, 4-2

P

- PCIe adapters
 - U104, 4-8
 - U105, 4-8
 - U106, 4-2
 - U107, 4-2
 - U108, 4-8
 - U539F, 4-2
 - U777F, 4-2
- PDU's
 - configuration planning, 5-1
 - power (jumper) cables, 2-15
 - power cords, 2-14
 - site planning, A-8
 - specifications, A-9
 - usage calculation
 - sample, 5-4
 - worksheets, 5-4
- power (AC)
 - cords
 - LCD monitor units, 2-13
 - monitors, 2-13
 - storage enclosures, 2-13
 - systems, 2-13
 - tape-drive enclosures, 2-13
 - electrical requirements, 2-2
 - PDU connections, illustrated, 2-11
 - service requirements, 2-2, 2-4, 2-5
 - A-side, 2-4, 2-5
 - B-side, 2-4, 2-5
 - sources, 2-1
 - direct, 2-6
 - UPS, 2-10, 2-12
 - system connections, illustrated, 2-6
 - UPS connections, illustrated, 2-12
 - wall outlets, 2-4, 3-3
- PowerChute Network Shutdown, 2-10
- protective earth ground, B-1

R

- racks
 - configuration planning, 5-1, 5-5
 - requirements, 6-1
- removing power, 1-10
- room requirements, 3-1

S

- SAA/3/15 AS/NZS connector
 - 3112-1993, B-10
- SABS connector
 - 164-1:1992, B-9
- safety notices, 1-10
- service requirements, AC-power, 2-2
- SEV connector
 - 1011-S24507, B-10
- single-phase circuit connections
 - 120 V AC, B-4
 - 240 V AC, B-5
- site planning
 - checklist, 1-2
 - overview, 1-1
- space planning, 3-1
 - cables, 3-3
 - future expansion, 3-2
 - room requirements, 3-1
- specifications
 - AC power, 2-2
 - cabinet, A-4
 - CPU-I/O enclosure, A-5
 - PDUs, A-9
 - rack-mountable system, A-1
- split-phase circuit connections
 - 120–240 V AC, B-6
- standards compliance, C-1
- star ground, B-2
- Stratus Customer Assistance Center. *See* CAC
- switches
 - circuit breaker
 - PDU, A-8
 - Ethernet
 - cable planning, 3-3, 4-8
 - Fibre Channel, 1-5
 - site network, 3-3
- system power cords, 2-13
- system specifications
 - rack-mounted systems, A-1

T

- tape-drive enclosures
 - power cords, 2-13
- technical support. *See* CAC
- telephone lines, 4-10
 - for ASN modem assembly, 1-3, 4-10
 - for support calls, 4-10

telephones

- for support calls, 1-3
- three-phase circuit connections
 - 208 V AC, B-7
 - 380 V AC, B-8

U

- U104 PCIe Ethernet adapters, 4-8
- U105 PCIe Ethernet adapters, 4-8
- U106 PCIe SAS adapters, 4-2
- U107 PCIe Optical Fibre Channel adapters, 4-2
- U108 PCIe Ethernet adapters, 4-8
- U539F PCIe Optical Fibre Channel adapters, 4-2
- U777F PCIe Optical Fibre Channel adapters, 4-2
- uninterruptible power supply (UPS). *See* UPS
- UPS, 2-12
 - network communication hardware, 2-10
 - network communication software, 2-10
 - network management card, 2-10
 - PDU connections, 2-10
 - rack system connections, 2-12

V

- VTMs
 - cables, 4-8
 - in an ftGateway group, 4-11

W

- wiring, electrical, B-1

