

# **Stratus<sup>®</sup> ftServer<sup>®</sup> 2510, 4410, and 6210 Systems: Site Planning Guide**

Stratus Technologies  
R627-03

---

# Notice

The information contained in this document is subject to change without notice.

UNLESS EXPRESSLY SET FORTH IN A WRITTEN AGREEMENT SIGNED BY AN AUTHORIZED REPRESENTATIVE OF STRATUS TECHNOLOGIES, STRATUS MAKES NO WARRANTY OR REPRESENTATION OF ANY KIND WITH RESPECT TO THE INFORMATION CONTAINED HEREIN, INCLUDING WARRANTY OF MERCHANTABILITY AND FITNESS FOR A PURPOSE. Stratus Technologies assumes no responsibility or obligation of any kind for any errors contained herein or in connection with the furnishing, performance, or use of this document.

Software described in Stratus documents (a) is the property of Stratus Technologies Bermuda, Ltd. or the third party, (b) is furnished only under license, and (c) may be copied or used only as expressly permitted under the terms of the license.

Stratus documentation describes all supported features of the user interfaces and the application programming interfaces (API) developed by Stratus. Any undocumented features of these interfaces are intended solely for use by Stratus personnel and are subject to change without warning.

This document is protected by copyright. All rights are reserved. No part of this document may be copied, reproduced, or translated, either mechanically or electronically, without the prior written consent of Stratus Technologies.

Stratus, the Stratus logo, ftServer, and the ftServer logo are registered trademarks of Stratus Technologies Bermuda, Ltd.

The Stratus Technologies logo, the Stratus 24 x 7 logo, ActiveService, ftScalable, and Active Upgrade are trademarks of Stratus Technologies Bermuda, Ltd.

The registered trademark Linux is used pursuant to a sublicense from the Linux Mark Institute, the exclusive licensee of Linus Torvalds, owner of the mark on a world-wide basis. FLEXIm is a registered trademark of Macrovision Corporation.

All other trademarks are the property of their respective owners

Manual Name: *Stratus ftServer 2510, 4410, and 6210 Systems: Site Planning Guide*

Part Number: R627

Revision Number: 03

ftServer System Software for the Linux Operating System, Release Number: 6.0.2

ftServer System Software for VMware Infrastructure, Release Number: 1.1.0

ftServer System Software for the Windows Operating System, Release Number: 5.3.0

Publication Date: January 2009

Stratus Technologies, Inc.

111 Powdermill Road

Maynard, Massachusetts 01754-3409

© 2009 Stratus Technologies Bermuda, Ltd. All rights reserved.

---

# Contents

---

---

<b>Preface</b>	ix
----------------	----

---

<b>1. Site Planning for ftServer 2510, 4410, and 6210 Systems</b>	1-1
Site Planning Overview	1-1
Site Planning for Fault-Tolerant Systems	1-3
Site Planning Checklist	1-4
System Documentation	1-8
Safety Notices	1-11

---

<b>2. Electrical Power Planning</b>	2-1
Redundant Power Sources	2-1
AC Power and HVAC Service Requirements	2-2
AC Power Outlet Requirements	2-4
Connecting a System Directly to Separate AC Sources	2-6
Selecting a UPS Unit for ftServer Systems	2-9
Communicating with a UPS over a Network	2-11
Connecting Power to Systems, PDUs, and a UPS	2-11
Connecting a System Directly to a UPS	2-13
Power Cord Summary	2-15
Power Cords for ftServer Systems and Peripheral	
Components	2-15
PDU Power Cords	2-16
Grounding Requirements	2-17

---

<b>3. Space Planning</b>	3-1
Room Requirements	3-1
Planning for Cables	3-3

---

<b>4. Communications Line Planning</b>	4-1
SCSI Connections	4-2

---

Fibre Channel Connections	4-3
Ethernet Cables	4-5
Serial (Null Modem) Cable Connections	4-8
Telephone Line Connections	4-8
Site Planning for Systems in an ftGateway Group	4-9

---

<b>5. Rack Configuration Planning</b>	5-1
Using PDUs	5-1
Determining PDU Requirements	5-2
Sample PDU Usage Calculation	5-4

---

<b>6. Cabinet and Monitor Requirements</b>	6-1
Cabinet Requirements	6-1
Monitor Requirements	6-4
Management PC Requirements	6-4

---

<b>Appendix A. System Specifications</b>	A-1
Pedestal System Specifications	A-1
Rack-Mountable System Specifications	A-7
AAP86900 and AAP87600 PDU Specifications	A-12

---

<b>Appendix B. Electrical Circuit and Wiring Information</b>	B-1
Fault Protection Requirements	B-1
Grounding Considerations	B-1
Circuit Wiring Diagrams	B-2
Electrical Power Connectors	B-8

---

<b>Appendix C. Standards Compliance</b>	C-1
Electronic Interference, Immunity, Safety, and Noise Level	
Standards Compliance	C-1
Toxic and Hazardous Substances and Elements Disclosure	C-4

---

<b>Index</b>	Index-1
--------------	---------

---

# Figures

Figure 2-1.	Rack-Mounted System Connected Directly to AC Power	2-6
Figure 2-2.	Pedestal System Connected Directly to AC Power	2-7
Figure 2-3.	PDUs Connected Directly to AC Power	2-8
Figure 2-4.	Power Cord Connections for Systems, PDUs, and a UPS	2-12
Figure 2-5.	Rack-Mountable Systems: A-Side Power Connected Directly to a UPS	2-13
Figure 2-6.	Pedestal Systems: A-Side Power Connected Directly to a UPS	2-14
Figure 4-1.	SCSI Connections to Tape Drives	4-2
Figure 4-2.	Fibre Channel Connections to an ftScalable Storage System Using Switches	4-4
Figure 4-3.	Direct-Attach Fibre Channel Connections to an ftScalable Storage System	4-5
Figure 6-1.	Rail Clearance	6-3
Figure A-1.	Pedestal ftServer 2510 or 4410 System: Front View	A-2
Figure A-2.	Pedestal ftServer 2510 or 4410 System (No VTMs): Rear View	A-3
Figure A-3.	Pedestal ftServer 2510 or 4410 System (With VTMs): Rear View	A-4
Figure A-4.	Rack-Mountable ftServer 2510, 4410, or 6210 System: Front View	A-7
Figure A-5.	Rack-Mountable ftServer 2510, 4410, or 6210 System (With VTMs): Rear View	A-8
Figure A-6.	AAP86900 PDU	A-12
Figure A-7.	AAP87600 PDU	A-13
Figure B-1.	Star Ground Example	B-2
Figure B-2.	Power Input Labeling	B-3
Figure B-3.	Single-Phase 120V AC Circuit Connection	B-3
Figure B-4.	Single-Phase 240V AC Circuit Connection	B-4
Figure B-5.	Split-Phase 120/240 Volts AC Circuit Connection	B-5
Figure B-6.	Three-Phase 208V AC, Y-, or D-Source Circuit Connection, Phase-to-Phase	B-6
Figure B-7.	Three-Phase 380V AC, Y-, or D-Source Circuit Connection, Phase-to-Neutral	B-7

---

## Tables

Table 1-1.	Ethernet PCI Adapters	1-4
Table 1-2.	ftServer 2510, 4410, and 6210 System Documentation	1-8
Table 1-3.	Additional System Documentation for Windows Systems	1-9
Table 1-4.	Additional System Documentation for Linux Systems	1-10
Table 1-5.	Additional System Documentation for ESX Server Systems	1-10
Table 2-1.	Worksheet: Determining A-Side Power Requirements	2-3
Table 2-2.	Worksheet: Determining B-Side Power Requirements	2-3
Table 2-3.	Worksheet: Determining External Power Requirements	2-3
Table 2-4.	HVAC Requirements	2-4
Table 2-5.	Worksheet: A-Side External Power Outlet Requirements: PDUs Used	2-4
Table 2-6.	Worksheet: B-Side External Power Outlet Requirements: PDUs Used	2-4
Table 2-7.	Worksheet: A-Side External Power Outlet Requirements: No PDUs	2-5
Table 2-8.	Worksheet: B-Side External Power Outlet Requirements: No PDUs	2-5
Table 2-9.	APC Symmetra Models for PDUs or for Multiple Systems	2-10
Table 2-10.	APC UPS Models for a Single Rack-Mountable System	2-10
Table 2-11.	APC UPS Models for a Single Pedestal System	2-10
Table 2-12.	Power Cords from ftServer Systems and Peripheral Components to AC Power	2-15
Table 2-13.	Power Cords Between ftServer Systems or Storage Systems and a UPS	2-16
Table 2-14.	Power Cords to Connect PDUs Directly to AC Power Mains	2-16
Table 2-15.	AC Power Cords to Connect PDUs to a UPS	2-17
Table 2-16.	System Power ( <i>Jumper</i> ) Cables to Connect ftServer Systems to PDUs	2-17
Table 4-1.	Single-Initiated SCSI Tape Cables	4-2
Table 4-2.	Optical Fibre Channel Cables	4-3
Table 4-3.	Customer-Supplied Ethernet Cables	4-6
Table 4-4.	Null Modem Cables	4-8
Table 5-1.	Current and Rack-Space Requirements	5-2
Table 5-2.	Calculating A-Side PDU and Rack-Space Requirements	5-3
Table 5-3.	Sample: Current and Rack-Space Requirements	5-4

---

Table 5-4.	Sample: Calculating A-Side PDU and Rack-Space Requirements	5-4
Table A-1.	Pedestal ftServer 2510 or 4410 System Specifications	A-5
Table A-2.	Cabinet Dimensions	A-8
Table A-3.	Rack-Mountable ftServer 2510, 4410, and 6210 System Specifications	A-9
Table A-4.	AAP87600 and AAP86900 PDU: Specifications	A-14
Table B-1.	Connectors for AC Power Outlets	B-8
Table C-1.	Compliance Standards for ftServer 2510, 4410, and 6210 Systems	C-2



---

# Preface

The *Stratus ftServer 2510, 4410, and 6210 Systems: Site Planning Guide (R627)* documents the site requirements and customer responsibilities related to preparing a site for the installation of ftServer 2510, 4410, and 6210 systems.

This document is intended for those responsible for preparing a site for the installation of an ftServer 2510, 4410, or 6210 system.

## Revision Information

This document is a revision with minor changes.

## Notation Conventions

This document uses the notation conventions described in this section.

## Warnings, Cautions, and Notes

Warnings, cautions, and notes provide special information and have the following meanings:



### **WARNING** \_\_\_\_\_

A warning indicates a situation where failure to take or avoid a specified action could cause bodily harm or loss of life.



### **CAUTION** \_\_\_\_\_

A caution indicates a situation where failure to take or avoid a specified action could damage a hardware device, program, system, or data.

### **NOTE** \_\_\_\_\_

A note provides important information about the operation of an ftServer system.

## Typographical Conventions

The following typographical conventions are used in this document:

- The bold font emphasizes words in text. For example:  
**Before** handling or replacing system components, make sure that you are properly grounded by using a grounded wrist strap.
- The italic font introduces new terms. For example:  
Many hardware components are *customer-replaceable units* (CRUs), which can be replaced on-site by system administrators with minimal training or tools.

## Getting Help

If you have a technical question about ftServer system hardware or software, try these online resources first:

- **Online documentation at the StrataDOC Web site.** Stratus provides complimentary access to StrataDOC, an online-documentation service that enables you to view, search, download, and print customer documentation. You can access StrataDOC at the following Web site: <http://stratadoc.stratus.com>  
A copy of the StrataDOC CD-ROM for your system is included with this release. To order additional copies of the StrataDOC CD-ROM or to obtain copies of printed manuals, do one of the following:
  - If you are in North America, call the Stratus Customer Assistance Center (CAC) at (800) 221-6588 or (800) 828-8513, 24 hours a day, 7 days a week.
  - If you are located outside North America, contact your nearest Stratus sales office, CAC office, or distributor; for CAC phone numbers outside the U.S., see <http://www.stratus.com/support/cac/index.htm>.

Request one of the following products:

- *ftServer StrataDOC (Windows Version)* CD (part number R003FCDK)
- *ftServer StrataDOC (Linux Version)* CD (part number R003LCDK)
- *ftServer StrataDOC (VMware Version)* CD (part number R003ECDK)
- **Online support from Stratus Customer Service.** You can find the latest technical information about an ftServer system through online product support at the Stratus Technical Support Web site, <http://www.stratus.com/support/technics.htm>
- **Online product support for Microsoft® products.** Your primary source for support is the computer manufacturer who provided your software, or an authorized Microsoft Support Provider. You can also find the latest technical information about Microsoft Windows® and other Microsoft products through online

product support at the Microsoft Help and Support Web site:  
<http://support.microsoft.com/>

- **Online product support for Red Hat® Linux® products.** Your primary source for support is the manufacturer who provided your software, or Red Hat Global Support Services. You can also find the latest technical information about Red Hat Enterprise and Standard Linux through online product support at the Red Hat Support Web site:

<http://www.redhat.com/apps/support/>

- **Online product support for VMware® Infrastructure products.** You can find the latest technical information about VMware Infrastructure through online product support at the VMware Support Web site: <http://www.vmware.com/support/>

If you are unable to resolve your questions with the help available at these online sites, and the ftServer system is covered by a service agreement, please contact the Stratus Customer Assistance Center (CAC) or your authorized Stratus service representative. For information about how to contact the CAC, see the following Web site:

<http://www.stratus.com/support/cac/>

## Commenting on the Documentation

To provide corrections and suggestions on the documentation, send your comments in one of the following ways:

- By clicking the **site feedback** link at the bottom of a Help topic. Information to identify the topic is supplied in the StrataDOC Web Site Feedback form.
- By email to [Comments@stratus.com](mailto:Comments@stratus.com). If it is possible, please include specific information about the documentation on which you are commenting:
  - For a printed document or a document in PDF format, include the title and part number from the Notice page and the page numbers.
  - For online documentation, include the Help subject and topic title.

This information will assist Stratus Information Development in making any needed changes to the ftServer system documentation. Your assistance is most appreciated.

## Regulatory Notice

[Appendix C, “Standards Compliance”](#) provides all regulatory notices.



---

# Chapter 1

## Site Planning for ftServer 2510, 4410, and 6210 Systems

For an overview of required information and tasks you need to perform to prepare a site for ftServer 2510, 4410, and 6210 systems, see:

- [“Site Planning Overview” on page 1-1](#)
- [“Site Planning for Fault-Tolerant Systems” on page 1-3](#)
- [“Site Planning Checklist” on page 1-4](#)
- [“System Documentation” on page 1-8](#)
- [“Safety Notices” on page 1-11](#)

### Site Planning Overview

[Site planning for fault-tolerant systems](#) includes:

- [Purchasing an appropriate cabinet and monitor](#)

If you do not purchase a monitor from Stratus, provide a monitor that meets the system’s requirements.

#### NOTES \_\_\_\_\_

1. A monitor, keyboard, and mouse are required to install ftServer System Software (ftSSS).
2. You cannot use the monitor, keyboard, and mouse after you install ESX Server and ftSSS, Therefore, plan to provide a management PC to which you can connect the system over a serial connection.

If you do not purchase a cabinet from Stratus, provide a cabinet that meets the system’s requirements.

- [Electrical power planning](#)

Provide electrical power sources that meet the requirements of the system and optional components, optionally including the purchase of a qualified [uninterruptible power supply \(UPS\)](#).

- [Space planning](#)

Provide adequate space for the system or cabinet and for a desk or table to accommodate components outside a cabinet. Also provide enough space for servicing the systems and components.

Provide an environment that meets the system's requirements for ambient temperature and air quality.

- [Communications line planning](#)

Provide sufficient network and analog telephone lines and plan the location of the system and external components to accommodate the lengths of the connecting cables.

For ESX Server systems, provide a computer to act as a management PC. Also provide a serial cable to connect the management PC to the ftServer system, or provide some other way to connect to the ftServer system through a serial connection. After you install the operating system and ftSSS, you cannot use a monitor, mouse, and keyboard directly attached to the system.

- [Rack space planning](#)

Ensure that the power distribution units (PDUs) supply sufficient power to the components you have purchased and that you have sufficient space available in an appropriate cabinet.

Use the [“Site Planning Checklist” on page 1-4](#) to track your site preparation progress.

For information about obtaining documents related to your ftServer system, see [“System Documentation” on page 1-8](#).

During the site planning and preparation processes, work closely with your facilities group or contractor to determine space, power, and environmental requirements. Enlist their help to provide a suitable location with sufficient alternating current (AC) power, heating, ventilation and air conditioning (HVAC) capabilities, and network and telephone connections.

If your system is covered by a service agreement and you need help with site planning, contact the Stratus Customer Assistance Center (CAC) or your authorized Stratus service representative. If you have a contract with the CAC or your authorized Stratus service representative to install the system, contact them after you have prepared the

installation site and moved the system to the site. For more information about the CAC, see [Getting Help](#) in the Preface or the <http://www.stratus.com/support/cac/> Web site.

See [Appendix A, “System Specifications”](#) for the specifications of the base ftServer systems and of PDUs. See the *Stratus ftServer Systems: Peripherals Site Planning Guide (R582)* for specifications of other components.

## Site Planning for Fault-Tolerant Systems

Consider the following specific fault-tolerant features of ftServer systems for site planning:

- Lockstep technology means that the systems contain redundant hardware. The systems contain two enclosures, each containing a full computing environment that consists of a CPU element and an I/O element.

If a component in a CPU element malfunctions, the corresponding CPU element in the other enclosure, which is processing the same information in lockstep, continues processing without interruption. If a component in the I/O element malfunctions, the system fails operation over to the corresponding element in the other enclosure and continues to operate normally. The only consequences are that the system is less fault tolerant, and any I/O throughput distributed between the enclosures may be reduced. To restore full fault tolerance, an enclosure can be replaced without taking the system offline.

- ftServer systems can connect to the ActiveService Network (ASN).

Connecting a system to the ASN allows the CAC or your authorized Stratus service representative to remotely diagnose, troubleshoot, and resolve problems online.

To enable connectivity to the ASN, an ASN modem can be attached directly to the system. In Windows and Linux systems, two partnered Virtual Technician Modules (VTMs), if installed in the system, manage the modem. The VTMs can also connect to the ASN through their Ethernet ports, if the network to which they are attached has Internet access. Systems without modems or VTMs can connect to the ASN through an Internet connection.

### NOTE \_\_\_\_\_

ftSSS for VMware Infrastructure does not support VTMs.

Systems that connect to the ASN using partnered VTMs provide the highest level of availability. VTMs provide ASN connectivity even when the operating system is not operational. VTMs also allow internal administrators to remotely service the system over a telephone line or IP network, regardless of the state of the operating system.

If VTMs are not present, system software manages the modems and ASN connectivity is only possible if the operating system is operational.

## Site Planning Checklist

Referring to the information in this document, answer the following questions:

### Planning for ASN Connectivity

- Will your system connect to the ASN? If so, will it connect over an ASN modem or the Internet?
- If your system will use the Internet to connect to the ASN, do you have an Internet connection available?
- If your system will use an ASN modem, do you have an external analog telephone line available for the ASN modem?

#### NOTE

A dedicated phone line provides the most reliable service. ASN calls routed through a PBX may be slow due to load on the PBX, or may not complete successfully due to disconnections. If you must use a PBX, do not route the telephone extension through a switchboard; instead, provide a direct-dial analog number.

- Do you have an additional telephone connection and telephone near the operator's station for voice communications when calling for support?

### Planning for Network Connectivity

- The system contains four embedded 10/100/1000 megabits-per-second (Mbps) Ethernet ports. Will your system additionally include any of the following PCI adapters for network communications? If so, in [Table 1-1](#), indicate the total number of ports, and plan network connections for all Ethernet ports you will use.

**Table 1-1. Ethernet PCI Adapters**

Adapter	Total Number of Ports
U574F-LC Dual-Port Fiber Gigabit Ethernet Adapter	
U575F Dual-Port Copper Gigabit Ethernet Adapter	

#### NOTES

1. The four embedded physical adapters provide the basic requirements for VMware ESX Server: two

logical controllers, one for the service console and the other for the virtual machines.

2. Because a VMware ESX Server system contains at least one pair of host bus adapters (HBAs), it supports a maximum of two more pairs of Ethernet adapters.

### Planning for Optional Components

- Will your system connect to external storage enclosures? If so, the system requires a pair of HBAs, which are provided when you order the storage enclosure. If you order the enclosure at the same time you order the system, the required HBAs are installed at the factory. See the *Stratus ftServer Systems: Peripherals Site Planning Guide (R582)* for descriptions of the storage enclosures provided by Stratus and the names of the PCI adapters required for supported storage enclosures.

#### NOTES \_\_\_\_\_

1. An ftServer system that runs ESX Server boots from a logical unit number (LUN) on an external storage system and so requires at least one pair of HBAs and at least one ftScalable™ Storage system or EMC® CLARiiON® or Symmetrix® storage system.
  2. An ftServer system that runs the Windows operating system supports ftScalable Storage systems and EMC CLARiiON and Symmetrix storage systems.
  3. An ftServer system that runs the Linux operating system supports ftScalable Storage systems, EMC CLARiiON and Symmetrix storage systems, and HP Storage Works Enterprise Virtual Arrays (EVAs).
- If your system will connect to external storage enclosures, will it be through a storage area network (SAN)? If so, do you have a minimum of two switches that can accommodate the cables from the pairs of HBAs in the ftServer system?

#### NOTES \_\_\_\_\_

1. Stratus has successfully tested the Brocade® 200E Fibre Channel (FC) switch. Other model switches may also be compatible as long as they can be configured in the same manner as the Brocade 200E switch.
2. You must connect ESX Server systems to SAN storage, and therefore, must provide a pair of Fibre Channel switches.

- Will you supply your own monitor or will Stratus supply the monitor, keyboard, and mouse? Is the monitor rack-mountable or do you need to provide a table or desk?
- Will your Windows or Linux system include any tape-drive enclosures? The tape-drive enclosure supplied with your system is rack-mountable. If you order the tape drive at the same time you order the system, the required PCI adapter is installed in the system. See the *Stratus ftServer Systems: Peripherals Site Planning Guide (R582)* for descriptions of the enclosures and the names of the required PCI adapters.

**NOTE** \_\_\_\_\_

ftSSS for VMware Infrastructure does not support tape drives.

### **Planning AC Power**

- Will you provide power to both sides of the system through a pair of PDUs?
- Will you protect the system power with a UPS?
- What optional components will you use?
- What are the AC power requirements of your system, including all optional components?
- What are the lengths and types of the power cords that are provided for the PDUs or system, and optional components?
- What type of AC receptacles do you need to provide?
- Is the AC power service wired properly?

### **Planning Space for Your System**

- Will your system and its external components fit where you plan to place them?
- If you are rack-mounting the system, what is the height of the cabinet you will use and what is the total height of the systems and components that will be installed in the cabinet? Will the items fit into the cabinet? What components will be located outside the cabinet?
- What are the lengths and types of the interface and communications cables that will connect to your system?
- Have you created a sketch of how you plan to arrange the system at the installation site? Consider the available cable lengths, the placement of external devices, and the location of network and voice communication connections.

On the sketch, show the following:

- Location of the system and its external components
- Power cords, and telephone and interface cables

- Locations of AC power receptacles, phone jacks, Ethernet jacks, switches, and hubs

NOTE \_\_\_\_\_

Make sure that all cords and cables are long enough to reach between their respective components and connectors. Route all cables out of the way of foot traffic.

### Working with Other Groups

- Have you provided your facilities group and contractors with the sketch of how you plan to arrange the system and copies of the following?
  - [“AC Power and HVAC Service Requirements” on page 2-2](#)
  - [“Redundant Power Sources” on page 2-1](#)
  - Tables [2-1](#), [2-2](#), and [2-3](#), worksheets for determining AC power requirements
  - Tables [2-5](#) and [2-6](#) (if you are using PDUs) or Tables [2-7](#) and [2-8](#) (if you are not using PDUs), worksheets for determining the number of external power outlets required
  - [Appendix B, “Electrical Circuit and Wiring Information”](#)
  - Any notes you have about site planning
- Have you reviewed and discussed the requirements with the facilities personnel and contractors to ensure that all site modifications are understood and implemented?

If you have any questions about the number and types of components, contact your Stratus account executive or distributor.

## System Documentation

Table 1-2 lists the hardware documents for ftServer 2510, 4410, and 6210 systems, and the tasks described in each document. Also see Table 1-3 (for Windows systems) for Windows systems), Table 1-4 (for Linux systems), or Table 1-5 (for ESX Server systems).

**Table 1-2. ftServer 2510, 4410, and 6210 System Documentation**

Document	Task
<i>Stratus ActiveService Network Configuration Guide</i> (R072)	Configure your system for support by the ASN
<i>Stratus ftServer Systems: PCI Adapter Guide</i> (R461)	Install, configure, replace, or troubleshoot PCI adapters
<i>Stratus ftServer Systems: Technical Reference Guide</i> (R550)	Consult technical reference information for ftServer systems  Change BIOS settings in the ftServer Setup program
<i>Stratus ftServer Systems: Peripherals Site Planning Guide</i> (R582)	Find information about optional equipment that you have ordered with your system that is needed to complete site preparation
<i>Stratus ftServer 2510, 4410, and 6210 Systems: Site Planning Guide</i> (R627)	Prepare a site for installation of your ftServer system
<i>Stratus ftServer 2510, 4410, and 6210 Systems: Operation and Maintenance Guide</i> (R626)	Start up, shut down, and operate your system  Troubleshoot system hardware  Remove and replace CRUs, including PCI adapters
<i>Stratus ftServer 2510, 4410, and 6210 Systems: Installation Guide</i> (R628)	Install your system, including mounting the system in a cabinet  Install ftSSS and the operating system on your new system  Configure VTMs, if present  Start the system for the first time
<i>Read Me First: Unpacking ftServer 2510, 4410, and 6210 Systems</i> (R629)	Inspect and unpack ftServer system hardware that you install in your cabinet

[Table 1-3](#) lists additional documents for ftServer 2510, 4410, and 6210 systems that run ftSSS for the Windows operating system, and the tasks described in each document.

**Table 1-3. Additional System Documentation for Windows Systems**

Document	Task
<i>Release Notes: Stratus ftServer System Software for the Windows Operating System (R004W)</i>	Learn the contents of the latest ftServer System Software release  Learn the latest information about the product  Learn about significant known problems and how to work around or avoid the problems
<i>Stratus ftServer System Software: Installation and Configuration for Windows Systems (R002W)</i>	Respond to Mini-Setup questions  Install or reinstall ftSSS and Windows Server software  Upgrade software and BIOS, BMC, and VTM firmware  Configure ftSSS  Set up your system to communicate with a UPS
<i>Stratus ftServer System Administrator's Guide for the Windows Operating System (R014W)</i>	Use tools that are provided by the operating system software, ftServer System Software, and other vendors to manage and troubleshoot the system  Manage data-storage devices
<i>Stratus Virtual Technician Module User's Guide (R561)</i>	Use the VTM console to remotely control, monitor, and troubleshoot your system

[Table 1-4](#) lists additional documents for ftServer 2510, 4410, and 6210 systems that run ftSSS for the Linux operating system, and the tasks described in each document.

**Table 1-4. Additional System Documentation for Linux Systems**

Document	Task
<i>Release Notes: Stratus ftServer System Software for the Linux Operating System (R005L)</i>	<p>Learn the contents of the latest ftServer System Software release</p> <p>Learn the latest information about the product</p> <p>Learn about significant known problems and how to work around or avoid the problems</p>
<i>Stratus ftServer System Software: Installation for Linux Systems (R013L)</i>	Install and update the Linux operating system, ftServer System Software, and BIOS and BMC firmware
<i>Stratus ftServer System Administrator's Guide for the Linux Operating System (R003L)</i>	<p>Use tools that are provided by the operating system software, ftServer System Software, and other vendors to manage and troubleshoot the system</p> <p>Manage network connections and data storage devices</p> <p>Install and configure the Simple Network Management Protocol</p>
<i>Stratus Virtual Technician Module User's Guide (R561)</i>	Use the VTM console to remotely control, monitor, and troubleshoot your system

[Table 1-5](#) lists additional documents for ftServer 4410 and 6210 systems that run ftSSS for VMware Infrastructure, and the tasks described in each document.

**Table 1-5. Additional System Documentation for ESX Server Systems**

Document	Task
<i>Stratus ftServer System Administrator's Guide for VMware Infrastructure (R002E)</i>	<p>Use tools that are provided by VMware Infrastructure, ftServer System Software, and other vendors to manage and troubleshoot the system</p> <p>Install and upgrade VMware ESX Server</p> <p>Install and upgrade ftSSS, and BIOS and BMC firmware</p> <p>Manage data storage devices</p>

Table 1-5. Additional System Documentation for ESX Server Systems (Continued)

Document	Task
<i>Release Notes: Stratus ftServer System Software for VMware Infrastructure (R005L)</i>	<p>Learn the contents of the latest ftServer System Software release</p> <p>Learn the latest information about the product</p> <p>Learn about significant known problems and how to work around or avoid the problems</p>
<i>VMware SAN System Design and Deployment Guide</i> <a href="http://www.vmware.com/pdf/vi3_san_design_deploy.pdf">http://www.vmware.com/pdf/vi3_san_design_deploy.pdf</a>	Learn how to design and deploy virtual infrastructure systems using VMware Infrastructure 3 with storage area networks (SANs).

## Safety Notices



### WARNING \_\_\_\_\_

Risk of explosion if battery is replaced by an incorrect type. Dispose of used batteries according to the instructions provided with the battery.



### WARNING \_\_\_\_\_

The system uses two power cords to provide redundant sources of power. To fully remove power from a system, disconnect both power cords. To reduce the risk that electrical shock could injure a person or damage the system, exercise caution when working in the unit even when only one power cord is connected.



### WARNING \_\_\_\_\_

To prevent a cabinet from tipping over and injuring a person or damaging the system, start installing systems from the bottom of the cabinet upward.



### WARNING \_\_\_\_\_

If you replace the modem cable supplied by Stratus, use a cable with a gauge of at least 26 AWG to prevent fire.



**WARNING** \_\_\_\_\_

To avoid fire, electric shock, and equipment breakdown, prevent water or foreign objects from getting into the equipment. Do not let water or foreign objects, such as pins or paper clips, enter the equipment.



**WARNING** \_\_\_\_\_

To prevent fire or current leakage, do not plug the power cord into a nonconforming outlet. Use a power outlet with appropriate voltage and power type, as specified in this guide.



**WARNING** \_\_\_\_\_

Do not install the equipment where you may need an extension cord. Use of an extension cord that does not meet the power specifications introduces a risk of overheating that could lead to a fire.



**WARNING** \_\_\_\_\_

Disconnect the power cords from the server or power source before you install or relocate the equipment. All voltage is removed only when the power cords are disconnected.



**WARNING** \_\_\_\_\_

Do not install or store the equipment in an unsuitable place. Install or store the equipment in a place that meets the requirements specified in this guide. Avoid the following conditions to avoid the risk of fire:

- Dust
- High humidity, such as a place near a boiler
- Direct sunlight
- Instability, such as places not stabilized against earthquakes

**WARNING** \_\_\_\_\_

Do not use or store this product in a corrosive environment.

Avoid using or storing this product in an environment which may contain corrosive gases. Such gases include, but are not limited to, sulfur dioxide, hydrogen sulfide, nitrogen dioxide, chlorine, ammonia or ozone.

Avoid installing this product in a dusty environment or one that may contain corrosive materials such as sodium chloride or sulfur.

Avoid installing this product in an environment which may contain excessive metal flakes or conductive particles in the air.

Such environments may cause corrosion or short circuits within this product, resulting in not only damage to this product, but also fire.

If there are any concerns regarding the environment at the planned site of installation or storage, please contact your CAC or your authorized Stratus service representative.

**WARNING** \_\_\_\_\_

Do not connect an interface cable while the server is connected to a power source. Make sure to power off the server and remove the power cord from the server or a power outlet before you install or remove any internal device, or connect or disconnect any interface cables to or from the server. Even if the server is powered off but still connected to a power source, touching an internal device, cable, or connector may cause an electric shock or a fire resulting from a short circuit.

**WARNING** \_\_\_\_\_

Do not disassemble, repair, or alter the server, except as described in the *Stratus ftServer 2510, 4410, and*

**6210 Systems: Operation and Maintenance Guide (R626).** There is a risk of an electric shock or fire as well as equipment malfunction if you do not observe the instructions in the *Stratus ftServer 2510, 4410, and 6210 Systems: Operation and Maintenance Guide (R626)*.



**WARNING** \_\_\_\_\_

Do not place any object on top of the server. The object may fall off and cause injuries, damage to hardware, or a fire.



**WARNING** \_\_\_\_\_

Do not leave the DVD tray ejected. Dust may enter the equipment and cause it to malfunction. The ejected tray may also become a cause of injuries.

## 安全注意事項



**WARNING** \_\_\_\_\_

不要插入未指定的插座。

電源請使用指定電壓及電源的壁式插座。使用未指定的電源會造成火災和漏電。請避免使用延長線安裝設備。



**WARNING** \_\_\_\_\_

不要插入未指定的插座。

電源請使用指定電壓及電源的壁式插座。使用未指定的電源會造成火災和漏電。請避免使用延長線安裝設備。如果連接與本產品電源規格不相符的電線，會因過熱而導致火災。

 **WARNING**

在安裝或移動設備之前請拔下電源插頭。

在安裝或移動設備之前要切斷設備電源，並拔下電源插頭。只有在拔下電源線後，設備的電壓才會消除。

 **WARNING**

不要安裝或存放在未指定的場所。

不要將本設備放置在如下場所和本書未指定的場所，有導致火災的危險。

- 灰塵較多的場所
- 熱水器旁等濕氣較高的場所
- 陽光直射的場所
- 不平穩的場所

 **WARNING**

不要在腐蝕性環境中使用或存放設備。

不要在有腐蝕性氣體（如二氧化硫、氯化硫、氮、氧、氯或臭氣等）的環境中使用或存放本產品。

不要將本產品安裝在灰塵較多或含有腐蝕性物質如氯化鈉或硫磺等的地方。

不要將本產品安裝在空氣中含有過量金屬碎末或傳導粒子的地方。

上述環境可能導致本產品腐蝕或短路，因而損壞產品，甚至引起火災。

對產品安裝或存放環境有任何疑問，請與經銷商或維修服務公司聯繫。

 **WARNING**

不要在插入插頭的狀態下進行信號線的連接。

在安裝/拆除可選配件或者拆裝信號線前將電源線從插座拔下。即使電源已切斷，在電源線連接的狀態下，可能因接觸信號線和介面產生觸電，或因短路而引起火災。

 **WARNING**

---

不要自行拆卸、修理或改造本伺服器。

除本書記載的情況外，不要進行拆卸、修理、改造。否則，不但可能導致設備不能進行正常運行，還有發生觸電和火災的危險。

 **WARNING**

---

不要將光碟機托盤拉出放置。

防止托盤中進入灰塵引起運轉錯誤。同時防止因碰撞等造成托盤損傷。

不要在設備附近使用行動電話或呼叫器。

在本產品附近時請關閉行動電話及呼叫器電源，防止因電波影響導致運轉錯誤。

---

## Chapter 2

# Electrical Power Planning

For information about planning appropriate AC electrical power for your system and its peripheral components, see:

- [“Redundant Power Sources” on page 2-1](#)
- [“AC Power and HVAC Service Requirements” on page 2-2](#)
- [“Selecting a UPS Unit for ftServer Systems” on page 2-9](#)
- [“Power Cord Summary” on page 2-15](#)
- [“Grounding Requirements” on page 2-17](#)

### Related Topic

- [Chapter 5, “Rack Configuration Planning”](#)

## Redundant Power Sources

ftServer systems require at least two separate and independent AC power sources—an *A-side* power source and a *B-side* power source—that provide power to the system’s power receptacles, labeled A and B, respectively. Either source must be capable of continuing to provide power if power to the other source is lost.

The A-side power source provides power to one side of each system and storage enclosure, as well as to components that do not require two sources of power, such as tape-drive enclosures and a monitor. If you use an uninterruptible power supply (UPS), the UPS is, in these standard, documented, configurations, the A-side power source.

The B-side power source provides power to the other side of each system and storage enclosure.

The wattage required from the A-side power source will always be equal to or greater than the wattage required from the B-side power source.

## AC Power and HVAC Service Requirements

From the *Stratus ftServer Systems: Peripherals Site Planning Guide* (R582), obtain the nominal input line voltage (volts AC) and frequency (Hz) required for optional, AC-powered components. In general, provide 100–240 VAC at 50 or 60 Hz for optional components. PDUs require 200–240 VAC at 50 or 60 Hz.

For detailed information about the plug types and lengths of the power cords provided with the system, see [“Power Cord Summary” on page 2-15](#).

The power service must be properly wired and grounded according to local standards and regulations. See [Appendix B, “Electrical Circuit and Wiring Information”](#) for more information.

### NOTE

Circuit breakers must provide a protective earth ground current at a maximum of 3.5 milliamperes (mA) for each AC power cord.

Use the following worksheets to determine AC power requirements for the site.

- In [Table 2-1](#), determine the power requirements at the A-side power source.
- In [Table 2-2](#), determine the power requirements at the B-side power source.
- In [Table 2-3](#), determine the power requirements for components outside of the cabinet. These components can share a power source with the A-side or B-side components.
- In [Table 2-4](#), determine the related HVAC requirements.

### To determine AC power requirements

Provide information in [Tables 2-1](#), [2-2](#), and [2-3](#) as follows:

1. In the Quantity column, write the number of each type of component.
2. Multiply the entry in the Quantity column by the number in the Watts column, and enter the result in the Watts Subtotal column.
3. Add the values in the Watts Subtotal column, and enter the sum on the bottom line. This value indicates the maximum power requirement for each power source.

**Table 2-1. Worksheet: Determining A-Side Power Requirements**

System Component	Quantity	Watts	Watts Subtotal
ftServer systems		x650	
Monitor unit <sup>†</sup>		x	
Tape drive enclosure <sup>†</sup>		x	
Storage enclosure <sup>†</sup>		x	
Fibre Channel switch <sup>‡</sup>		x	
User-supplied components			
<b>TOTAL A-SIDE POWER REQUIREMENTS</b>			

<sup>†</sup> See the *Stratus ftServer Systems: Peripherals Site Planning Guide (R582)* for the wattage of optional components you purchase from Stratus.

<sup>‡</sup> If you are using FC switches to connect the systems to storage enclosures, include on this line the power requirements for a FC switch. Two switches are required for fault-tolerant operation. Connect one switch to A-side power and the other switch to B-side power.

**Table 2-2. Worksheet: Determining B-Side Power Requirements**

System Component	Quantity	Watts	Watts Subtotal
ftServer systems		x650	
Storage enclosure		x	
Fibre Channel switch <sup>†</sup>		x	
User-supplied components			
<b>TOTAL B-SIDE POWER REQUIREMENTS</b>			

<sup>†</sup> If you are using FC switches to connect the systems to storage enclosures, include on this line the power requirements for a FC switch. Two switches are required for fault-tolerant operation. Connect one switch to A-side power and the other switch to B-side power.

**Table 2-3. Worksheet: Determining External Power Requirements**

System Component	Watts
Other peripheral components	
<b>TOTAL EXTERNAL POWER REQUIREMENTS</b>	

**To determine HVAC requirements**

1. Add together the values from the Total row of Tables 2-1, 2-2, and 2-3 and enter the value in the Total Watts column of Table 2-4.
2. Multiply the value in the Total Watts column by 3.41 and enter the number of BTUs in the BTUs/hr. Subtotal column.

**Table 2-4. HVAC Requirements**

Total Watts (From Tables 2-1, 2-2, and 2-3)	Convert to BTUs	BTUs/hr. Subtotal
	x 3.41 =	

**AC Power Outlet Requirements**

If you **do** use a pair of PDUs in the cabinet, use Tables 2-5 and 2-6 to determine the total number of power outlets required **outside the cabinet**.

1. In the Quantity column, write the number of each type of component.
2. Multiply the value in the Quantity column by the value in the Outlets column, and enter the total in the Subtotal column.
3. Add the values in the Subtotal column and enter the sum next to TOTAL NUMBER OF A-SIDE POWER OUTLETS and TOTAL NUMBER OF B-SIDE POWER OUTLETS.

**Table 2-5. Worksheet: A-Side External Power Outlet Requirements: PDUs Used**

Component	Quantity		Outlets	Subtotal
PDUs		x	1	
Other external components				
<b>TOTAL NUMBER OF A-SIDE POWER OUTLETS</b>				

**Table 2-6. Worksheet: B-Side External Power Outlet Requirements: PDUs Used**

Component	Quantity		Outlets	Subtotal
PDUs		x	1	
Other external components				
<b>TOTAL NUMBER OF B-SIDE POWER OUTLETS</b>				

If you do **not** use PDUs in the cabinet, use Tables 2-7 and 2-8 to determine the number of AC power outlets required **outside the cabinet**.

1. In the Quantity column, write the number of each type of component.
2. Multiply the value in the Quantity column by the value in the Outlets column, and enter the total in the Subtotal column.
3. Add the values in the Subtotal column and enter the sum next to TOTAL NUMBER OF A-SIDE POWER OUTLETS and TOTAL NUMBER OF B-SIDE POWER OUTLETS.

**Table 2-7. Worksheet: A-Side External Power Outlet Requirements: No PDUs**

Component	Quantity		Outlets	Subtotal
ftServer systems		x	1	
Storage enclosures		x	1	
LCD monitor units or external monitors		x	1	
Tape-drive enclosure		x	1	
Other peripheral components				
<b>TOTAL NUMBER OF A-SIDE POWER OUTLETS</b>				

**Table 2-8. Worksheet: B-Side External Power Outlet Requirements: No PDUs**

Component	Quantity		Outlets	Subtotal
ftServer systems		x	1	
Storage enclosures		x	1	
Other peripheral components				
<b>TOTAL NUMBER OF B-SIDE POWER OUTLETS</b>				

## Connecting a System Directly to Separate AC Sources

If you do not connect your ftServer system or PDUs to a UPS, provide two AC power sources that are as electrically independent of each other as the installation site allows.

At a minimum, the two power sources must be powered by separate circuit breakers (maximum of 20A) to AC power and, if possible, be independent of each other beyond that level. The more electrical separation between the two power sources, the less likely they will both fail at the same time. Due to redundancy in ftServer systems, power to either side of the system keeps the system in operation, although the system is no longer fault-tolerant with regard to power.

Figure 2-1 shows how to connect rack-mounted ftServer 2510, 4410, and 6210 systems directly to two separate AC power sources, Figure 2-2 shows how to connect a pedestal system directly to two separate power sources, and Figure 2-3 shows how to connect PDUs directly to two separate power sources.

Figure 2-1. Rack-Mounted System Connected Directly to AC Power

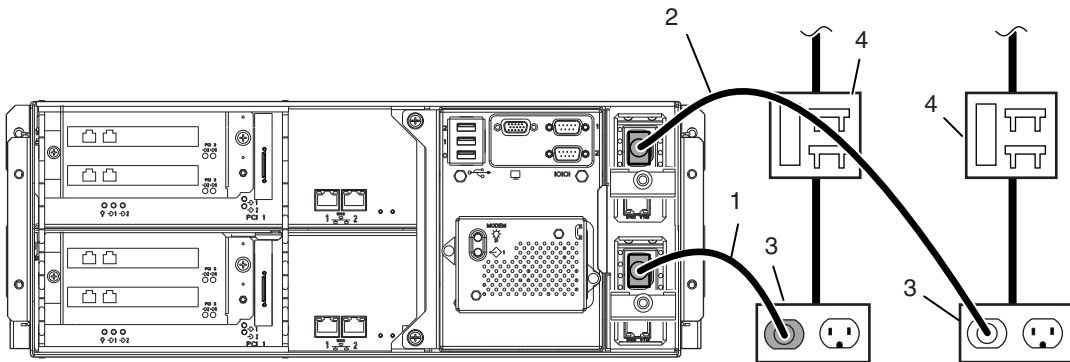

- 1 B-side power cord
- 2 A-side power cord
- 3 AC power outlets
- 4 Circuit breakers (maximum of 20A)

Figure 2-2. Pedestal System Connected Directly to AC Power

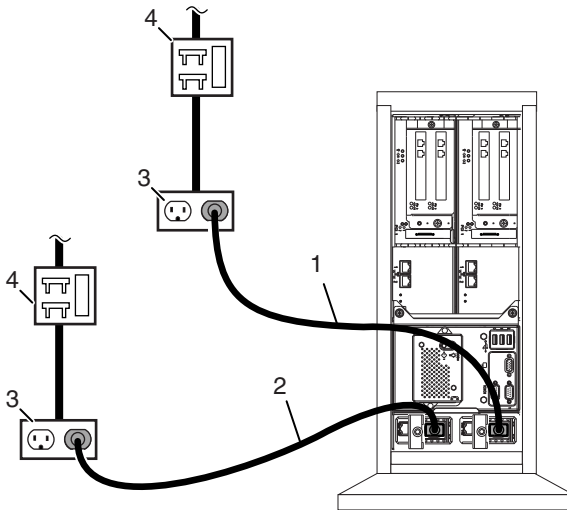

fhsys043

- 1 A-side system power cord
- 2 B-side system power cord
- 3 AC power outlets
- 4 Circuit breakers (maximum of 20A)

Figure 2-3. PDUs Connected Directly to AC Power

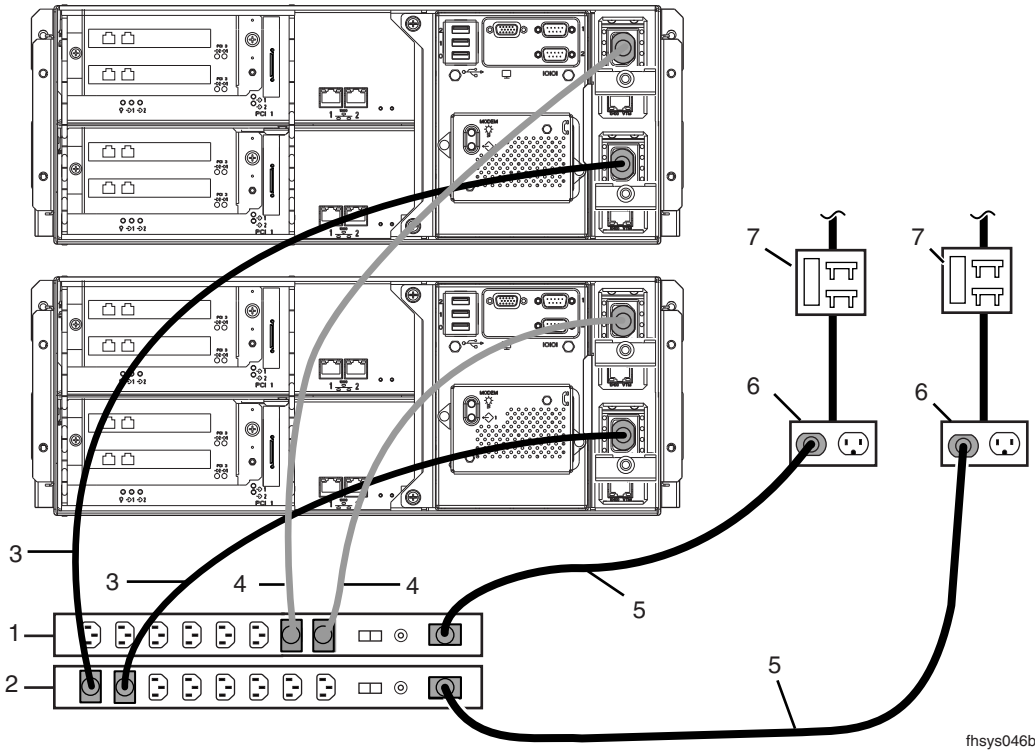

fhsys046b

- 1 A-side PDU
- 2 B-side PDU
- 3 B-side jumper cables
- 4 A-side jumper cables
- 5 PDU power cords
- 6 AC power outlets
- 7 Circuit breakers (maximum of 20A)

## Selecting a UPS Unit for ftServer Systems

Stratus does not sell or service UPS units. However, Stratus has qualified UPS models for use with ftServer 2510, 4410, and 6210 systems.

Use [Table 2-1](#) to determine the number of watts the A-side of your system requires and use [Table 2-9](#), [2-10](#), or [2-11](#) to select a UPS model.

### NOTES

---

1. Generally, system fault tolerance could be at risk if you use a UPS with systems that run ftSSS for VMware Infrastructure or ftSSS for the Linux operating system. These versions of ftSSS do not include the logic to decide whether the operating system should shut down in response to certain signals from the UPS, and the UPS may unnecessarily shut down the system.

If you have a situation that requires the use of a UPS (for example, if you do not have two separate power sources at the installation site), use the tables in this section to select an appropriate UPS, do **not** use UPS signaling, and contact the CAC or your authorized Stratus service representative for additional assistance.

2. Use of a UPS with systems that run ftSSS for VMware Infrastructure is additionally restricted because USB and serial communications are not available. USB is disabled and no serial ports are available. If you need assistance, contact the CAC or your authorized Stratus service representative.
3. Site planning information for the UPS in this document is of a general nature only. Do not rely exclusively on the UPS information in this document. [Contact APC at http://www.apcc.com](http://www.apcc.com) for detailed UPS specifications, documentation, and ordering information.

**Table 2-9. APC Symmetra Models for PDUs or for Multiple Systems**

Locale	APC Symmetra Model	Nominal Voltage	AC Power Output
North America	SYH2K6RMT-P1, SYH4K6RMT-P1, SYH6K6RMT-P1, SYA8K16RMP, or SYA12K16RMP  With SYA8K16RMP and SYA12K16RMP, also order AP7582, a rack PDU extender.	208V	120V or 208V
Japan	SYH2K6RMJ-P1, SYH4K6RMJ-P1, or SYH6K6RMJ-P1	200V	100V or 200V
Rest of the world	SYK2K6RMI, SYK4K6RMI, SYK6K6RMI, SYA8K16RMI, or SYA12K16RMI	230V	230V or 240V

**Table 2-10. APC UPS Models for a Single Rack-Mountable System**

Locale	Smart-UPS	Nominal Voltage	AC Power Output
North America	Model SUA1500RM2U	120V	120V
Japan	Model SUA1500RMJ2U	100V	100V
Rest of the world	Model SUA1500RMI2U	230V	120V or 208V

**Table 2-11. APC UPS Models for a Single Pedestal System**

Locale	Smart-UPS	Nominal Voltage	AC Power Output
North America	Model SUA1500	120V	120V or 208V
Japan	Model SUA1500J	100V	100V
Rest of the world	Model SUA1500I	230V	230V or 240V

## Communicating with a UPS over a Network

Use the following additional tools to enable a UPS and an ftServer system that runs the Windows operating system to communicate over the network:

- APC Network Management Card EX (APC part number AP9617)  
An APC Network Management Card EX is a standard component of the Symmetra UPS, but you must purchase the network card for the APC Smart-UPS.
- APC PowerChute® Network Shutdown for the ftServer system

When you install your ftServer system, download PowerChute Network Shutdown from APC, and install and configure the tool on the system, as described in the *Stratus ftServer System Software: Installation and Configuration for Windows Systems (R002W)*. PowerChute Network Shutdown monitors the UPS for an imminent power loss, and initiates a shutdown of the system before power is lost.

## Connecting Power to Systems, PDUs, and a UPS

When you plan for PDUs and a UPS, note the following:

- Only the top PDU is connected to the UPS.
- The bottom PDU is connected directly to an AC power main.
- The UPS can be connected to the same AC power main that the bottom PDU is connected to, or the UPS can be connected to another AC power main.

[Figure 2-4](#) shows how to connect rack-mounted systems to PDUs and the PDUs to UPS units.

Figure 2-4. Power Cord Connections for Systems, PDUs, and a UPS

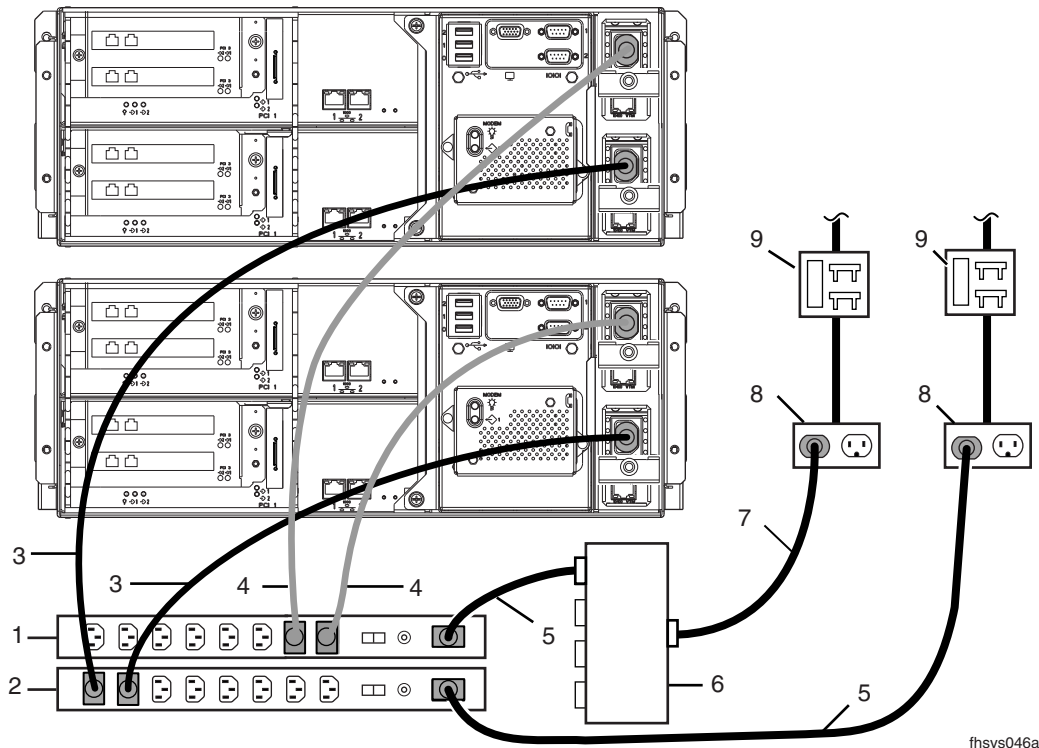

fhsys046a

- 1 A-side PDU
- 2 B-side PDU
- 3 B-side system power cables (black)
- 4 A-side system power cables (gray)
- 5 PDU power cords
- 6 UPS
- 7 UPS power cord
- 8 AC power outlets
- 9 AC power (mains) distribution circuit breaker (maximum of 20A)

## Connecting a System Directly to a UPS

You can connect the A-side power connectors of your system directly to a UPS, as shown in [Figure 2-5](#) and [Figure 2-6](#).

**Figure 2-5. Rack-Mountable Systems: A-Side Power Connected Directly to a UPS**

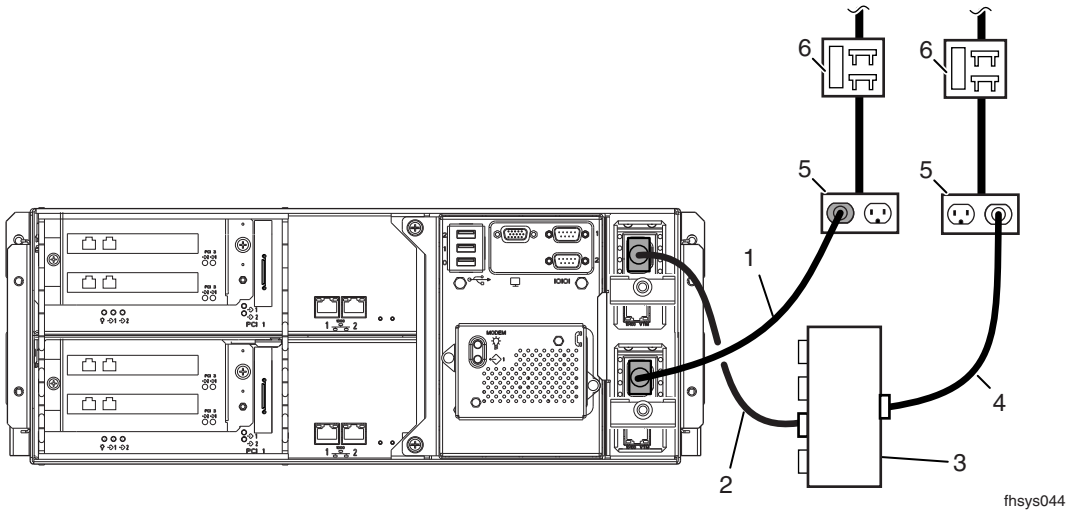

- 1 B-side system power cord
- 2 A-side system power cord
- 3 UPS
- 4 UPS power cord
- 5 AC power outlets
- 6 Circuit breakers (maximum of 20A)

Figure 2-6. Pedestal Systems: A-Side Power Connected Directly to a UPS

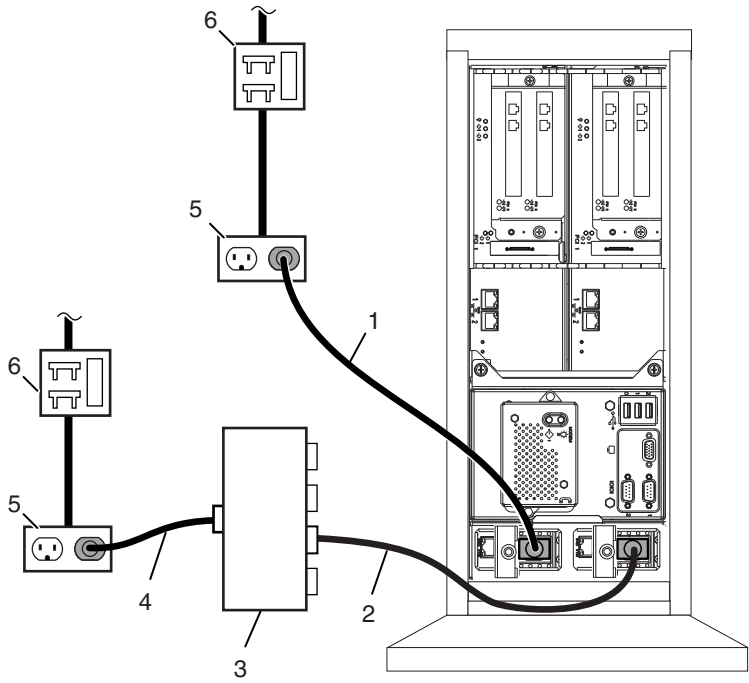

fhsys045

- 1 B-side system power cord
- 2 A-side system power cord
- 3 UPS
- 4 UPS power cord
- 5 AC power outlets
- 6 Circuit breakers (maximum of 20A)

## Power Cord Summary

Stratus supplies tested and approved AC power cords for the following components:

- [ftServer systems and peripheral components](#)
- [PDUs](#)



### WARNING

**Place all power cords out of the way of foot traffic.**

Power cords described as Domestic are made with American Wire Gauge (AWG) cordage and are intended for use in North America. Refer to UL 62 and CSA C22.2, No. 49. All other power cords are made with International Harmonized cordage and are intended for use in the specified countries, and other countries that use that standard.

## Power Cords for ftServer Systems and Peripheral Components

[Table 2-12](#) lists the available power cords that connect ftServer systems and peripheral components directly to an AC power source (not to a PDU or to a UPS).

[Table 2-13](#) lists the available power cords that connect ftServer systems to [qualified UPS models](#) from APC.

**Table 2-12. Power Cords from ftServer Systems and Peripheral Components to AC Power**

Marketing ID	Plug Type	Rating	Length	Locale
B50101F	NEMA 5-15, UL/CSA approved	15A/127V	7 ft	North America (Domestic)
B50104F	NEMA 5-15, UL/CSA approved	15A/127V	15 ft	North America (Domestic)
B50112F	CEE 7 VII	16A/250V	4.5m	Europe (Continental)
B50116F	BS 1363/A,	13A/250V	4.5m	United Kingdom
B50124F	AS/NZS 3112:1993	10A/250V	4.5m	Australia
B50140F	SEV 1011-S24507	10A/250V	4.5m	Switzerland
B50152F	SABS164-1:1992 ZA/3	13A/250V	4.5m	South Africa/India
B50153F	IEC 60309, TUV approved	16A/250V	4.5m	International, locking power cord
B50160F	NEMA 5-15, PSE approved	15A/127V	15 ft (4.5m)	Japan

**Table 2-12. Power Cords from ftServer Systems and Peripheral Components to AC Power** (*Contin-*

Marketing ID	Plug Type	Rating	Length	Locale
B50161F	NEMA L6-20	20A/250V	15 ft (4.5m)	North America and Japan locking power cord
B50162F	GB1002-1996, CCC approved	10A/250V	4.5m	China
B50173F	NEMA 5-15, BSMI approved	10A/125V	4.5m	Taiwan

**Table 2-13. Power Cords Between ftServer Systems or Storage Systems and a UPS**

Marketing ID	Plug Types	Rating	Length	Locale
B50104F-15	NEMA 5-15 to IEC 60320 C13	16A/120V	15 ft	North America
B50161F-45M	NEMA L6-20 to IEC 60320 C13	20A/250V	15 ft (4.5m)	North America and Japan locking power cord
B50301F-45M	IEC 60320 C14 to IEC 60320 C13	10A/250V	4.5m	International

## PDU Power Cords

The PDU supplies power to ftServer systems. [Table 2-14](#) lists the available power cords that connect PDUs directly to an AC power source.

[Table 2-15](#) lists the available power cords that connect PDUs to a UPS.

[Table 2-16](#) describes the gray and black power (*jumper*) cables that are provided to connect ftServer systems to PDUs.

**Table 2-14. Power Cords to Connect PDUs Directly to AC Power Mains**

Marketing ID	Plug Type	Rating	Length	Locale
B50154F	IEC 60320 C19 to IEC 60309	20A/250V	15 ft	International
B50171F	IEC 60320 C19 to NEMA L6-20P PSE-approved	16A/250V	4.5m (15 ft)	North America and Japan

**Table 2-15. AC Power Cords to Connect PDUs to a UPS**

Marketing ID	Plug Type	Rating	Length	Locale
B50171F	IEC 60320 C19 to NEMA L6-20P PSE-approved	16A/250V	4.5m (15 ft)	North America and Japan
B52700F-45M	IEC 60320 C19 to IEC 60320 -C20	20A/250V	4.5m	International

**Table 2-16. System Power (*Jumper*) Cables to Connect ftServer Systems to PDUs**

Marketing ID	Plug Type to System	Plug Type to PDU	Rating	Length
B50502F	IEC 60320 C13	IEC 60320 C14	10A/250V	2.0m
B50503F	IEC 60320 C13	IEC 60320 C14	10A/250V	2.0m

## Grounding Requirements



### WARNING

**Incorrect grounding can cause severe personal injury and extensive equipment damage.**

The ftServer system obtains an earth reference ground over independent ground connections to the cabinet frame. Ensure that a high-integrity safety-ground conductor is installed as part of the wiring system.

See “[Grounding Considerations](#)” on page B-1 for a more complete discussion of ftServer system grounding.



---

## Chapter 3

# Space Planning

For information about planning sufficient space for your ftServer system, see:

- [“Room Requirements” on page 3-1](#)
- [“Planning for Cables” on page 3-3](#)

### Room Requirements

To ensure that the installation site provides a properly equipped, cooled, and sized environment, make sure that the site:

- Provides clearances for air circulation, opening cabinet doors, removing cabinet panels, and servicing the system from the front and rear.

Locate the front and rear of the system at least 2.5 feet (ft) (0.76 meters (m)) away from walls and other obstructions.

- Maintains reasonable temperature and humidity levels and has a thermometer and humidistat to monitor room temperature and humidity.

See [Chapter 2, “Electrical Power Planning”](#) for detailed information about HVAC planning.

- Is as free of dust as possible, meeting, at a minimum, ISO 14644-1 class 8 standards for a clean-room environment.

Dust buildup in the system can impede air circulation and heat transfer, causing components to become less reliable as the ambient temperature rises.

Fans clogged by dust fail to expel hot air, causing circuit boards to overheat and fail.

Dust on circuit boards raises the temperature, thus reducing the component's mean time between failure (MTBF).

Dust circulating in the room increases the risk of fire within the room by providing potential combustible material within the environment.

Dust contamination on tape devices causes mis-reads and -writes, leading to failure of attempts to back up and restore data.

- Has sufficient floor space for external components.
- Provides a table or desktop for external devices such as a telephone, external monitor, keyboard, and mouse, and for ESX Server systems, a management PC.

For ESX Server systems, provide a monitor, keyboard, and mouse to install VMware Infrastructure and ftSSS for VMware Infrastructure. For access to the ftServer system after you install the operating system and ftSSS, arrange for a serial connection from a management PC to the ftServer system

Each of these devices requires table or rack space. You **cannot** place a peripheral component on top of a system cabinet.

- Allows the system and peripheral devices to be placed within the room so that power cords and communications cables will reach their respective power receptacles, telephone jacks, and other connection points.
- Provides communications cable connectors or patch panels as needed.
- Provides two electrically separate grounded AC wall outlets, within reach of the power cords from the system or PDUs, and, if used, UPS units. Detachable power cords are 12 ft. (3.65m). If the power cord must be hard-wired, consult an electrician to plan the length of the power cord.
- Provides grounded AC wall outlets for external components that do not connect to a PDU.
- Provides cutouts in the floor for routing cables, if the site has an elevated floor.
- Contains space for future expansion.



**CAUTION** \_\_\_\_\_

Do not place the system in an area of high electrostatic discharge. Static electricity may damage components. Do not locate components near transformers or other electromagnetic devices.

See [Appendix A, "System Specifications"](#) and *Stratus ftServer Systems: Peripherals Site Planning Guide (R582)* for the dimensions of system components.

## Planning for Cables

To accommodate cables from your system, make sure to provide:

- One or two telephone lines:
  - One telephone line for use when calling for service
  - One telephone line for the ASN modem, if used
- Ethernet jacks, switches, or hubs, as needed
- Two electrically separate grounded AC wall outlets, or a UPS and a wall outlet, within reach of the power cords from the system or PDUs, and additional outlets for any components that do not connect to a PDU
- For optional components, AC wall outlets within reach of the power cords from the components, or use PDUs

Make sure that cables you plan to connect to the system are long enough to reach between the system and external components or connections. For information about specific cables and power cords, see the following:

- [“Power Cord Summary” on page 2-15](#)
- [Chapter 4, “Communications Line Planning”](#)
- [“Monitor Requirements” on page 6-4](#)
- *Stratus ftServer Systems: Peripherals Site Planning Guide (R582)* for information about cable lengths for peripheral components



---

# Chapter 4

## Communications Line Planning

Make sure that you plan the locations of your ftServer system and its external components so that all communications and data cables will reach their connection points.

This chapter contains the following sections:

- “SCSI Connections” on page 4-2
- “Fibre Channel Connections” on page 4-3
- “Ethernet Cables” on page 4-5
- “Serial (Null Modem) Cable Connections” on page 4-8
- “Telephone Line Connections” on page 4-8
- “Site Planning for Systems in an ftGateway Group” on page 4-9

### NOTES

---

1. Software upgrade services are available from [Stratus Professional Services](#). For a list of available services, see <http://www.stratus.com/services/ps/offerings.htm>.
2. If you have a unique network requirement, contact [Stratus Professional Services](#). For a list of available services, see <http://www.stratus.com/services/ps/offerings.htm>.
3. See the *Stratus ftServer Systems: PCI Adapter Guide* (R461) for more information about the adapters Stratus supplies for your ftServer system.

## SCSI Connections

U527 Ultra320 SCSI PCI Adapters, in the CPU-I/O enclosures, provide connection points to tape drives from your Linux or Windows system.

Table 4-1 lists the available SCSI cables and Figure 4-1 illustrates the connections from two systems to a tape drive enclosure with two tape drives.

**Table 4-1. Single-Initiated SCSI Tape Cables**

Length	Part number
10 ft (3.05m)	AW-001046-01
30 ft (3.05m)	AW-001046-02

**Figure 4-1. SCSI Connections to Tape Drives**

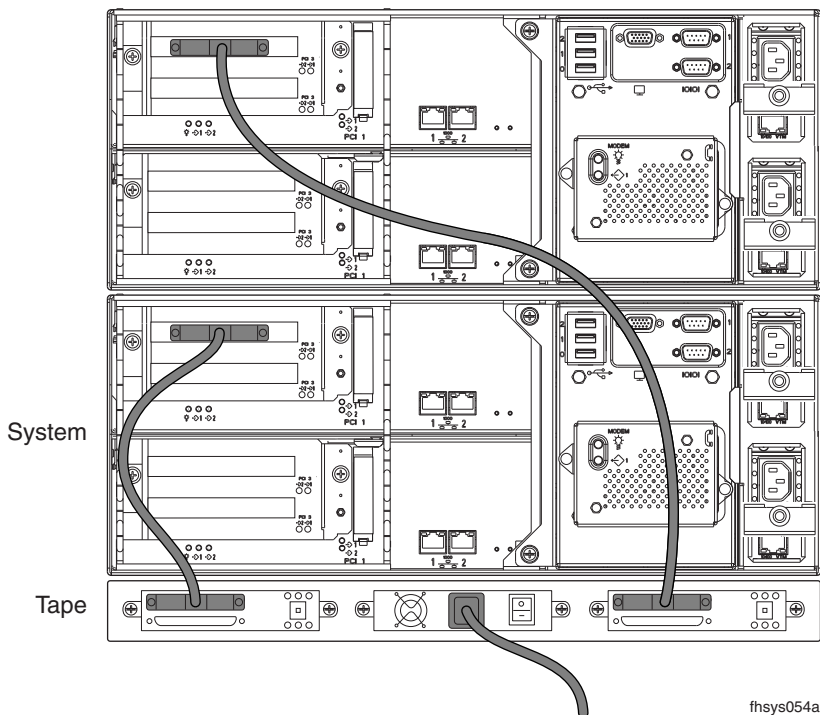

## Fibre Channel Connections

ftServer systems support connections to ftScalable Storage systems and EMC CLARiiON and Symmetrix storage systems. Optical Fibre-Channel host bus adapters (HBAs) in the CPU-I/O enclosures provide connection points to these storage enclosures.

ftSSS for the Windows Operating System and ftSSS for the Linux Operating System support the following attachments:

- Direct attachment from one or two ftServer systems to the RAID controller tray of an ftScalable Storage system, to the storage processors of an EMC CLARiiON storage system, or to the HBA of a Symmetrix storage system
- Attachment through a storage area network (SAN) from multiple ftServer systems to ftScalable Storage systems or EMC storage systems

ftSSS for the Linux Operating System supports also directly-attached or SAN-attached HP StorageWorks EVAs.

ftSSS for VMware Infrastructure supports attachment through a SAN from multiple ftServer systems to ftScalable Storage systems or EMC storage systems.

A pair of HBAs is teamed for fault tolerance. The adapters are single-ported and each member of the pair is installed in a different CPU-I/O enclosure: one in the top enclosure and the other in the bottom enclosure. The *Stratus ftServer Systems: Peripherals Site Planning Guide* (R582) lists the optical Fibre Channel HBAs supported by each operating system.

[Table 4-2](#) lists the available optical Fibre Channel cables.

**Table 4-2. Optical Fibre Channel Cables**

Length	Part number
6.5 ft (2m)	AW-B90000-020
32.8 ft (10m)	AW-B90000-100
98.4 ft (30m)	AW-B90000-300

For detailed instructions for making the Fibre Channel connections, see the one of the following:

- The *ftScalable Storage: Getting Started Guide* (R601), where you can also see an illustration of multiple ftServer systems connected to an ftScalable Storage controller tray (that configuration is not shown here)
- The documentation for your EMC storage system

The following illustrations are provided to help you plan a site for ftServer systems and storage enclosures.

- **Figure 4-2** illustrates Fibre Channel connections from a single system to a switch, and from the switch to the ftScalable Storage controller tray. Connections to EMC storage systems through a SAN are similar.
- **Figure 4-3** illustrates Fibre Channel connections directly between an ftServer system and an ftScalable Storage controller tray. Direct connections from Windows ftServer systems and an EMC storage system are similar.

**Figure 4-2. Fibre Channel Connections to an ftScalable Storage System Using Switches**

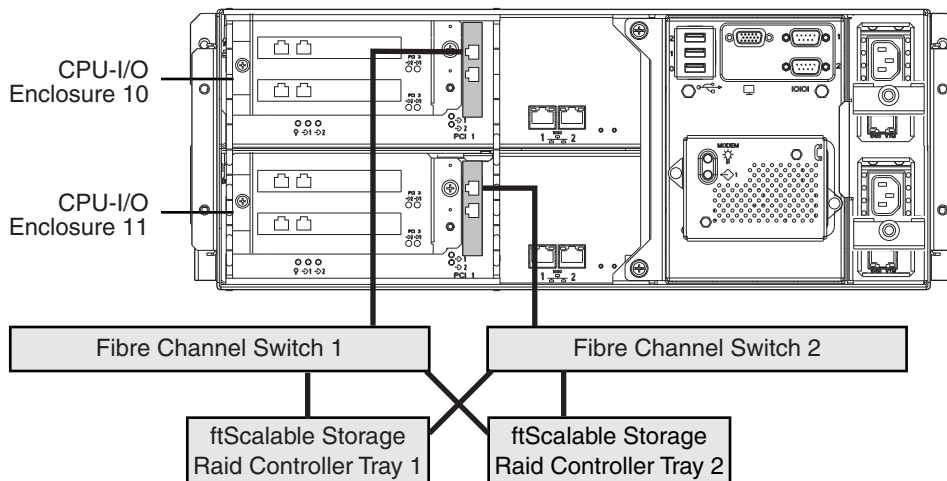

ftsys052

Figure 4-3. Direct-Attach Fibre Channel Connections to an ftScalable Storage System

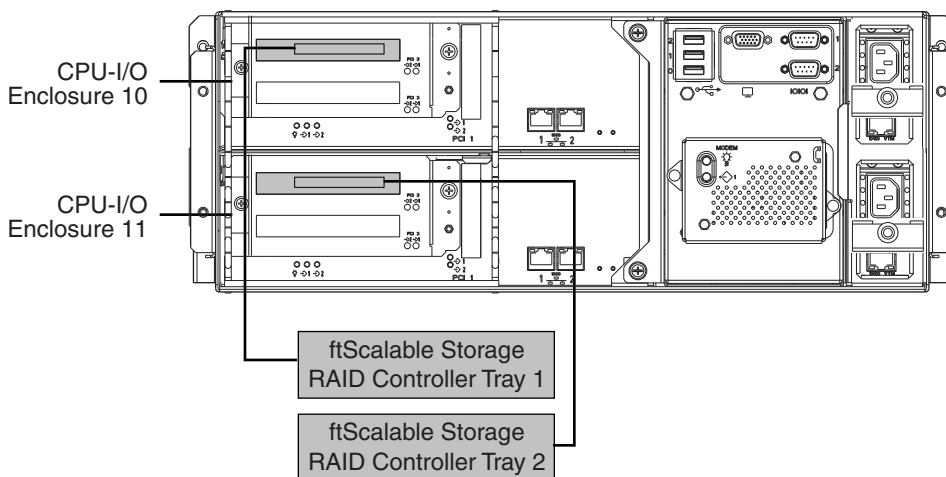

fhsys053

## Ethernet Cables

In addition to the Ethernet cables listed in this section, you must also plan to provide network connection points. If your system will have VTMs installed, consider providing a maintenance network to connect the VTMs to a management PC from which you can access the VTM's Web interface.



### WARNING

**Make sure network cables can be routed out of the way of foot traffic.**

### NOTE

ftSSS for VMware Infrastructure does not support VTMs.

You will need Ethernet cables for the following connections:

- From two or four embedded Ethernet ports on the system and Ethernet ports on U574F-LC or U575F Ethernet adapters to network connection points

**NOTE** \_\_\_\_\_

Two Ethernet ports are typically paired and teamed in software for fault tolerance. Each member of the pair requires an Ethernet cable.

- From each ftScalable Storage RAID controller tray, if present, to a network connection point, for Web management of ftScalable Storage systems
- From a management PC to a network connection point, for Web management of ftScalable Storage systems

The same network must provide access to the RAID controllers on the ftScalable Storage RAID controller tray from the PC.

Table 4-3 describes the cables you must supply for network connectivity. Be sure to provide cables of sufficient length for the distance between the system and a wall jack or hub.

**Table 4-3. Customer-Supplied Ethernet Cables**

Component	Quantity	Marketing ID/Cable Length	Cable Type
VTM Ethernet port <sup>†</sup>	2	N/A. You must supply these cables.	24 AWG Unshielded Twisted Pair (UTP) EIA/TIA-Verified, Category-3 or Category-5 wire, with RJ-45 modular connectors terminated with pair-wiring adhering to the EIA/TIA 568-A or EIA/TIA 568-B standard.
System Ethernet port	2 or 4		
U575F Two-Port, Copper, 10/100/1000 Base-T Ethernet PCI Adapter (gigabit copper adapter for servers)	1 for each port, typically teamed for fault tolerance	The maximum allowable distance from these ports to a switch or a hub is 328 ft (100m).	For connections to an Ethernet hub or switch, provide a straight-through cable.  For 100- or 1000-Mbps (fast Ethernet) operation, provide full-duplex, or Category-5 Ethernet cables.

**Table 4-3. Customer-Supplied Ethernet Cables** (Continued)

Component	Quantity	Marketing ID/Cable Length	Cable Type
U574F-LC Dual-Port 1000Base-SX Fiber Ethernet PCI Adapter (gigabit fiber-optic adapter for servers)	1 for each port, typically teamed for fault tolerance	N/A. You must supply these cables.  The maximum distance between the U574F-LC PCI adapter and a switch is 902 ft (275m).	Multimode, 62.5- or 50-micron, DUAL fiber cable with LC-type connectors to the PCI adapter, and connectors on the other end that are compatible with your site network switch.
ftScalable Storage RAID controller tray <sup>†</sup>	3: two for each controller tray and one to a management PC	N/A. You must supply these cables.	24 AWG Unshielded Twisted Pair (UTP) EIA/TIA-Verified, Category-3 or Category-5 wire, with RJ-45 modular connectors terminated with pair-wiring adhering to the EIA/TIA 568-A or EIA/TIA 568-B standard.  For connections to an Ethernet hub or switch, provide a straight-through cable.  For 100-Mbps (fast Ethernet) operation, provide full-duplex, or Category-5 Ethernet cables.

<sup>†</sup> Your system may not contain **VTMs**, which are optional in Windows and Linux systems, and not available in ESX Server systems.

<sup>‡</sup> ftScalable Storage systems are optional for Windows and Linux systems. Unless you will connect an ESX Server system to an EMC storage system, an ftScalable Storage system is required. If you do connect a system to an EMC storage system, consider its Ethernet network requirements in your site planning.

## Serial (Null Modem) Cable Connections

To connect ESX Server systems to a management PC, do one of the following:

- Locate the system and management PC within reach of the null modem cable that connects them.
- Locate the system so that the null modem cable can reach a serial-port concentrator that is connected to a management PC.

Table 4-4 describes the required null modem cable.

**Table 4-4. Null Modem Cables**

Component	Cable Description	Marketing ID Length
Management PC to the system backplane	One DB-9 female to DB-9 female asynchronous null modem cable for connecting the PC console to the COM2 port on the system	N/A. You must provide this cable; obtain the length for your planning

## Telephone Line Connections

The system requires up to two telephone cables, and related connection points:

- One telephone line for use when calling for service
- One analog telephone line to connect the ASN modem, if used, to a telephone connection point

A 7-ft (2.13m) telephone cable is shipped with the modem assembly.<sup>1</sup>

### NOTE

A dedicated phone line provides the most reliable service for ASN connections. ASN calls routed through a PBX might be slow due to the load on the PBX, or might not complete successfully because the calls can become disconnected. If you must use a PBX, do not route the telephone extension through a switchboard; instead, provide a direct-dial analog number.

---

<sup>1</sup> The telephone cable is not shipped with orders destined for the Republic of Korea.

If no modem is installed, a second telephone line is not necessary. A modem is not necessary in the following situations:

- If your system will connect to a network with Internet access, you may choose to use the Internet to send alarms to the ASN and allow the CAC or your authorized Stratus service representative to connect to your system over the Internet for troubleshooting.
- If you implement ftGateway groups, only one system in the group requires a modem. See [“Site Planning for Systems in an ftGateway Group”](#) for more information.

NOTE \_\_\_\_\_  
ftSSS for VMware Infrastructure does not support VTMs or ftGateway groups.

## Site Planning for Systems in an ftGateway Group

NOTE \_\_\_\_\_  
ftSSS for VMware Infrastructure does not support ftGateway groups.

Multiple ftServer systems at a site can share a single telephone connection to the ASN by implementing an *ftGateway group*. Unless VTMs are installed in each system, the systems in the group must be connected to a **single** physical Ethernet subnetwork. One system acts as a *gateway* for ASN connectivity. This gateway system requires an analog telephone line that connects to the modem. Other systems in the ftGateway group, called *gateway slaves*, connect to the gateway system over the network. In this case, Ethernet connections are required for each system, but only two analog telephone lines for each ftGateway group are required.

Members of an ftGateway group:

- Are limited to a maximum of 20 ftServer systems.
- Are limited to systems running the Windows or Linux operating system

NOTE \_\_\_\_\_  
You cannot mix systems that run the Linux operating system and systems that run the Windows operating system in the same ftGateway group.

- Must connect to the same subnetwork through system Ethernet ports, ports of Ethernet adapters, or VTMs. An ftGateway group can consist of one of the following:
  - Slave systems that run the Windows operating system with no remote management adapter in a group with an ftGateway system that has VTMs

NOTE \_\_\_\_\_

Systems that run the Linux operating system and that are members of an ftGateway group must contain VTMs.

- Slave systems that have VTMs in a group with an ftGateway system that has VTMs

Using VTMs provides the highest level of manageability by allowing the system to be serviced even when the operating system is not operational.

NOTES \_\_\_\_\_

1. You cannot mix VTMs and ftServer Access Adapters in the same ftGateway group. ftServer Access Adapters are system management adapters used in earlier models of ftServer systems.
2. Make sure that only layer-1 and layer-2 devices separate the gateway and slave systems. During a connection, the gateway system assigns the slave system a temporary IP address from an IP address range reserved by Stratus and uses that address for all traffic.

---

# Chapter 5

## Rack Configuration Planning

For information about planning a rack configuration, see:

- [“Using PDUs” on page 5-1](#)
- [“Determining PDU Requirements” on page 5-2](#)
- [“Sample PDU Usage Calculation” on page 5-4](#)

### Using PDUs

Server systems have two power receptacles. Correspondingly, two power distribution units (PDUs) provide power to the receptacles.

Use of PDUs is optional unless you have a support agreement with Stratus. If you do have a support agreement with Stratus, use pairs of PDUs to provide AC power to systems and components in a cabinet **if six or more power cords would otherwise exit from the cabinet.**

The A-side (top) PDU provides power to:

- The A-side of each system
- A rack-mounted LCD monitor unit
- A storage enclosure
- Any rack-mounted tape drives

The B-side (bottom) PDU provides power to the other side of each system and to the second side of a storage enclosure.

Because the A-side PDU always uses at least as many power cords and consumes at least as much power as the B-side PDU, plan the cabinet configuration so that the A-side PDU can support the configuration.

NOTES \_\_\_\_\_

1. Connect each PDU to a separate AC power source.
2. Install a maximum of two pairs of PDUs in a rack.

Use the information in “[Determining PDU Requirements](#)” on page 5-2 to plan the rack configuration for your ftServer system. “[Sample PDU Usage Calculation](#)” on page 5-4 shows how to use the information you gather for planning the rack configuration.

## Determining PDU Requirements

Using the nominal voltage rating of the power receptacle at your site and the total wattage of the components that will draw power from the A-side PDU, complete the information in Tables 5-1 and 5-2. This information will help you determine the current that the ftServer systems and rack-mounted components will draw and whether you need a second pair of PDUs.

### To complete Table 5-1

1. Obtain the voltage available at your location. Consult a facilities manager at your site to make sure you know the correct voltage.
2. For each type of component you plan to place in the rack, calculate the required current, as follows: Divide the wattage of the element, listed in the Watts column of [Table 5-1](#), by the voltage available at your site. Multiply the result by 1.25 and enter the value in the **Current** column.

**Table 5-1. Current and Rack-Space Requirements**

Component	Watts	Current	Rack Space
ftServer system	650		4U
1U LCD monitor unit†			1U
Tape-drive enclosure†			
Disk-storage enclosure†			

† See the *Stratus ftServer Systems: Peripherals Site Planning Guide* (R582) for the wattage and rack requirements of your monitor, tape drive, and disk-storage solutions.

**To complete Table 5-2**

1. In column 1, write the names of each system or component in the rack. If you have more than one system, use a row for each system.
2. In column 2, write the cumulative number of rack units (Us): Add the number of Us (see Table 5-1) for the component to the value in the space above and write the result.
3. In column 3, write the cumulative number of outlets required. For each component, add 1 to the value in the space above and write the result.
4. In column 4, write the cumulative current required. For each component, add the current for the component, which you entered in Table 5-1, to the value in the space above and write the result.

You need another pair of PDUs if the cumulative number of outlets exceeds 8 or if the cumulative current exceeds 15A. Use the information in column 2 to plan the size and number of racks required.

**Table 5-2. Calculating A-Side PDU and Rack-Space Requirements**

1. Component	2. Cumulative Space Used	3. Cumulative Number of Outlets	4. Cumulative Current (A)
PDU Pair	2U	0	0.00

## Sample PDU Usage Calculation

Table 5-3 shows how to use the information from Table 5-1 to calculate the required rack space and the current when the PDU is connected to a NEMA L6-20R receptacle in the United States, with a power voltage of 208V.

**Table 5-3. Sample: Current and Rack-Space Requirements**

Component	Watts	Current (A)	Rack Space
ftServer system	650	3.91	4U
1U LCD monitor unit	54	0.12	1U
EC-SL1AA-YF tape drive enclosure	80	0.48	2U
ftScalable Storage system	400	2.40	2U

Table 5-4 and the explanation which follows show how to use the information from Table 5-3 to determine when you need to buy an additional pair of PDUs or calculate the size and number of cabinets you need.

**Table 5-4. Sample: Calculating A-Side PDU and Rack-Space Requirements**

1. Component	2. Cumulative Space Used (U)	3. Cumulative Number of A-Side Outlets	4. Cumulative Current (A)
PDU pair	2	0	0.00
ftServer system	6	1	3.91
1U LCD monitor unit	7	2	4.23
Tape drive enclosure	9	3	4.71
ftScalable Storage system	11	4	7.12
ftServer system	15	5	11.02
ftServer system	19	6	14.93
PDU pair	21	0	0
ftServer system	25	1	3.91

In the calculations in [Table 5-4](#), components were added one by one, calculating:

- The total current demanded by the components
- The total space used in the rack
- The total number of outlets required

In this example, two PDUs can provide enough current for the LCD monitor unit, one tape drive enclosure, one ftScalable Storage system, and three ftServer 2510, 4410, or 6210 systems. This set of components consumes 14.93 amperes; adding another system would increase the consumption to 17.94 amperes. The configuration also occupies 6 outlets in the A-side PDU and 19U of rack space.

To add any more components, you require another pair of PDUs.

For information about planning a rack configuration, see:

- [“Using PDUs” on page 5-1](#)
- [“Determining PDU Requirements” on page 5-2](#)
- [“Sample PDU Usage Calculation” on page 5-4](#)



---

## Chapter 6

# Cabinet and Monitor Requirements

For requirements related to providing your own cabinet and monitor, see:

- [“Cabinet Requirements” on page 6-1](#)
- [“Monitor Requirements” on page 6-4](#)

## Cabinet Requirements

If you are providing your own cabinet for an ftServer system, make sure the cabinet contains a rack that is 19 inches (in.) wide and that meets the Electronic Industries Association (EIA) 310-D standard.

In general, consider the following factors during your site planning for systems in cabinets:

- **Elevated Operating Ambient Temperature**—If installed in a closed or multi-unit rack assembly, the operating ambient temperature of the rack environment may be greater than room ambient. Therefore, consideration should be given to installing the equipment in an environment compatible with the maximum ambient temperature (T<sub>ma</sub>) specified by the manufacturer.
- **Reduced Air Flow**—Installation of the equipment in a rack should be such that the amount of air flow required for safe operation of the equipment is not compromised.
- **Mechanical Loading**—Mounting of the equipment in the rack should be such that a hazardous condition is not achieved due to uneven mechanical loading.
- **Circuit Overloading**—Consideration should be given to the connection of the equipment to the supply circuit and the effect that overloading of the circuits might have on overcurrent protection and supply wiring. Appropriate consideration of equipment nameplate ratings should be used when addressing this concern.

Make sure that the cabinet meets the following requirements:

- The cabinet can support the weight of all the components you plan to install in it. [Appendix A](#) and the *Stratus ftServer Systems: Peripherals Site Planning Guide* (R582) provides the weights of components supplied by Stratus.

- The cabinet contains two front and two rear vertical EIA rails, one in each corner of the cabinet, that have the EIA **universal** square-hole pattern as defined in the EIA 310-D specification.
- The front vertical rails extend at least 0.5 in. (1.27 centimeters (cm)) beyond the inside edge of the accessory leg, if present, to allow the mounting rails to be fitted. See [Figure 6-1](#).
- The distance between the front vertical rails and the inside of the front door is at least 3.0 in. (7.62 cm).
- The distance between the rear of the system chassis and the inside of the rear door is at least 6.0 in. (15.24 cm).
- The distance between the front and rear vertical rails is between 24.5 in. and 30 in. (62.23 cm and 76.20 cm, respectively).
- The vertical mounting rails accept 10-32 cage nuts and mounting hardware.
- The vertical mounting rails are plated, or some other method is used to ensure continuity for grounding between installed equipment.
- Cable-management brackets are provided to support and constrain data and power cords so that the cables do not interfere with air flow out of the rear of the enclosures, and so that the connectors do not disconnect or break.
- To prevent stray voltages, all components are grounded together through the vertical mounting rails to the cabinet frame, and then to local building ground. To ensure signal quality, use a grounding cable for local building ground.
- There is a plan for maintaining cables and wires to the cabinet by either running them under the floor or placing them overhead in an overhead cable tray.
- Air flows through the cabinet from front to back.
- Air does not recirculate within the cabinet.
- Filler panels cover any unused rack space to prevent air recirculation.
- Blockers are installed between the vertical mounting rails and the side panels at the rear of the cabinet.
- Vents are evenly distributed on the front and rear doors and make up at least 63% of the surface area.

NOTE \_\_\_\_\_

If your cabinet does not have vented front and rear doors, you can remove the doors from the cabinet while your ftServer system is operating.

- The final installation conforms to all emission, immunity, safety, and other applicable regulations.

Figure 6-1 shows the required rail clearance between the front vertical rails and the inside edge of an accessory leg.

Figure 6-1. Rail Clearance

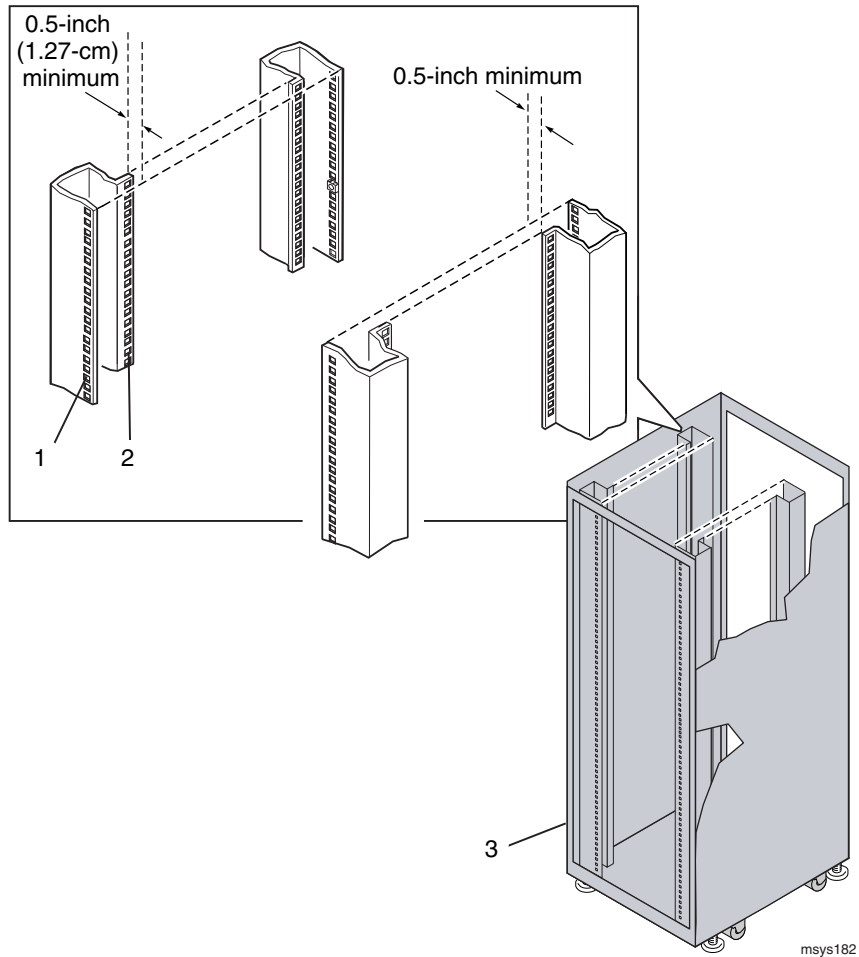

- 1 Front vertical EIA rail
- 2 Accessory leg
- 3 Front of cabinet

## Monitor Requirements

If you are using a monitor that is not supplied by Stratus, make sure that:

- The monitor accepts universal 100–240 volts AC (VAC), 50/60 Hertz (Hz) power.
- The VGA cable has a 15-pin D-sub connector.
- The power cord for the monitor is long enough to reach the power source.
- The plug type on the power cord is compatible with the external power source at the site.

ftSSS for VMware Infrastructure does not support the use of a directly-attached VGA monitor, mouse, and keyboard, except during installation of ESX Server and ftSSS. See [“Management PC Requirements”](#) for information about the alternative method for directly connecting to the ESX Server system.

## Management PC Requirements

For ESX Server systems, you must provide a computer to be the management PC. The computer must have:

- A serial port
- Terminal emulation software installed. The emulator must be able to transmit keystrokes such as F1 and F2 to interact with the BIOS.

A serial cable connects the management PC to the ftServer system’s COM2 port to allow you to directly manage the ftServer system. Use the Virtual Infrastructure (VI) Client to manage the server, but also provide serial access to the system from a management PC. You can provide this access either from a computer that is located near the ftServer system and directly attached by the serial cable, or from a computer that is connected to the ftServer system through a serial port concentrator.

---

# Appendix A

## System Specifications

For system specifications, see:

- [“Pedestal System Specifications” on page A-1](#)
- [“Rack-Mountable System Specifications” on page A-7](#)
- [“AAP86900 and AAP87600 PDU Specifications” on page A-12](#)

### NOTES

---

1. The system temperature and humidity requirements defined in Tables [A-3](#) and [A-4](#) are the **minimum** requirements the site must provide.
2. The temperature and humidity requirements for optional components are provided in the *Stratus ftServer Systems: Peripherals Site Planning Guide (R582)*.

## Pedestal System Specifications

The following figures show front and rear views of the systems.

- [Figure A-1](#) shows the front of a pedestal ftServer 2510 or 4410 system, its bezel pulled forward.
- [Figure A-2](#) shows the rear of a pedestal ftServer 2510 or 4410 system with no VTMs, specifying the locations of the connectors at the back of the system.
- [Figure A-3](#) shows the rear of a pedestal ftServer 2510 or 4410 system that has VTMs, specifying the locations of the connectors at the back of the system.

[Table A-1](#) lists specifications for pedestal ftServer 2510 or 4410 systems.

**Figure A-1. Pedestal ftServer 2510 or 4410 System: Front View**

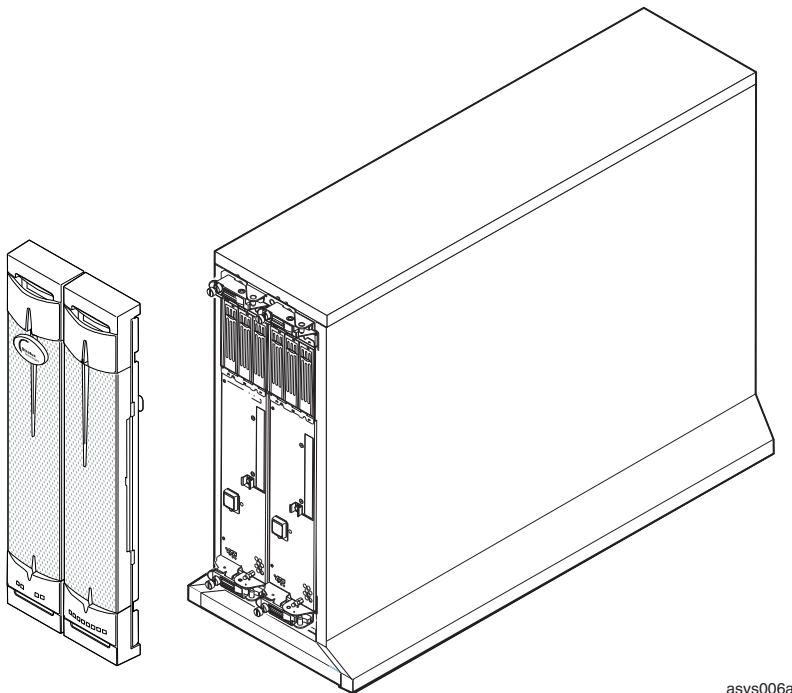

asys006a

Figure A-2. Pedestal ftServer 2510 or 4410 System (No VTMs): Rear View

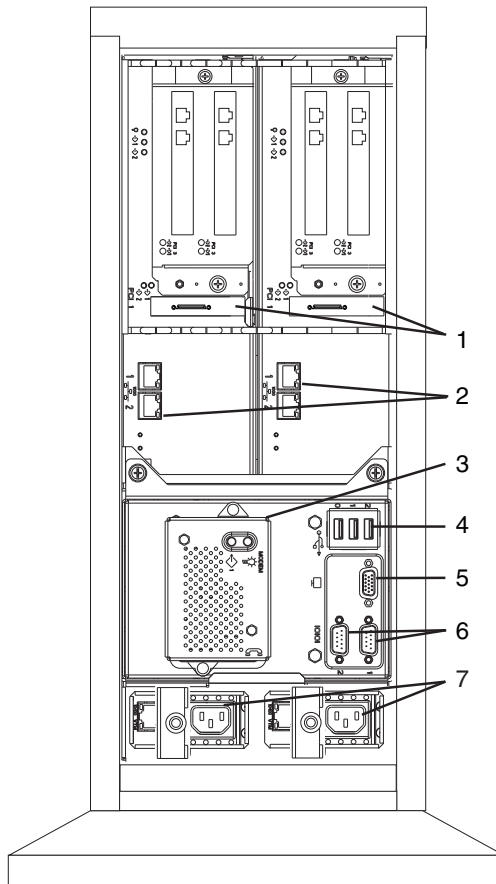

fhsys007a

- 1 Ports on a PCI adapter in slot 1
- 2 System 10/100/1000-Mbps Ethernet ports (4)
- 3 Modem and telephone cord port
- 4 USB ports (3)
- 5 VGA (monitor) port
- 6 Serial (COM) ports (2)
- 7 Power receptacles (2)

Figure A-3. Pedestal ftServer 2510 or 4410 System (With VTMs): Rear View

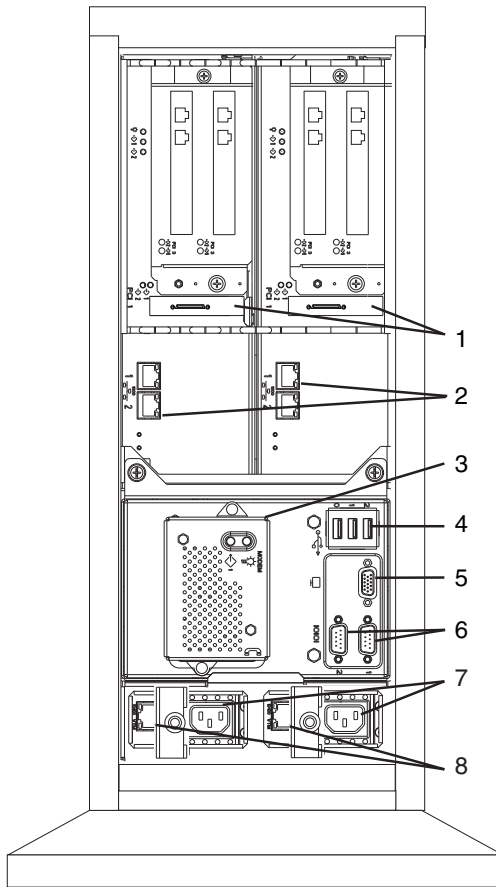

fhsys007b

- 1 Ports on a PCI adapter in slot 1
- 2 System 10/100/1000-Mbps Ethernet ports (4)
- 3 Modem and telephone cord port
- 4 USB ports (3)
- 5 VGA (monitor) port
- 6 Serial (COM) ports (2)
- 7 Power receptacles (2)
- 8 VTM 10/100-Mbps Ethernet port (2)

**Table A-1. Pedestal ftServer 2510 or 4410 System Specifications**

<b>Power</b>	
Input power	650W for each enclosure (1300W total)
Nominal input voltage (AC)	100-127 or 200-240 volts; 50/60 Hz
Protective earth ground current	3.5 mA maximum for each AC power cord
<b>Physical Dimensions of System in a Pedestal Case</b>	
Height	23.25 in. (59.05 cm.)
Width	8.62 in. (21.89 cm); 12.88 in. (32.72 cm)
Depth	31.38 in. (79.71 cm)
Weight, including 6 DIMMS, 4 processors, and 6 disks	Two enclosures: 110 lb (49.9 kg), fully loaded Case: 68 lb (30.84 kg)
<b>Environmental</b>	
Operating temperature	41° F to 95° F (5° C to 35° C) For every 800 ft (243.8m) above 2,000 ft (609.6m), lower the maximum operating temperature (35° C) by 1° C.
Storage temperature	-38° F to 140° F (-40° C to 60° C)
Operating altitude	0 ft to 10,000 ft (0m to 3,048m)
Maximum rate of temperature change during operation	12° C per hour
Relative humidity during operation	20% to 80% (noncondensing)
Relative humidity during storage	8% to 80%
Heat dissipation, each system (both enclosures)	3412 British thermal units (BTUs) per hour
Air cleanliness	Meets ISO 14644-1 class 8 standards
<b>Features</b>	
Processors	ftServer 2510: One Quad-Core Intel® Xeon® 2.0 GHz processor in each CPU-I/O enclosure ftServer 4410: One or two Quad-Core Intel Xeon 2.0 GHz processors in each CPU-I/O enclosure

**Table A-1. Pedestal ftServer 2510 or 4410 System Specifications (Continued)**

Memory	In each CPU-I/O enclosure, six physical, fully-buffered dual inline memory module (FBDIMM) slots utilizing double-data-rate two (DDR2) SDRAM technology
Ports	Two 10/100/1000-Mbps Ethernet ports in each CPU-I/O enclosure  Two AC power connectors, one VGA port, two serial ports, and three USB ports
PCI slots	One of the following: <ul style="list-style-type: none"> <li>• Two full-height-capable PCI-X 64-bit, 100MHz slots, and one low-profile PCI-X, 64-bit, 133MHz slot</li> <li>• Two full-height-capable slots: one PCI-Express<sup>†</sup> x4 (x4 connector) 2.5Gbps slot and one PCI-X 64-bit, 133MHz slot; and one low-profile PCI-X 64-bit, 133 MHz slot</li> </ul>
VTM	An advanced system management module card  When VTMs are installed, a 10/100-Mbps Ethernet port dedicated to the VTM is present for each VTM.  VTMs are optional components on Windows and Linux systems, so the Ethernet ports for them are not functional if VTMs are not present. VTMs are not present on ESX Server systems.
Disk drives	To boot from internal disks, one Serial Attached SCSI (SAS) for boot disks and, optionally, two SAS or Serial ATA (SATA) disk drives for data in each CPU-I/O enclosure  NOTE: Internal disk drives are not supported for use in ESX Server systems.
DVD+/-RW drive	In each CPU-I/O enclosure, one combo drive that reads from and writes to CDs and DVDs

† Accommodates x1 through x8 PCI-Express cards.

## Rack-Mountable System Specifications

The following figures show front and rear views of the systems.

- [Figure A-4](#) shows the front of a rack-mountable ftServer 2510, 4410, or 6210 system, mounted in a rack with its bezel pulled forward.
- [Figure A-5](#) shows the rear of a rack-mountable ftServer 2510, 4410, or 6210 system, specifying the locations of the connectors at the rear of the system.

[Table A-2](#) lists the dimensions of the cabinets supplied by Stratus. [Table A-3](#) lists the specifications for the ftServer 2510, 4410, and 6210 systems. (See [Table A-4](#) for the specifications of the PDU and the *Stratus ftServer Systems: Peripherals Site Planning Guide* (R582) for the specifications of other components.)

**Figure A-4. Rack-Mountable ftServer 2510, 4410, or 6210 System: Front View**

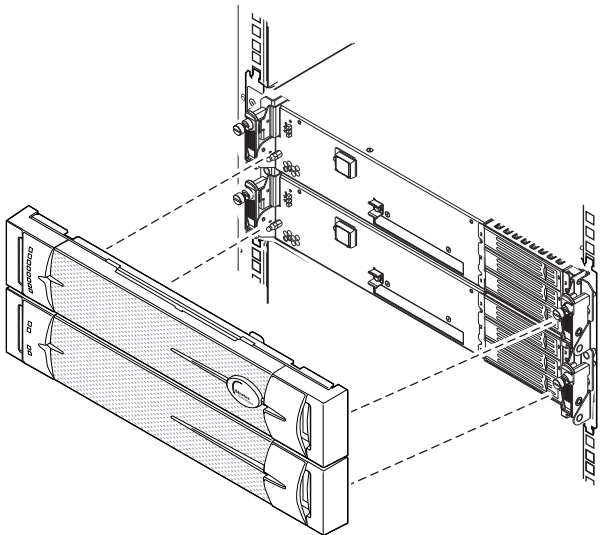

asys009

**Figure A-5. Rack-Mountable ftServer 2510, 4410, or 6210 System (With VTMs): Rear View**

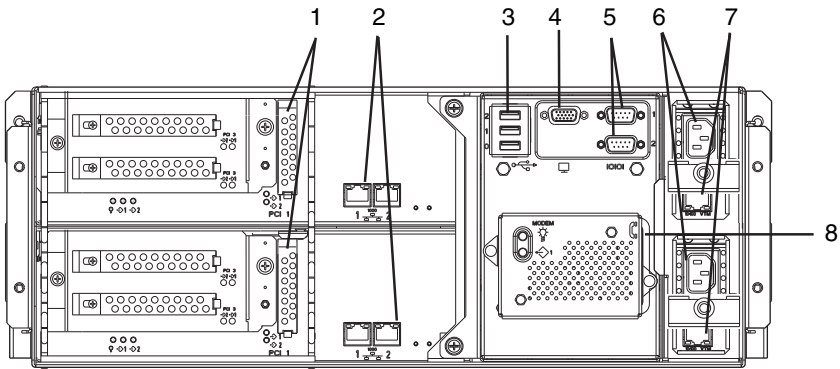

fhsvs034

- 1 PCI slot 1
- 2 System 10/100/1000-Mbps Ethernet ports (4)
- 3 USB ports (3)
- 4 VGA (monitor) port
- 5 Serial (COM) ports (2)
- 6 Power receptacles (2)
- 7 VTM 10/100-Mbps Ethernet ports (2)  
VTMs are optional components on Windows and Linux systems, so the Ethernet ports for them are not functional if VTMs are not present. VTMs are not present on ESX Server systems.
- 8 Modem and telephone cord port

**Table A-2. Cabinet Dimensions**

<b>24U Shipping Container</b>	
Height (including pallet)	56 in. (1.42m)
Width	41 in. (1.04m)
Depth	53 in. (1.35m)
<b>38U Shipping Container</b>	
Height (including pallet)	79.75 in. (2.03m)
Width	41 in. (1.04m)
Depth	53 in. (1.35m)

**Table A-2. Cabinet Dimensions (Continued)**

<b>24U Cabinet</b>	
Height (including casters)	50 in. (1.27m)
Width	27.5 in. (70 cm)
Depth	41 in. (1.04m)
Weight, empty	275 lb (125 kg)
Weight, empty with pallet and shipping container	436 lb (197.8 kg)
Weight capacity	1500 lb (559.9 kg)
<b>38U Cabinet</b>	
Height (including casters)	74 in. (1.9m)
Width	27.5 in. (70 cm)
Depth	41 in. (1.04m)
Weight, empty	344 lb (156 kg)
Weight, empty with pallet and shipping container	512 lb (232.2 kg)
Weight capacity	1500 lb (559.9 kg)

**Table A-3. Rack-Mountable ftServer 2510, 4410, and 6210 System Specifications**

<b>Power</b>	
Input power	650W for each enclosure (1300W total)
Nominal input voltage	100-127 or 200-240 volts; 50/60 Hz
Protective earth ground current	3.5 mA maximum for each AC power cord
<b>Physical Dimensions</b>	
Height	7.0 in. (17.78 cm; 4U)
Width	17.50 in. (44.45 cm)
Depth	30 in. (76.2 cm), excluding screws and bezel
Weight, including 6 DIMMS, 4 processors, and 6 disks	Two enclosures: 110 lb (49.9 kg), fully loaded Rails and shelf unit: 13.8 lb (6.26 kg)

**Table A-3. Rack-Mountable ftServer 2510, 4410, and 6210 System Specifications** (Continued)

<b>Environmental</b>	
Operating temperature	41° F to 95° F (5° C to 35° C) For every 800 ft (243.8 m) above 2000 ft (609.6 m), lower the maximum operating temperature by 1°C.
Storage temperature	-38° F to 140° F (-40° C to 60° C), vented
Operating altitude	0 ft to 10,000 ft (0m to 3,048m)
Maximum rate of temperature change during operation	12° C per hour
Relative humidity during operation	20% to 80% (noncondensing)
Relative humidity during storage	20% to 80%
Heat dissipation, each system (both enclosures)	ftServer 2510 and 4410: 3412 BTUs per hour ftServer 6210: 5118 BTUs per hour
Air cleanliness	Meets ISO 14644-1 class 8 standards
<b>Features</b>	
Processors	ftServer 2510: One Quad-Core Intel Xeon 2.0 GHz processors in each CPU- I/O enclosure  ftServer 4410: One or two Quad-Core Intel Xeon 2.0 GHz processors in each CPU- I/O enclosure  ftServer 6210: Two Quad-Core Intel Xeon 3.0 GHz processors in each CPU- I/O enclosure
Memory	Six physical, fully-buffered (FB) double-data-rate (DDR) inline memory module (DIMM) slots in each CPU- I/O enclosure
Ports	Two 10/100/1000-Mbps Ethernet ports in each CPU- I/O enclosure  Two AC power connectors, one VGA port, two serial ports, and three USB ports

**Table A-3. Rack-Mountable ftServer 2510, 4410, and 6210 System Specifications** (Continued)

PCI slots	<p>One of the following:</p> <ul style="list-style-type: none"> <li>• Two full-height-capable PCI-X 64-bit, 100MHz slots, and one low-profile PCI-X, 64-bit, 133MHz slot</li> <li>• Two full-height-capable slots: one PCI-Express (x4 connector) 2.5Gbps slot and one PCI-X 64-bit, 133MHz slot; and one low-profile PCI-X 64-bit, 133 MHz slot</li> </ul>
VTM	<p>An advanced system management module card</p> <p>When VTMs are installed, a 10/100-Mbps Ethernet port dedicated to the VTM is present for each VTM.</p> <p>VTMs are optional components on Windows and Linux systems, so the Ethernet ports for them are not functional if VTMs are not present. not present on ESX Server systems. VTMs are not present on ESX Server systems.</p>
Disk drives	<p>To boot from internal disks, one Serial Attached SCSI (SAS) disk for boot disks and, optionally, two SAS or Serial ATA (SATA) disk drives for data in each CPU-I/O enclosure.</p> <p>NOTE: Internal disk drives are not supported for use in ESX Server systems.</p>
DVD+/-RW drive	<p>In each CPU-I/O enclosure, one combo drive that reads from and writes to CDs and DVDs.</p>

## AAP86900 and AAP87600 PDU Specifications

A power distribution unit (PDU) optionally supplies power to rack-mounted ftServer systems and optional rack-mountable components. [Figure A-6](#) shows the AAP86900 PDU and [Figure A-7](#) shows the AAP87600 PDU.

**Figure A-6. AAP86900 PDU**

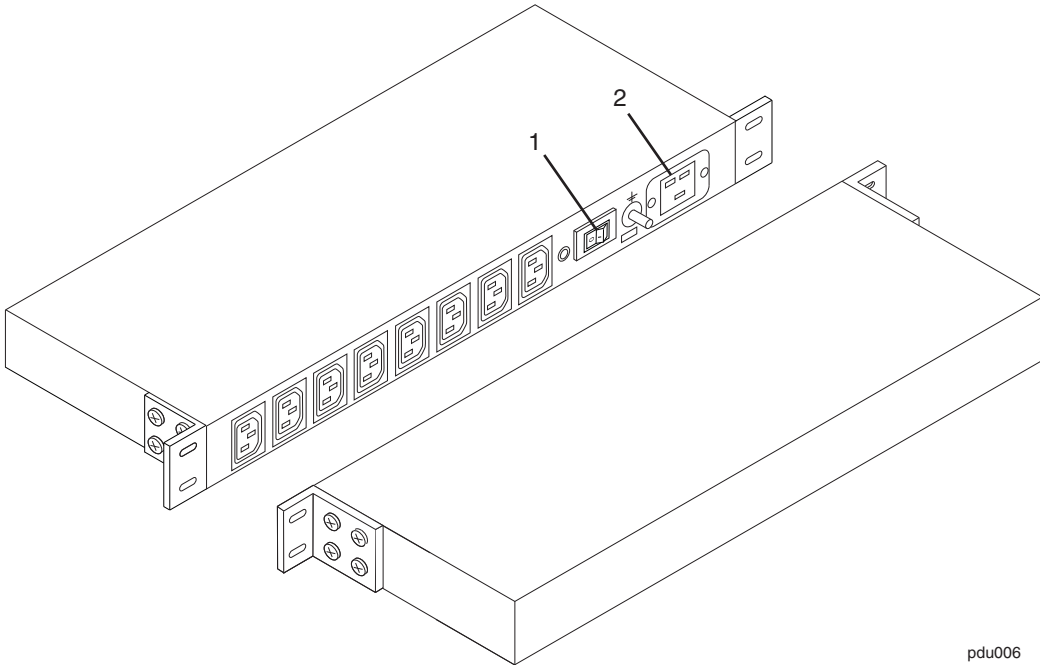

pdu006

- 1 Power switch
- 2 Power receptacle

**Figure A-7. AAP87600 PDU**

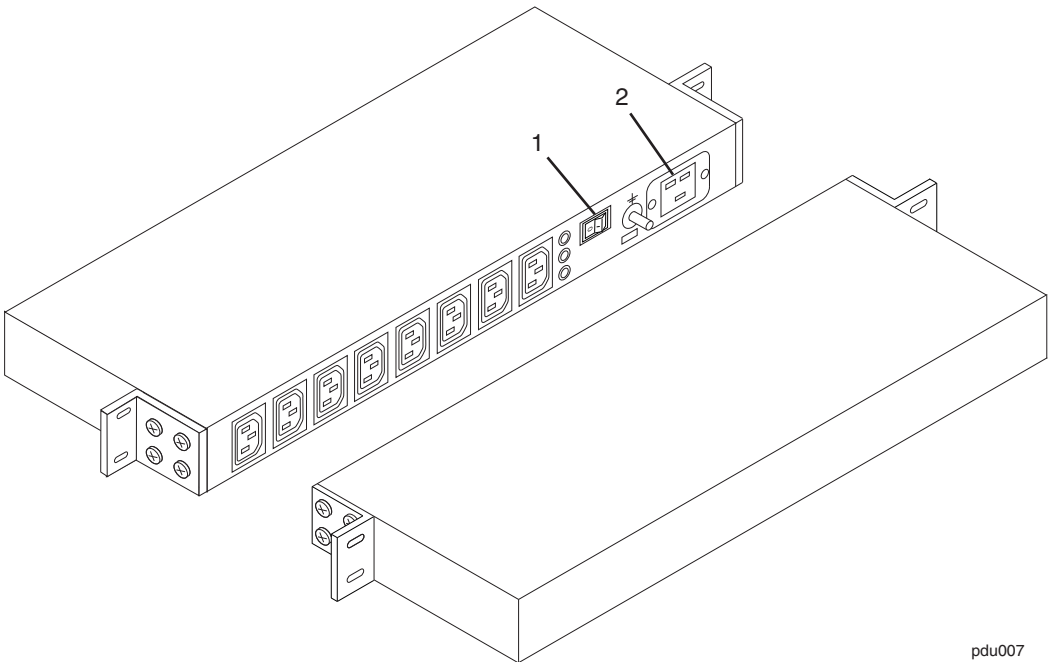

pdu007

- 1 Power switch
- 2 Power receptacle

Table A-4 lists the specifications for the AAP87600 and AAP86900 PDUs.

**Table A-4. AAP87600 and AAP86900 PDU: Specifications**

<b>Power</b>	
Input power	N/A
Nominal input voltage; frequency	200–240 VAC; 50/60 Hz
<b>Physical Dimensions</b>	
Height	1.75 in. (4.45 cm)
Width	19.1 in. (48.51 cm)
Depth	6.75 in. (17.15 cm)
<b>Environmental</b>	
Operating temperature during operation	41° F to 95° F (5° C to 35° C) For every 800 ft (243.8m) above 2000 ft (609.6m), lower the maximum operating temperature (95° F (35° C)) by 1.8° F (1° C).
Maximum rate of temperature change during operation	12° C per hour or 0.2° C per minute
Relative humidity during operation	10% to 80% (noncondensing)
Storage temperature to 40,000 ft (12.2 km)	-38° F to 140° F (-40° C to 60° C)
Relative humidity during storage	5% to 95% (noncondensing)

---

# Appendix B

## Electrical Circuit and Wiring Information

For electrical circuit and wiring information that you need to provide to the contractor and/or facilities personnel responsible for wiring the power at the system installation site, see:

- [“Fault Protection Requirements” on page B-1](#)
- [“Grounding Considerations” on page B-1](#)
- [“Circuit Wiring Diagrams” on page B-2](#)
- [“Electrical Power Connectors” on page B-8](#)

### Fault Protection Requirements

Each enclosure in ftServer systems contains internal fault/overload current protection. However, the system relies on the power distribution system at your site for protection against potential faults in the power cords and the wiring in the system base.

The pair of PDUs in the cabinet uses 20A or less circuit breakers in each power distribution branch that feeds the PDUs.

### Grounding Considerations

The system obtains an earth reference ground through the power cords attached to the system. Similarly, each peripheral device connected to the system obtains ground through its power cord. For each peripheral device, you **must** ensure that a high-integrity safety-ground conductor is installed as part of the wiring system (in accordance with U.S. national electric code NFPA 70 or the equivalent). The international safety standard (EN60950) for electronic data processing (EDP) equipment also requires a ground conductor, but calls it a protective earth (PE) ground.

Depending upon local conditions, ground potentials may differ between the system base and any peripheral devices connected to the system base. All grounds in the system **must** return to the same reference point in the power distribution system, as close as possible to **zero (0) volt potential** relative to earth reference ground. Earth reference ground is typically a metal stake in the ground to which the ground conductors from one or more buildings are attached.

As shown in [Figure B-1](#), a *star ground* is often used to obtain the same earth reference ground. Each earth reference ground, such as the system base ground, is returned separately to a common point where a zero-volt (0V) earth ground exists. The star ground ensures that all equipment is at the same potential and that no noise or safety problems associated with an unpredictable or uncharacterized grounding system will occur.

**Figure B-1. Star Ground Example**

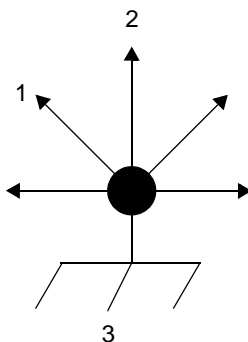

- 1 To monitor
- 2 To ftServer system
- 3 Earth reference ground (0V)

## Circuit Wiring Diagrams

The following circuit wiring diagrams show how the hot, ground, and/or neutral AC signals should be connected to the power input plugs of the system and optional components:

- [Figure B-3](#) illustrates a single-phase 120V AC circuit connection.
- [Figure B-4](#) illustrates a single-phase 240V AC circuit connection.
- [Figure B-5](#) illustrates a split-phase 120/240V AC circuit connection.
- [Figure B-6](#) illustrates a three-phase 208V AC, Y-, or  $\Delta$ -source circuit connection, phase-to-phase.
- [Figure B-7](#) illustrates a three-phase 380V AC, Y-, or  $\Delta$ -source circuit connection, phase-to-neutral.

In the following diagrams, the power inputs for ftServer 2510, 4410, and 6210 systems are labeled X and Y, as shown in [Figure B-2](#), to eliminate any ambiguities in the nomenclature. For single-phase applications, the X input is connected to the L (Line)

*hot* input, and the Y input is connected to the N (Neutral) input. However, for split-phase or three-phase applications, the X and Y inputs are connected to L1, L2, or L3 (separate lines). Therefore, for split-phase or three-phase applications, both X and Y can be electrically hot with respect to the system base (earth reference ground).

Figure B-2 shows the physical locations of the X and Y inputs on the system base.

**Figure B-2. Power Input Labeling**

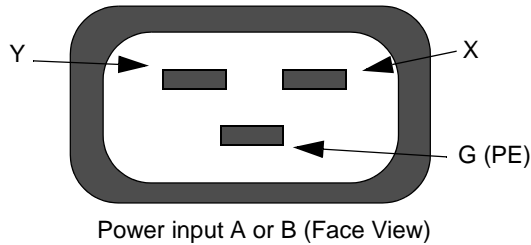

Figure B-3 shows a single-phase 120V AC circuit connection. Note that this application requires a single-pole circuit breaker.

**Figure B-3. Single-Phase 120V AC Circuit Connection**

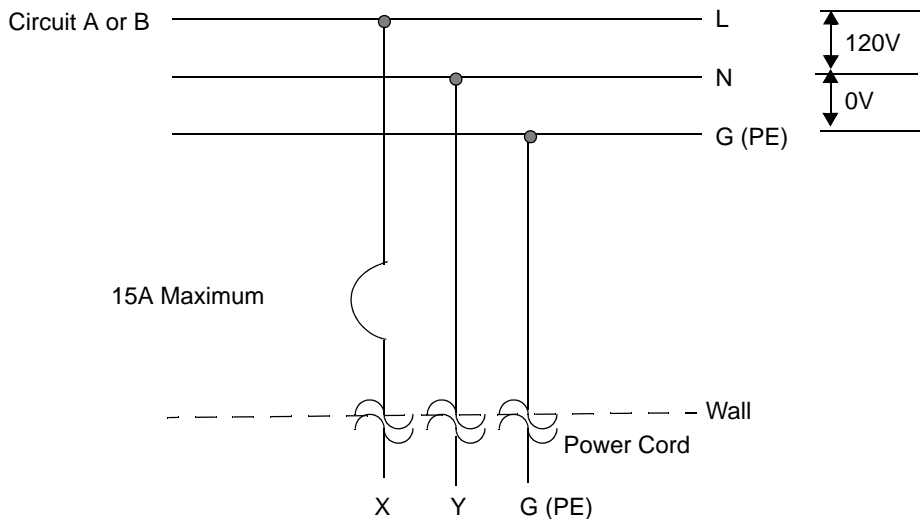

Figure B-4 shows a single-phase 240V AC circuit connection. Note that this application requires a single-pole circuit breaker.

Figure B-4. Single-Phase 240V AC Circuit Connection

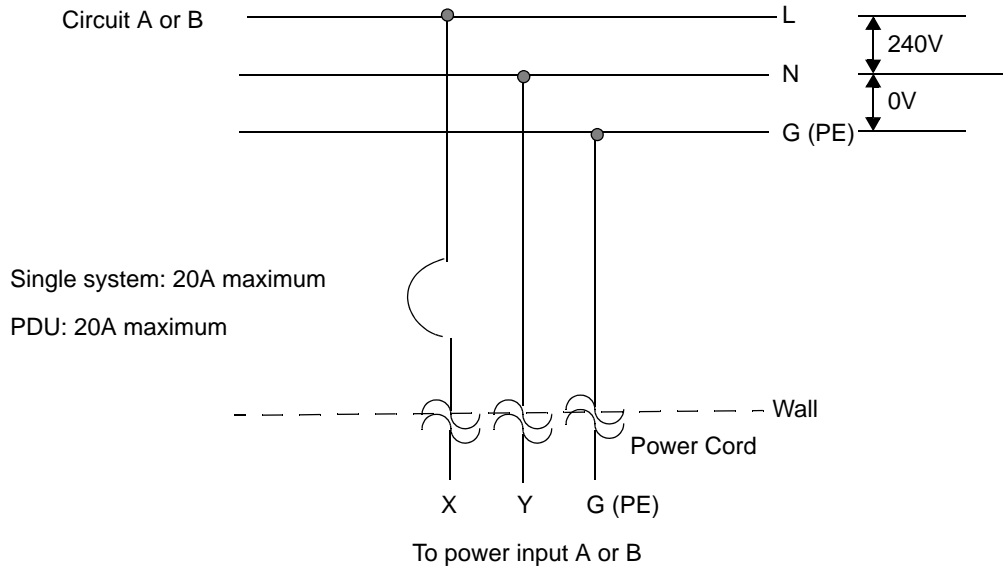

Figure B-5 shows a split-phase 120/240V AC circuit connection. Note that this application requires a double-pole circuit breaker.

**Figure B-5. Split-Phase 120/240 Volts AC Circuit Connection**

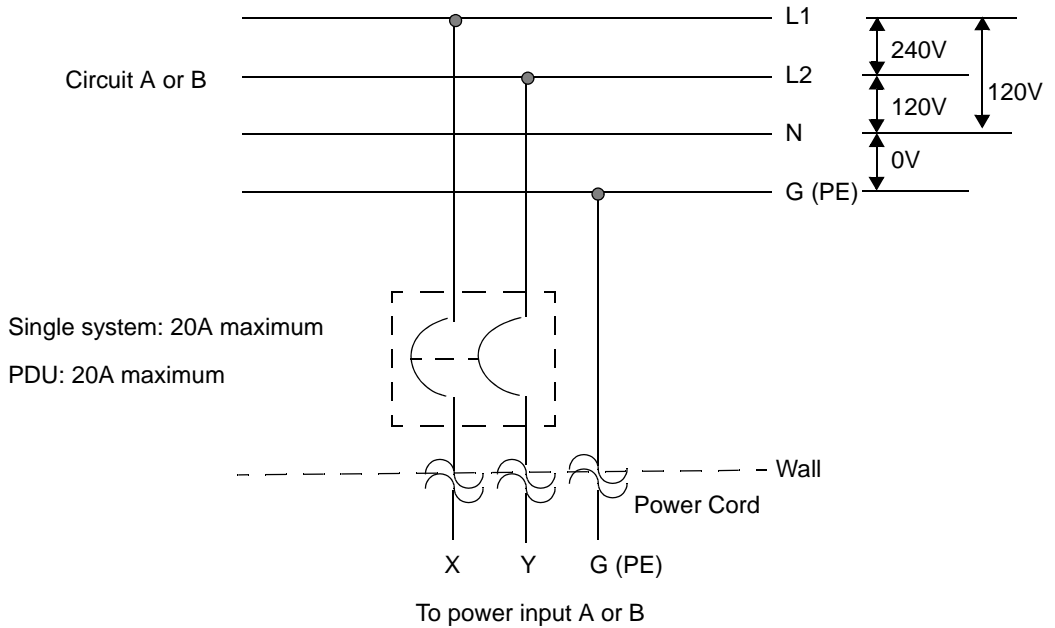

Figure B-6 shows a three-phase 208V AC, Y-, or  $\Delta$ -source circuit connection, which is a phase-to-phase source connection. Note that the X and Y inputs on the system can be connected from L1 and L2, L2 and L3, or L1 and L3. This application requires a double-pole circuit breaker.

**Figure B-6. Three-Phase 208V AC, Y-, or D-Source Circuit Connection, Phase-to-Phase**

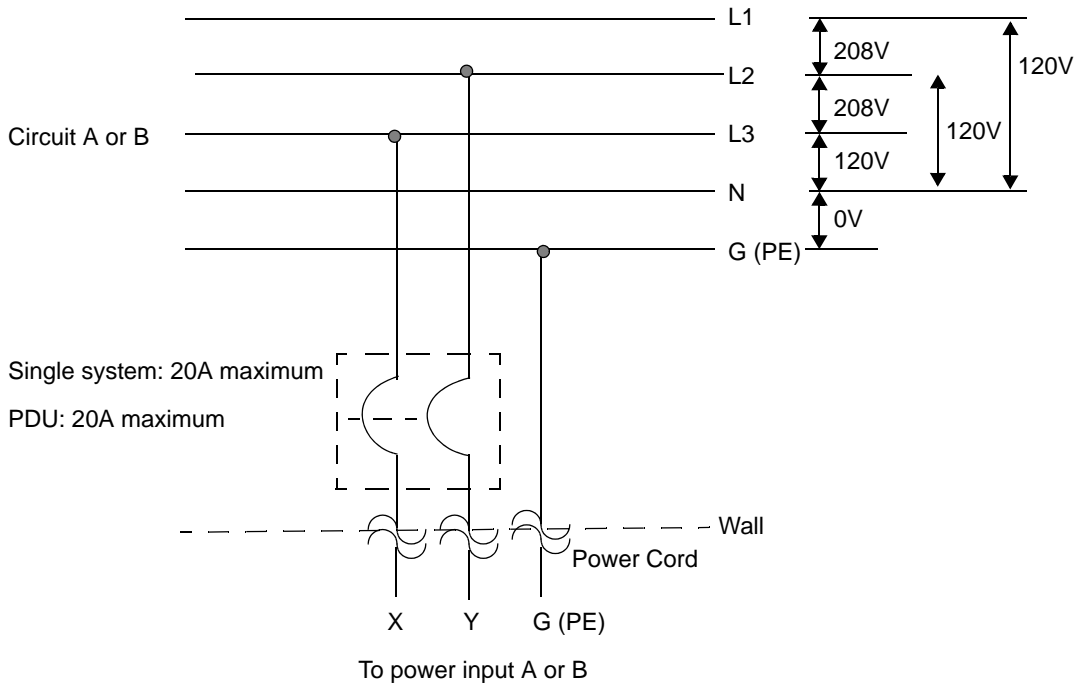
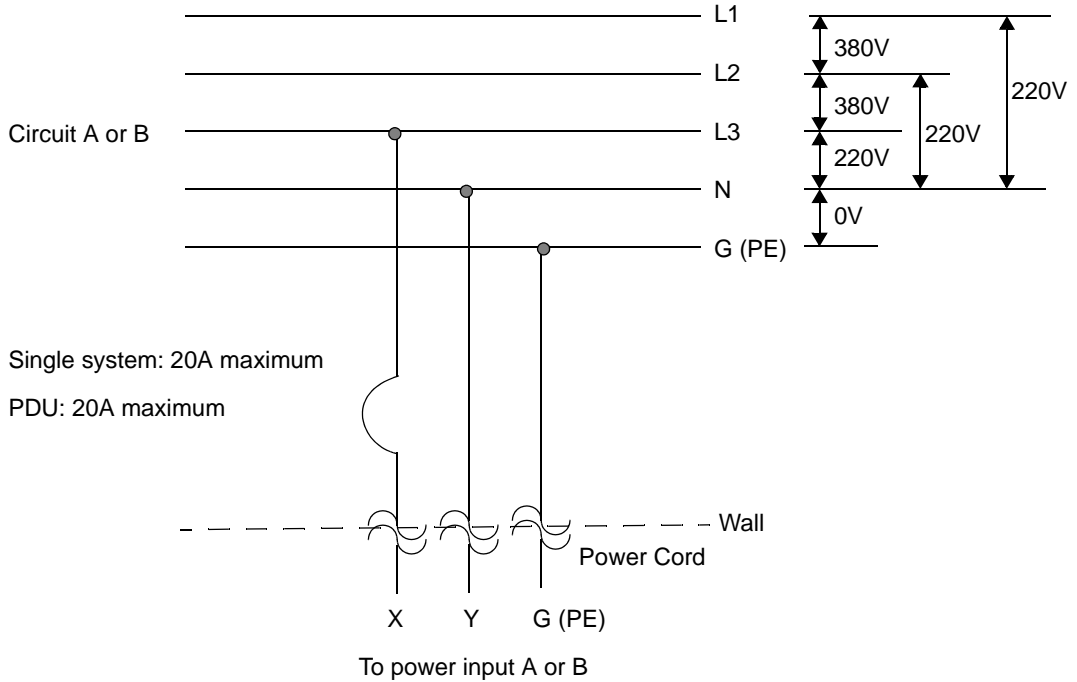

Figure B-7 shows a three-phase 380V AC, Y-, or  $\Delta$ -source circuit connection, which is a phase-to-neutral source connection. Note that the system's X input can be connected to L1, L2, or L3. This application requires a single-pole circuit breaker.

**Figure B-7. Three-Phase 380V AC, Y-, or  $\Delta$ -Source Circuit Connection, Phase-to-Neutral**



## Electrical Power Connectors

Table B-1 describes the connectors required by the AC power cords that Stratus supplies with ftServer systems and optional devices.

**Table B-1. Connectors for AC Power Outlets**

Connector	Configuration	Rating	Description
NEMA L6-20		20A, 250 volts AC	2-pole, 3-wire
NEMA 5-15		15A, 125 volts AC	2-pole, 3-wire
NEMA L6-30		30A, 250 volts AC	2-pole, 3-wire
CEE (7) VII		20A, 250 volts AC	2-pole, 3-wire
IEC 60309 (formerly IEC 309)		16-20A, 250 volts AC	2-pole, 3-wire

Table B-1. Connectors for AC Power Outlets (Continued)

Connector	Configuration	Rating	Description
SABS 164-1:1992		16A, 250 volts AC	2-pole, 3-wire
BS 1363/A		13A, 250 volts AC	2-pole, 3-wire
SEV 1011-S24507		10A, 250 volts AC	2-pole, 3-wire
SAA/3/15 AS/NZS 3112-1993		15A, 250 volts AC	2-pole, 3-wire
GB1002-1996		10A, 250 volts AC	2 pole, 3-wire

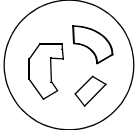
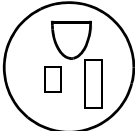
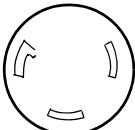
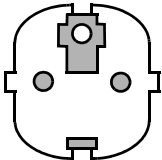
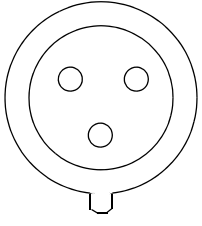
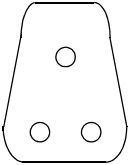
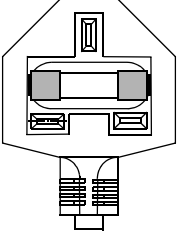
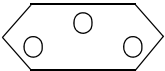
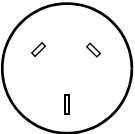
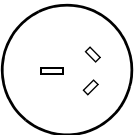

---

## Appendix C

# Standards Compliance

For compliance information, see the following:

- [“Electronic Interference, Immunity, Safety, and Noise Level Standards Compliance” on page C-1](#)
- [“Toxic and Hazardous Substances and Elements Disclosure” on page C-4](#)

## Electronic Interference, Immunity, Safety, and Noise Level Standards Compliance

All ftServer systems comply with the electromagnetic interference (EMI), immunity, safety, and noise regulations listed in [Table C-1](#). All necessary agency labels are on the system.

### NOTES \_\_\_\_\_

1. This system must be configured with the components listed and described in the product configuration specifications. Deviations from this list of components will void agency certification.
2. You must install all wiring, including power and communications cables, in compliance with local and national electrical code (in the United States, national electrical code NFPA 70). In addition, you must use shielded communications cables to remain in compliance with Federal Communications Commission (FCC) and other international Electromagnetic compatibility (EMC) regulations.
3. All EMC emissions compliance tests are performed at a third-party certified test laboratory.

This equipment has been tested and found to comply with the limits for a Class A digital device, pursuant to part 15 of the FCC Rules. These limits are designed to provide reasonable protection against harmful interference when the equipment is operated in a commercial environment. This equipment generates, uses, and can radiate radio frequency energy and, if not installed and used in accordance with the instruction

manual, may cause harmful interference to radio communications. Operation of this equipment in a residential area is likely to cause harmful interference, in which case the user will be required to correct the interference at his own expense.

**Table C-1. Compliance Standards for ftServer 2510, 4410, and 6210 Systems**

Standard	Title	Country
EN 55022:1998, A1: 2000, A2: 2003 Class A	Limits and methods of measurement of radio interference characteristics of Information Technology Equipment	European Union
EN 55024:1998, A1: 2001, A2: 2003 Class A	Information Technology Equipment - Immunity characteristics - Limits and methods of measurement	European Union
EN 61000-3-2: 2006	Electromagnetic compatibility (EMC) – Part 3-2: Limits – Limits for harmonic current emissions (equipment input current <= 16 A per phase)	European Union
EN 61000-3-3: 1995, A1: 2001, A2:2005	Electromagnetic compatibility (EMC) – Part 3-3: Limits – Limits of voltage changes, voltage fluctuations and flicker in public low-voltage supply systems (equipment input current <= 16 A per phase)	European Union
EN 60950-1:2001	Safety of Information Technology Equipment	European Union
CB SCHEME IEC 60950-1:2001 and EN 60950-1:2001	Safety of Information Technology Equipment	
UL 60950-1 1st Ed, 2006-07-07, CSA C22.2 No. 60950-1-03, 1st Ed 2006-07	Safety of Information Technology Equipment	Certified to US and Canada standards
CISP22: 2006 Class A	Information Technology Equipment: Radio disturbance characteristics	European Union
FCC CFR47, Part 15: 8/14/2006, Class A	Code of Federal Regulations, Radio Frequency Devices	North America
AS/NZS CISPR 22:2006, Class A	Information Technology Equipment - Radio Disturbance Characteristics - Limits and Methods of Measurement	Australia and New Zealand
ICES-003: issue 4, 2/2004, Class A	Electronic Emissions from Data Processing Equipment and Electronic Office Machines	Canada

**Table C-1. Compliance Standards for ftServer 2510, 4410, and 6210 Systems (Continued)**

Standard	Title	Country
STQC–Safety Certification (S-Mark) Scheme IEC 60950-1:2001	Safety of Information Technology Equipment	India
VCCI V-3 (2006.04) Class, Class A	Voluntary Control Council for Interference by Information Technology Equipment	Japan
Logis NOM-019-SCF-1998 (Highly Specialized Equipment)	Information Technology Equipment	Mexico
GOST R MEK 60950-1-2005, GOST R 51318.22-99, GOST R 51318.24-99, GOST R 51317.3.2-99, GOST R 51317.3.3-99, GOST R 26329-84	Information Technology Equipment	Russia
RSA CISP22: 2006 Class A	Information technology equipment - Radio disturbance characteristics	South Africa
RSA SABS IEC 60950	Safety of Information Technology Equipment	South Africa
RRL 2008-39 (2008.5.19), 2008-3 (2008-5-21), 2008-38 (2008.5.19), 2008-4 (2008-4 (2008.5.21), Annex 4 of the No. 2008-7, 2008-7 (2008.5.23)	Information and Communication Equipment–EMC, Safety, Telecom	South Korea
BSMI, CNS13438 (95) CNS14336 (94), Class A	Information technology equipment - Radio disturbance characteristics	Taiwan

**VCCI Note**

この装置は、情報処理装置等電波障害自主規制協議会（VCCI）の基準に基づくクラスA情報技術装置です。この装置を家庭環境で使用すると電波妨害を引き起こすことがあります。この場合には使用者が適切な対策を講ずるよう要求されることがあります。

**BSMI Note**

警告使用者  
這是甲類的資訊產品、在居住的環境中使用時、可能會造成射頻干擾、在這種情況下、使用者會被要求採取某些適當適對策

## Toxic and Hazardous Substances and Elements Disclosure

ftServer 2510, 4410, and 6210 systems are compliant with the European Union's Restriction of Hazardous Substances Directive (RoHS) based upon the exception for lead used in servers.



**WARNING** \_\_\_\_\_

**The lithium battery contains perchlorate material.  
Special handling may apply. See  
[www.dtsc.ca.gov/hazardouswaste/perchlorate](http://www.dtsc.ca.gov/hazardouswaste/perchlorate).**

---

# Index

## A

- AC power service requirements, 2-2
- ActiveService Network (ASN). *See* ASN
- APC UPS, 2-14
  - Network Management Card EX, 2-11
  - PowerChute Network Shutdown, 2-11
  - qualified models, 2-10
  - qualified Symmetra models, 2-10
- AS/NZS 3112-1993 connector, B-9
- A-side power source, 2-1
- ASN, site planning, 1-3, 3-3, 4-8

## B

- BS 1363/A connector, B-9
- B-side power source, 2-1

## C

- cabinets
  - configuration planning, 5-1, 5-5
  - requirements, 6-1
  - specifications, A-8
- cables
  - Ethernet network, 4-6
  - Fibre Channel, 4-3
  - null modem
    - management PC, 4-8
  - planning for, 3-3, 4-1
  - SCSI, 4-2
  - serial
    - management PC, 4-8
  - telephone, 3-3
- CAC, getting assistance, 1-2
- CEE (7) VII connector, B-8
- checklist for site planning, 1-2
- circuit, electrical
  - planning information, B-1
  - wiring diagrams, B-2
- communications cables
  - planning for, 4-1

- compliance, standards, C-1
- connectors, electrical, B-8
- CPP
  - UPS, 2-14
- current requirements, from PDU, 5-2
- Customer Assistance Center. *See* CAC

## D

- dust contamination, 3-1

## E

- earth reference ground, B-1
- electrical connectors, B-8
- electrical grounding, B-1
- electrical power planning, 2-1
- electrical wiring, B-1
- EMC storage systems, 1-5, 4-3
- environmental requirements
  - maximum rate of temperature change, A-5, A-10
  - operating humidity, A-5, A-10
  - operating temperature, A-5
  - storage humidity, A-5, A-10
- Ethernet
  - network cables, 4-6

## F

- fault-tolerant systems, site planning, 1-3
- Fibre Channel cables, 4-3
- Fibre Channel switches, 1-5
  - electrical requirements, 2-3
- Fibre-Channel connections, 4-3
- ftGateway, site planning information, 4-9
- ftScalable Storage systems, 1-5
  - Ethernet cables, 4-7
  - Ethernet connections, 4-6
  - Fibre Channel connections, 4-3
  - management PC, 4-6

## G

GB1002-1996 connector, B-9  
grounding the system, 2-17, 6-2, B-1

## H

hubs, network, 3-3

## I

IEC 60309 connector, B-8  
ISO 14644-1 class 8 standards, 3-1

## J

jacks, Ethernet, 3-3

## L

LCD monitor units  
power cords, 2-15

## M

management PC  
for ESX Server systems, 3-2, 4-8, 6-4  
for ftScalable Storage systems, 4-6, 4-7  
for VTMs, 4-5  
monitors  
power cords, 2-15  
requirements, 6-4

## N

NEMA 5-15 connector, B-8  
NEMA L6-20 connector, B-8  
NEMA L6-30 connector, B-8  
network (Ethernet) cables, 4-6  
network management card, UPS, 2-11  
null modem cables  
management PC, 4-8

## O

optical Fibre-Channel connections, 4-3

## P

PDU  
configuration planning, 5-1  
power (*jumper*) cables, 2-17

power cords, 2-16  
site planning, A-12  
specifications, A-14  
usage calculation  
sample, 5-4  
worksheets, 5-4

## power (AC)

cords  
LCD monitor units, 2-15  
monitors, 2-15  
storage enclosures, 2-15  
systems, 2-15  
tape-drive enclosures, 2-15  
electrical requirements, 2-2  
PDU connections, illustrated, 2-12  
service requirements, 2-2, 2-4, 2-5  
A-side, 2-4, 2-5  
B-side, 2-4, 2-5  
sources, 2-1  
direct, 2-6  
UPS, 2-11, 2-13  
system connections, illustrated, 2-6, 2-7  
UPS connections, illustrated, 2-13, 2-14  
wall outlets, 2-4, 3-3

PowerChute Network Shutdown, 2-11  
protective earth ground, B-1

## R

racks  
configuration planning, 5-1, 5-5  
requirements, 6-1  
removing power, 1-11  
room requirements, 3-1

## S

SAA/3/15 AS/NZS 3112-1993 connector, B-9  
SABS 164-1:1992 connector, B-9  
safety  
notices, 1-11  
SCSI cables, 4-2  
SCSI connections to tape drives, 4-2  
serial cables, 4-8  
service requirements, AC-power, 2-2  
SEV 1011-S24507 connector, B-9  
single-phase circuit connections  
120 V AC, B-3  
240 V AC, B-4

- site planning
  - checklist, 1-2
  - overview, 1-1
- space planning, 3-1
  - cables, 3-3
  - future expansion, 3-2
  - room requirements, 3-1
- specifications
  - AC power, 2-2
  - cabinet, A-8
  - PDUs, A-14
  - pedestal system, A-1
  - rack-mountable system, A-7
- split-phase circuit connections
  - 120–240 V AC, B-5
- standards compliance, C-1
- star ground, B-2
- Stratus Customer Assistance Center. *See* CAC
- switches
  - Ethernet
    - cable planning, 3-3, 4-6, 4-7
  - Fibre Channel, 1-5
    - cable planning, 4-4
  - power
    - PDU, A-13
    - site network, 3-3
- system power cords, 2-15
- system specifications
  - pedestal systems, A-1, A-5
  - rack-mounted systems, A-7, A-9

## T

- tape-drive enclosures
  - power cords, 2-15
  - SCSI cables, 4-2
- technical support. *See* CAC
- telephone lines, 4-8
  - for ASN modem assembly, 1-4, 4-8
  - for support calls, 4-8
- telephones
  - for support calls, 1-4
- terminal emulator, 6-4
- three-phase circuit connections
  - 208 V AC, B-6
  - 380 V AC, B-7

## U

- uninterruptible power supply (UPS). *See* UPS
- UPS, 2-14
  - network communication hardware, 2-11
  - network communication software, 2-11
  - network management card, 2-11
  - PDU connections, 2-11
  - pedestal system connections, 2-14
  - rack system connections, 2-13

## V

- Virtual Technician Modules. *See* VTMs
- VTMs, site planning, 1-3

## W

- wiring, electrical, B-1

